

# Environmental Assessment of a Multifunctional Process Coupling Anaerobic Digestion and Pyrolysis

Fanny Caiardi<sup>a,\*</sup>, Jean-Pierre Belaud<sup>b</sup>, Claire Vialle<sup>a</sup>, Florian Monlau<sup>c</sup>, Saida Tayibi<sup>d</sup>  
Abdellatif Barakat<sup>e</sup>, Abdallah Oukarroum<sup>d</sup>, Youssef Zeroual<sup>f</sup>, Caroline Sablayrolles<sup>a</sup>

<sup>a</sup> Laboratoire de Chimie Agro-industrielle (LCA), Université de Toulouse, INRAE, Toulouse, France

<sup>b</sup> Laboratoire de Génie Chimique (LGC), Université de Toulouse, CNRS, Toulouse, France

<sup>c</sup> APESA, Pôle valorisation, Cap Ecologia, 64 230 Lescar, France

<sup>d</sup> Mohammed VI Polytechnic University (UM6P), Ben Guerir, Morocco

<sup>e</sup> INRAE, Agro Institut, IATE, Montpellier University, 34 060 Montpellier, France

<sup>f</sup> Situation Innovation, OCP Group, Complexe industriel Jorf Lasfar, El Jadida, Morocco

[fanny.caiardi@toulouse-inp.fr](mailto:fanny.caiardi@toulouse-inp.fr)

Anaerobic digestion (AD) is a waste treatment technology based on organic matter degradation by microorganisms in the absence of oxygen. This process generates two valuable products, biogas and digestate. While biogas is recognized and exploited for its energy potential, digestate could be an interesting fertilizer thanks to its rich-nutrient composition. However, implementation of AD still raises concerns about energy transportation, consequences of digestate spreading and poor conversion to carbon during digestion. To overcome the issues linked to AD, to integrate anaerobic digestion with the pyrolysis of digestate is an innovative path. This study aims to analyze sustainability of a multifunctional process coupling anaerobic digestion and pyrolysis. The process is applied to the treatment of sewage sludge and quinoa residue in co-digestion. To evaluate environmental impacts, life cycle assessment (LCA) is realized from a cradle-to-gate perspective, using SimaPro software (V8.5.2) and Environmental Footprint EF 3.0 method. Results underline that the main contributor to environmental impacts is the treatment of bio-oil, a pyrolysis product, while other impacts could be counterbalanced thanks to energy production.

## 1. Introduction

A global transition is occurring around the world to move from a fossil-based economy to a new model more environmentally and socially durable. The production of food and energy to fulfil people's basic needs will not decrease anytime soon, but the environmental and societal impacts of these productions must be reduced to leave future generations a "habitable" world. Scientists, researchers, industrials and politicians have to find and develop projects based on global approach integrating sustainable development and circular economy. The valorisation of waste and agricultural by-product is an opportunity to develop industrial ecology (Belaud et al., 2019). Anaerobic digestion is a waste treatment technology that appears to be an essential response to avoid the use of non-renewables resources while producing energy and fertilizer products (Escudie and Cresson, 2017). This technology is based on the degradation of organic matter by microorganisms in the absence of oxygen, conducting to the formation of biogas, a gas mixture saturated with water, composed mainly of methane (CH<sub>4</sub>) and carbon dioxide (CO<sub>2</sub>) and of digestate, a nutrient-rich co-product. Biogas can be used to produce heat and electricity by cogeneration, to produce biofuel or to be injected into the natural gas network after purification. As for digestate, it is generally separated into liquid and solid phases and then spread on agricultural land.

Although AD has greatly developed in the past decades, its implementation still presents several drawbacks. First, some authors underlined a poor conversion to carbon during digestion because microorganisms struggle

to degrade some biomass components (Pecchi and Baratieri, (2019)). They also highlighted that the digestate is often of insufficient quality, due to the low retention capacity of its nutrients: thus, leaching into groundwater can occur (and pollute the water) and gases can be emitted into the atmosphere (CO<sub>2</sub> and nitrogen compounds). Lastly, there is a significant heat loss from biogas cogeneration, because digesters are mostly far from habitations and the heat produced cannot be transported (Monlau et al., 2015). The knowledge of these drawbacks has led to research into improvements of anaerobic digestion process. One possibility is to treat the solid digestate by a pyrolysis process. The latter would increase the efficiency, profitability and durability of the system, by enhancing the energy potential of residual organic substances which are difficult to biodegrade, recovering the heat from biogas cogeneration to dry digestate before pyrolysis, and resulting in a product (biochar) with better characteristics than digestate for the protection of the environment (Monlau et al., 2016, 2015). Pyrolysis is a thermochemical process that occurs in an inert atmosphere, in which organic matter is decomposed under the influence of heat (between 350 °C and 650 °C). This process results in three products: a combustible gas mixture called syngas, a liquid fraction that can be separated into an oily phase called bio-oil and an aqueous phase, and a solid carbon-rich material called biochar. Biochar is of particular interest as it is supposed to improve soil quality and to increase crop yield (Cao and Pawłowski, 2013). Hossain et al. (2010) add that biochar potential would be enhanced if combined with a fertilizer. The integration of anaerobic digestion and pyrolysis is at the core of this paper. The objective is to analyze sustainability of this multifunctional process that is dedicated to the treatment of sewage sludge and quinoa residue in co-digestion. The paper provides first answers to the question: is it relevant and worth to develop such a multifunctional process and associated technologies from an environmental point of view? To evaluate environmental impacts, life cycle assessment (LCA) is selected. This method assesses the impacts associated with all the stages of the life-cycle of a product, process or system, from raw material extraction to final disposal.

## 2. Description of the system

This study aims at evaluating environmental durability of an innovative biorefinery process located in Morocco. The system under evaluation is a process coupling anaerobic digestion with pyrolysis and is dedicated to the treatment of sewage sludge and quinoa residue in co-digestion. Sludge comes from wastewater treatment plant (WWTP) and are centrifuged secondary sludge. Quinoa residue are made of quinoa stalks that are left on land after harvesting, and which undergo a pretreatment step before entering anaerobic digestion, consisting of grinding to reduce stalks in grains. No environmental impacts are allocated to sludge and quinoa, as they are considered as waste.

Both sludge and quinoa residue are blended with water before getting into the digester. AD technologies can be classified depending on the characteristics of the biomass and the stability of the reaction mixture. As the biomass entering the system has a dry matter content of less than 10 %, we are studying wet anaerobic digestion. The introduction of organic matter is continuous and we assume that the reactor is infinitely mixed. The process is mesophilic (temperature 39 °C) with a hydraulic retention time (HRT) of 45 days.

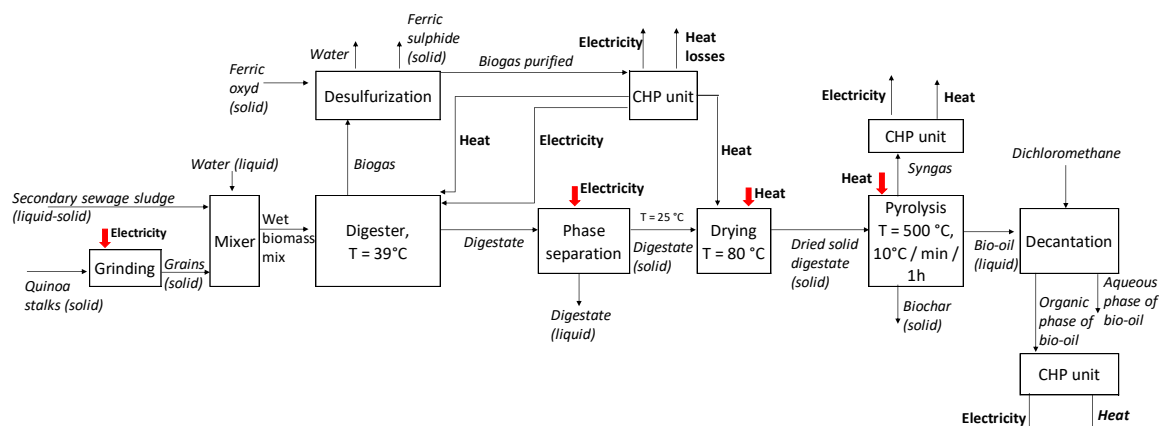

Figure 1 – Process flow diagram

Biogas produced contains hydrogen sulfide H<sub>2</sub>S and needs to be desulfurized before cogeneration. Digestate is separated into two phases in a mechanical press, and the solid phase is dried to be suitable for pyrolysis. As for AD, pyrolysis technologies are also classified according to process parameters. In this study, heat rate is

equal to 10 °C/ min, which is characteristic of slow pyrolysis. Residence time is of one hour, and the maximal temperature is 500 °C. Bio-oil undergoes decantation using dichloromethane to obtain organic and aqueous phases. Syngas and organic bio-oil are converted through CHP (Combined Heat and Power) units for electricity and heat production. Biochar is spread on land along with liquid digestate to improve efficiency. The overall process is presented in Figure 1.

### 3. Materials and methods

In this study, LCA is chosen to evaluate environmental impacts of the process integrating anaerobic digestion and pyrolysis, from a cradle-to-gate perspective. The LCA method is standardized by ISO 14040 and 14044 and is synthesized in four steps: (1) Goal and Scope Definition; (2) Life cycle Inventory (LCI); (3) Life cycle Impact assessment (LCIA); (4) Results and Interpretation. The following subsections relate the realization of these four stages.

#### 3.1 Goal and scope definition

In this first step of LCA, the system to be studied is first defined (boundaries, functions and the related functional unit) as are the scenarios assessed and assumptions made.

The system under evaluation is a multifunctional process coupling anaerobic digestion with pyrolysis, which is dedicated to the treatment of sewage sludge and quinoa residue in co-digestion. Thus, the main function of the system is waste management, while energy and fertilizer production are secondary functions. Subsequently, the functional unit is the treatment of 1 ton of dry matter biomass.

The system boundaries of the system are illustrated in Figure 1. Among the products of the process, biogas, syngas and organic bio-oil are burned to produce heat and electricity in a CHP system. A part of the energy is reused in the system itself, while the overage is sold. The substitution effects of the recovered heat and electricity are evaluated in reference to natural gas and local grid electricity respectively. As for biochar and liquid digestate, they are spread on land because of their fertilizing properties. However, the benefits of biochar and digestate spreading are not taken into account in this study. Similarly, the aqueous phase of bio-oil could be used as a bio-fungicide, but no additional process is avoided by this.

#### 3.2 Life cycle inventory

Within the life cycle inventory (LCI) step, data concerning raw material, energy and emissions used by each process are collected. The quality of the data used is crucial, as it determines the quality and validity of the entire LCA.

Most of the data is obtained thanks to pilot scale experiments performed by APESA (Tayibi et al., 2021), but as it is scarce to collect system-specific data for all the processes included, the LCI database Ecoinvent v3.4 is used to describe the background system processes.

Concerning the water added in the digester, we assumed that it is harvested from rainwater.

As for biogas desulphurization, several methods exist, they can be distinguished into biotechnological and physical-chemicals ones. H<sub>2</sub>S removal can be realized either inside the digester or during a subsequent process. Existing methods occurring in the digester include air/oxygen dosing to the digester or adding iron chloride into the digester. As for conventional post-digestion methods, they include adsorption desulphurization (e.g. metal oxides and zeolite), biological desulphurization, and chemical scrubbing (Andriani et al., 2020). In this study, the adsorption using iron oxide is chosen. This process consists on pumping gas through a reaction bed made of rust steel wool, impregnated wood chips or pellet. Hydrogen sulfide reacts with iron oxide according to Eq (1), to form iron sulphide and water.



This method, known as “iron sponge” process, is one of the oldest desulphurization method and is recognized to be simple and effective. However, it has high operating costs and generate waste materials that must be treated. The regeneration of iron oxide is possible by adding oxygen to iron sulphide according to Eq (2). However, this reaction is highly exothermic and must be carefully controlled to avoid any inhibition risks. In this study, the regeneration step is considered not to be done on-site (Bailon Allegue and Hinge, 2014), and the iron sulphide is considered as an hazardous waste.

Bio-oil is separated into two phases: an organic and an aqueous phases obtained by decantation using dichloromethane as organic solvent. Then the solvent is evaporated using a rotatory evaporator and it is assumed that 80 % of dichloromethane is then recycled.

### 3.3 Life cycle impact assessment

After collecting data, the third step, called life cycle impact assessment (LCIA), consists of estimating environmental impacts of the system by relating the inventory flows in the LCI to the respective environmental impacts. The LCIA is done using SimaPro software (V8.5.2) and EF 3.0 method. This method proposes 16 impact categories: climate change (CC), ozone depletion (OD), ionizing radiation (IR), photochemical ozone formation (POF), particulate matter (PM), human toxicity non cancer (HTNC), human toxicity cancer (HTC), acidification (AD), eutrophication, freshwater (EPF), eutrophication, marine (EPM), eutrophication, terrestrial (EPT), ecotoxicity, freshwater (EF), land use (LU), water use (WU), resource use, fossils (RUF) and resource use, mineral and metals (RUMM). According to the European Commission (European Commission, December 2017), not all categories have the same robustness, ranging from I to III. The results for each impact category are presented with the robustness indicator in Table 1.

### 3.4 Results and interpretations

The LCIA results of the process are presented in Table 1.

*Table 1: Results of the environmental impacts generated by the treatment of 1 ton of dry matter biomass by AD-pyrolysis coupling.*

Impact category	Unit	Value	Robustness indicator
Climate change	kg CO <sub>2</sub> eq	244	I
Ozone depletion	kg CFC-11 eq	1.31x10 <sup>-2</sup>	I
Ionising radiation	kBq U235 eq	-4.75	II
Photochemical ozone formation	kg NMVOC eq	2.09	II
Particulate matter	disease inc.	1.03x10 <sup>-4</sup>	I
Human toxicity, non cancer	CTUh	1.74x10 <sup>-5</sup>	III
Human toxicity, cancer	CTUh	1.66x10 <sup>-7</sup>	III
Acidification	molc H+ eq	1.48	II
Eutrophication, freshwater	kg P eq	-3.01x10 <sup>-2</sup>	II
Eutrophication, marine	kg N eq	7.12x10 <sup>-1</sup>	II
Eutrophication, terrestrial	mol N eq	7.67	II
Ecotoxicity, freshwater	CTUe	1.02x10 <sup>4</sup>	III
Land use	Pt	-958	III
Water use	m <sup>3</sup> depriv.	77.4	III
Resource use, fossils	MJ	856	III
Resource use, minerals and metals	kg Sb eq	-7.69x10 <sup>-4</sup>	III

Except for the ionizing radiation, eutrophication (freshwater), land use and resource use (minerals and metals) impacts, which show emissions mitigations, the other impacts have positive values. Figure 2 illustrates the generated impacts and the life cycle steps that contribute the most to each category. The contribution of the decantation step is very high compared to all others life cycle steps (between 62 % and 99 %) except for ionizing radiation, eutrophication (freshwater), land use and resource use (minerals and metals). Decantation process is realized thanks to a significant amount of dichloromethane, and dichloromethane production is responsible of the impacts.

Drying of digestate is the main contributor of impacts on ionizing radiation (15 %) and resource use (minerals and metals) (30 %) and the second contributor for climate change, human toxicity (cancer) and resource use (fossils).

For the others categories, major impacts are induced whether by drying of solid digestate, anaerobic digestion or biomass preparation. Both digestate drying and anaerobic digestion require large amount of heat produced by gas boiler, which explain impacts on climate change due to greenhouse gas (GHG) emissions.

However, the integrated process generates electricity and heat thanks to cogeneration, which allow reducing energy consumption, leading to avoided impacts. Avoided production of heat and electricity thanks to biogas cogeneration contributes to a diminution for fifteen categories (from -9 % to -70 %).

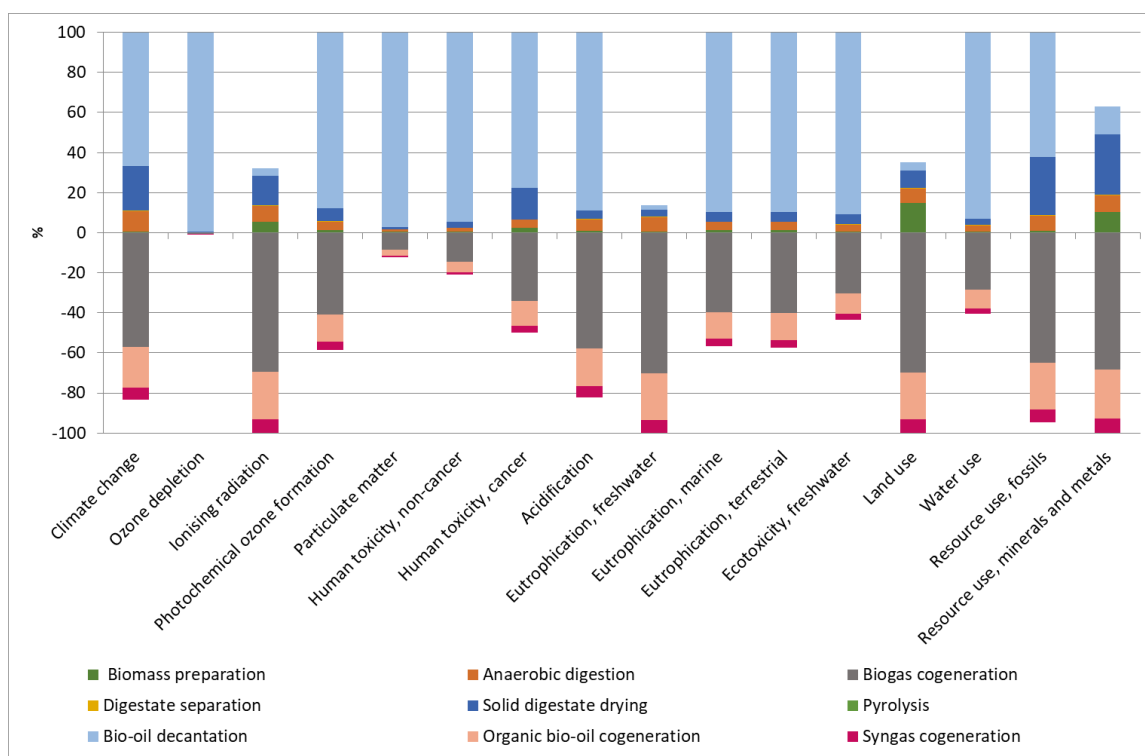

Figure 2 – Life cycle steps contribution to generated environmental impacts, using SimaPro and EF 3.0 method.

#### 4. Discussion

Coupling anaerobic digestion with pyrolysis is a promising process which allows to handle waste while producing energy and a fertilizing component. However, the process has some drawbacks and it is interesting to address the contribution of pyrolysis compare to a process of anaerobic digestion alone. Integrated process certainly counterbalance AD disadvantages: energy produced by biogas cogeneration is used to dry digestate instead of being lost, energy potential of some residual organic substances in digestate is enhanced thanks to pyrolysis and finally, biochar produced is supposed to have better properties than digestate. However, the results of life cycle assessment underline that bio-oil decantation has non-negligible impacts because of dichloromethane use. Different results were obtained in previous studies about integrated AD and pyrolysis system (Cao and Pawłowski, 2013) because bio-oil was directly sent to CHP system without decantation step. In this study, if decantation is omitted, the most impactful steps are solid digestate drying and anaerobic digestion, and the calculated GHG emission reduction per dry ton of biomass is 0.728 t CO<sub>2</sub> eq. Cao and Pawłowski, who evaluate GHG emissions, found similar conclusions: the main contributors are drying of biomass before pyrolysis and digestion, moreover they obtained GHG emission reduction equal to 0.47 t CO<sub>2</sub> eq per dry ton sludge (Cao and Pawłowski, 2013). Though, recovering both organic and aqueous phases of bio-oil is not useless. Firstly, as bio-oil is sent to CHP system, it is better to remove as much water as possible to raise its energetic potential. Secondly, aqueous bio-oil is said to have fungicide properties (Brassard et al., 2020). More research should be done to optimise decantation step, for instance by an integrated simulation of process and life cycle assessment, as presented by Busset et al., 2015.

In this study, the potential of biochar as carbon sequester (Monlau et al., 2015) and soil amendment (Cao and Pawłowski, 2013) is not evaluated. As for liquid digestate, it is also considered to have fertilizing properties as it is composed of a large amount of nutrients (nitrogen N, phosphorus P, potassium K). Liquid digestate can also be reintroduced in the digester to reduce water consumption. In a further study, liquid digestate will be spread along with biochar to enhance their potential (Hossain et al., 2010).

Others assumptions concerning entering biomass are interesting issues. Indeed, no environmental impacts were allocated to quinoa cultivation and harvesting, neither to wastewater treatment plant (WWTP). Sludge from WWTP are considered with zero burden in most of the LCA, but some authors decided to allocate impacts to WWTP as sludge are not only waste but also a source of phosphorus (P), an highly coveted non-renewable resource (Pradel et al., 2020).

## 5. Conclusion

Through a cradle-to-gate LCA, the environmental performance of a process coupling anaerobic digestion and pyrolysis for waste treatment is assessed. The study aims to emphasize an eventual potential of integrated systems compared to stand alone ones. Overall results show that the use of dichloromethane for bio-oil decantation generates high impacts for almost all categories under study. More research should be done to optimise decantation step. Otherwise, considering avoided production of heat and electricity play an important role as these avoided production contribute to decrease impacts of almost all categories. Perspective to this first work, the overall environmental impacts of the process could be studied from a cradle-to-grave perspective, to take into account benefits or consequences of biochar, liquid digestate and aqueous bio-oil spread or use. Similarly, quinoa cultivation and harvesting and wastewater treatment plant could be integrated in the system boundaries, to eventually allocate impacts to these stages. All these issues will be at the core of future studies, along with a rigorous comparison between anaerobic digestion and integrated system with pyrolysis.

## Acknowledgments

This work was carried out within the framework of the Scientific Cooperation Agreement concluded between OCP, UM6P and INRAE.

## References

- Andriani, D., Rajani, A., Kusnadi, Santosa, A., Saepudin, A., Wresta, A., Atmaja, D., 2020. A review on biogas purification through hydrogen sulphide removal. IOP Conference Series: Earth and Environmental Science 483, 012034.
- Bailon Allegue, L., Hinge, J., 2014. Biogas upgrading - Evaluation of methods for H<sub>2</sub>S removal. Danish Technological Institute.
- Belaud, J.-P., Prioux, N., Vialle, C., Buche, P., Destercke, S., Sablayrolles, C., 2019. Framework for Sustainable Management of Agricultural By-product Valorization. Chem Eng Trans 74, 1255–1260.
- Brassard, P., Godbout, S., Hamelin, L., 2020. Framework for consequential life cycle assessment of pyrolysis biorefineries: A case study for the conversion of primary forestry residues. Renewable and Sustainable Energy Reviews 110549.
- Busset, G., Sablayrolles, C., Montréjaud-Vignoles, M., Vialle, C., Belaud, J.-P., 2015. Computer aided process engineering for sustainability analysis of food production. Chem Eng Trans 43, 1339–1344.
- Cao, Y., Pawłowski, A., 2013. Life cycle assessment of two emerging sewage sludge-to-energy systems: Evaluating energy and greenhouse gas emissions implications. Bioresource Technology 127, 81–91.
- Escudie, R., Cresson, R., 2017. Méthanisation de la biomasse. Techniques de l'ingénieur BIO 5 100 v2.
- European Commission, *PEFCR Guidance document*, Guidance for the development of Product Environmental Footprint Category Rules (PEFCRs), version 6.3, December 2017.
- Hossain, M.K., Strezov, V., Yin Chan, K., Nelson, P.F., 2010. Agronomic properties of wastewater sludge biochar and bioavailability of metals in production of cherry tomato (*Lycopersicon esculentum*). Chemosphere 78, 1167–1171.
- Monlau, F., Francavilla, M., Sambusiti, C., Antoniou, N., Solhy, A., Libutti, A., Zabaniotou, A., Barakat, A., Monteleone, M., 2016. Toward a functional integration of anaerobic digestion and pyrolysis for a sustainable resource management. Comparison between solid-digestate and its derived pyrochar as soil amendment. Applied Energy 169, 652–662.
- Monlau, F., Sambusiti, C., Ficara, E., Aboulkas, A., Barakat, A., Carrère, H., 2015. New opportunities for agricultural digestate valorization: current situation and perspectives. Energy Environ. Sci. 8, 2600–2621.
- Pecchi, M., Baratieri, M., 2019. Coupling anaerobic digestion with gasification, pyrolysis or hydrothermal carbonization: A review. Renewable and Sustainable Energy Reviews 105, 462–475.
- Pradel, M., Lippi, M., Daumer, M.-L., Aissani, L., 2020. Environmental performances of production and land application of sludge-based phosphate fertilizers—a life cycle assessment case study. Environ Sci Pollut Res 27, 2054–2070.
- Tayibi, S., Monlau, F., Marias, F., Cazaudehore, G., Fayoud, N.-E., Oukarroum, A., Zeroual, Y., Barakat, A., 2021. Coupling anaerobic digestion and pyrolysis processes for maximizing energy recovery and soil preservation according to the circular economy concept. Journal of Environmental Management 279, 111632.