

Effect of Seawater Alkalinity on the Performances of a Marine Diesel Engine Desulphurization Scrubber

Domenico Flagiello^{a,*}, Francesco Di Natale^a, Amedeo Lancia^a, Kent Salo^b

^a Department of Chemical, Materials and Production Engineering, University of Naples Federico II, P.le Tecchio, 80 - 80125 Naples, Italy

^b Maritime Studies, Department of Mechanics and Maritime Science, Chalmers University of Technology, Lindholmen Hörselgängen, 4 - SE-412 96 Gothenburg, Sweden

*corresponding: domenico.flagiello@unina.it

Since the last fifteen years, Flue Gas Desulphurization (FGD) plants based on seawater scrubbing found an interesting application in the maritime transportation, as an answer to the stringent regulations imposed by International Maritime Organization (IMO) on sulphur emissions. This work reports the experimental results on desulphurization in a pilot seawater scrubber (DN 400) from a marine Diesel engine (80 kW) operated under different loads (10, 25 and 50%). The pilot scrubber was fed with a gas velocity 0.15 m/s and a liquid to gas mass ratio 1 - 3 kg/kg. The scrubbing liquid was available at different alkalinity and salinity levels representing the ion speciation of marine water in different geographic areas. The experiments evaluate the SO₂ removal efficiency of the scrubber as a function of seawater alkalinity and pH.

Finally, the paper reports a correlation to assess the seawater flow rate required to comply with the current IMO restrictions. This correlation allows tuning the seawater flow rate during the ship navigation based on the registered marine alkalinities and to the operating conditions of the engine. The model can be integrated in the scrubber control system to identify optimal operating conditions and reduce pumping costs, helping to reduce the EEDI and the SEEMP ships energy indexes.

1. Introduction

In the field of Exhaust Gas Cleaning Systems (EGCS), scrubbing with water-based solutions is among the most widespread technology, largely adopted for gas desulphurization in power plants, waste municipal incinerators and industrial processes (Poullikkas, 2015; Flagiello et al., 2020a). In light of the environmental directives presented by the International Maritime Organization (IMO) on the control of sulphur emissions in shipping (Čampara et al., 2018), scrubbing processes spread out also in the maritime industry (Schultes et al., 2018; Iliuta and Larachi, 2019; Flagiello et al., 2019) as a valid alternative to the use of expensive MGO fuels with low-sulphur content or ultra-low sulphur fuel oil (ULSFO), which has the merit to reduce sulphur emissions but scarcely affects the emission factors of other pollutants (den Boer, 2015). Different sulphur limits apply for open ocean, ports and for the so-called Sulphur Emissions Control Areas (SECA): According to the IMO-Marpol Annex VI - Regulation 14, the equivalent sulphur emissions must be lower than 0.1% w/w in SECA regions, and lower than 0.5% w/w in open seas. One of the most convenient option for marine scrubbing is using simple seawater without additional chemicals (e.g. Kuang et al., 2019; Flagiello et al., 2020b). Indeed, SO₂ solubility in seawater is related to its natural content of dissolved alkaline species (carbonates and bicarbonates), which promote the formation of the dissociation products of H₂SO_{3(aq)}, the hydrated form of dissolved SO₂. The most important chemical reactions occurring in seawater are (Flagiello et al., 2018a):



where carbonates (CO_3^{2-}) and bicarbonates (HCO_3^-) represent the total alkalinity of the seawater which, through hydrolysis reactions with sulphur compounds ($\text{H}_2\text{SO}_{3(\text{aq})}$ and HSO_3^-), give carbonic acid and then $\text{CO}_{2(\text{g})}$. In the Mediterranean Sea and in the Oceans, the alkalinity of water is around 2.3 - 2.4 mmol/L, allowing an appreciable absorption of SO_2 . On the contrary, the Finland Gulf and Baltic Sea have a lower alkalinity (0.23 - 0.46 mmol/L) and a proportionally lower capacity to absorb SO_2 . However, seawater is also corrosive, due to the higher saline content, (around 33 - 37 g/L) leading to the need for special alloys for scrubbers and pipelines construction (Kjøholt et al., 2012; Flagiello, 2020). This is particularly relevant after scrubbing, where the pH reduction and the formation of sulphates gives rise to higher corrosive potentials.

An optimization of seawater consumption is necessary to define an appropriate sizing of the pumps, as well as to reduce the space required for the scrubber installation, which represent one of the main problems in marine applications. Seawater consumption also defines the actual energy consumption of the scrubber and the actual concentration of the main (sulphur compounds) and the secondary (particles, VOC and hydrocarbons) pollutants that are removed during the scrubber functioning. The operating seawater dosage in marine scrubbing desulphurization systems can be optimized on the basis of the ratio between seawater alkalinity and the amount of SO_2 in the flue-gas. However, this parameter varies in the different geographic areas, being higher at low latitudes and lower close to the poles.

In this work, we investigated the influence of seawater alkalinity on desulphurization efficiency of a marine scrubber. The experiments were performed in a pilot-plant installed in the Marine Engine Lab of the Chalmers University of Technology in Gothenburg (SE). The experimental set-up consisted of a spray scrubber connected to the exhaust pipeline of a Volvo PENTA marine Diesel engine (80 kW). The engine is operated at different engine loads, from 10 to 50%, to simulate different navigation regimes of a ship, from maneuvering to typical navigation operation. The pilot scrubber was made in stainless steel AISI 316L, with a DN 400 and total length 0.5 m, while the actual scrubbing length was 0.14 m. The scrubber was fed with a flue-gas stream at constant flow rate equal to $70 \text{ m}^3/\text{h}$ (0.15 m/s), with temperature and compositions variable with the engine load. The seawater was fed in counter-current to gas flow with different flow rates from 30 to 120 L/h at 20 °C. The experiments were carried out with four scrubbing liquids having alkalinity in the range 20 - 220 mg/L corresponding to the marine conditions of the Finland Gulf Sea, the North Sea, the Canary Sea and the Kattegat Sea, respectively. The experiments also showed the effect of seawater scrubbing on other gas pollutants (*i.e.* NO_x , CO and CO_2) and the temperatures of liquid and gas after the scrubber.

The principal aim of this work was to provide an experimentally based correlation to predict the scrubber desulphurization efficiency as a function of the operating seawater alkalinity and the sulphur content in the fuel. This correlation eventually allows to optimize the seawater flow rate required to comply with the IMO limitations on sulphur emissions imposed for SECA and open seas, as a function of the ship's route and the engine load.

2. Materials and Methods

2.1 Experimental pilot-plant

The flowsheet of the experimental pilot-plant, inclusive of all the column equipment and measuring and analytical instruments, is shown in Figure 1.

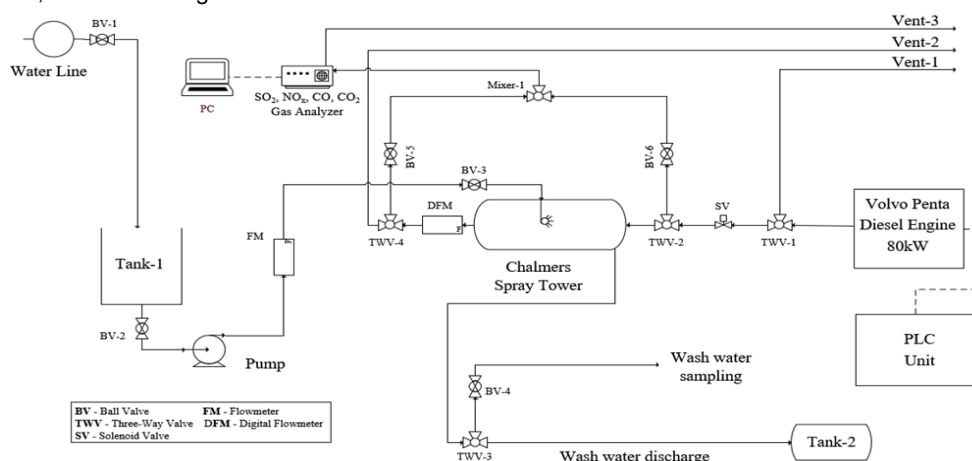

Figure 1: Flowsheet of the experimental pilot-plant

The experiments were performed in the Marine engine lab at Maritime Studies of the Department of Mechanics and Maritime Sciences, Chalmers University of Technology (Gothenburg, Sweden) using a Volvo Penta four-strokes 80 kW marine Diesel engine (D3-110) operated by fixing three different loads at 2000 rpm corresponding

to engine loads at 10, 25 and 50% of the rated maximum load. The engine was fed with a Marine Gas Oil (MGO) containing 0.92% w/w sulphur, whose chemical composition is reported in Flagiello (2020).

A PLC unit allowed to manage the engine rpm, the hydraulic torque, the cooling water and to control the temperatures and the pressure of the engine and of the support units. The engine data and the flue-gas characteristics are shown in Table 1 and Table 2.

Table 1: Engine data collected for different engine loads (10, 25 and 50%)

Engine Load	Engine Speed rpm	Hydraulic Torque N·m	Engine Power kW	Fuel Consumption L/h	Flue-gas Temperature °C
10%	2000	35	8.38	2.7±1	180±2
25%	2000	95	19.90	5.5±1	260±2
50%	2000	190	39.80	10.1±1	318±2

Table 2: Characteristic composition of flue-gas for different engine loads (10, 25 and 50%)

Engine Load	SO ₂ ppm _v	NO ppm _v	NO ₂ ppm _v	CO ppm _v	CO ₂ % v/v
10%	66±1	152±4	21±1	496±2	3.76±0.4
25%	132±2	318±2	33±2	189±3	5.95±0.5
50%	204±2	669±2	20±2	203±3	8.34±0.4

The pilot scale scrubber (i.d.: 0.4 m and total length: 0.5 m) was made in stainless steel AISI 316L and was positioned horizontally, unlike the common vertical scrubbers. A BETE® spray nozzle (HA 1.50 - 9020 model, made in stainless steel) was placed at 150 mm of distance from the flue-gas inlet into the scrubber.

The exhaust flue-gas generated by the Volvo engine was split in two streams: the first was sent to the lab ventilation system and emitted in the atmosphere and the second one was sent to the scrubber through a solenoid valve placed on the exhaust pipe. The pipe connecting the engine to the scrubber was made in Stainless Steel AISI 316L (i.d. 74 mm) and was thermally insulated. The flow rate, temperature and pressure of the flue-gas after the scrubber were measured by a portable analyzer (Testo 480 Multi-function). The seawater was fed by a frequency controlled progressing cavity pump (Getriebebau, 1.8 kW) and its flow rate was measured by a ROTA Yokogawa liquid rotameter.

The scrubbing liquids were artificial seawater solutions prepared starting from a sample of the Kattegat seawater, distilled water and sodium chloride at food grade, following the chemical composition data reported by Rodríguez-Sevilla et al. (2004) and Andreasen and Mayer (2007) to simulate the typical seawater composition of a given geographic area in terms of alkalinity and salinity. Table 3 resumes the characteristics of the adopted scrubbing liquids.

Table 3: Total alkalinity, pH and salinity values for different marine areas: the Finland Gulf Sea, the North Sea, the Canary Sea and the Kattegat Sea

Seawater characteristics	Finland Gulf Sea	North Sea	Canary Sea	Kattegat Sea
Total Alkalinity (sum of HCO ₃ ⁻ and CO ₃ ²⁻) [mg/L]	20	125	205	220
pH value	7.1	7.7	8.5	8.7
Salinity level [kg _{salt} /kg _{seawater}]	4	35	37	39

After the scrubber, the flue-gas stream was sent to gas analysis system to detect its composition. The gas analyzer was a Fuji Electric ZRE type NDIR (SO₂, NO, NO₂, CO and CO₂). Flue-gas sample was previously cleaned from the soot with hot filter (J.U.M. Engineering, heated sample filter 1128 model) and dried with gas quencher (Ankersmid Sampling gas cooler) at low temperature. The wash water was stored in a steel tank of about 5 m³ and then disposed. The water samples were collected in sampling bottles at the scrubber outlet for pH and temperature analysis using a portable pH-meter (pH Tester 30 with accuracy ±0.1 for pH).

2.2 Experimental methods

The pilot scrubber was fed with a flue-gas stream at constant flow rate 70 m³/h (0.15 m/s), and input concentrations of the gas pollutants was determined without the liquid feed. The characteristics and physical properties of the flue-gas deriving from the Volvo diesel engine were reported in the former Table 1 and Table

2. The seawater stream was sent in counter-current flow with the gas at different flow rate, from 30 to 120 L/h. The liquid was available at 20 °C, and 4 different liquids at different alkalinity values were tested (see Table 3). The output concentration levels of gas pollutants were monitored and recorded up to the steady state (about 5 minutes), and the wash water sample was taken from the bottom of the scrubber to analyze pH and temperature.

2.3 Calculation methods

The SO₂ removal efficiency (η_{SO_2}) was calculated as:

$$\eta_{SO_2} = \frac{C_{SO_2,in} - C_{SO_2,out}}{C_{SO_2,in}} \quad (5)$$

The operating dosage (d_{op}) expressed as the ratio between total alkalinity flow rate (Q_{Alk} , kmol/h) in liquid scrubbing and SO₂ flow rate (Q_S , kmol/h) in the flue-gas, was calculated by:

$$d_{op} = \frac{Q_{Alk}}{Q_S} = \frac{L_v \cdot A_T}{G_w \cdot C_{SO_2,in}} \cdot 10^{12} MW_G \quad (6)$$

where L_v [L/h] and G_w [kg/h] are the liquid and flue-gas flow rates, while A_T [mmol/L] is the total alkalinity concentration in fed seawater and MW_G [kg/kmol] is the average molecular weight of the flue-gas.

The IMO limitations for sulphur emission control areas and open seas (respectively named SECA and GLOBAL in the following) were translated into target removal efficiency on the bases of the sulphur content in the MGO fuel used (0.92% w/w) and the relative SO₂ emissions in the flue-gas estimated with the scrubber turned-off at different engine loads (see Table 2).

3. Results and Discussions

Figure 2 shows the SO₂ emissions (Figure 2A-C) and wash water pH (Figure 2D-F) at the scrubber exit as a function of the liquid to gas mass ratio (L/G) and parametric with the seawater alkalinity and the engine loads (10, 25 and 50%). The lines denote the maximum allowed SO₂ emissions in SECAs and open sea (GLOBAL).

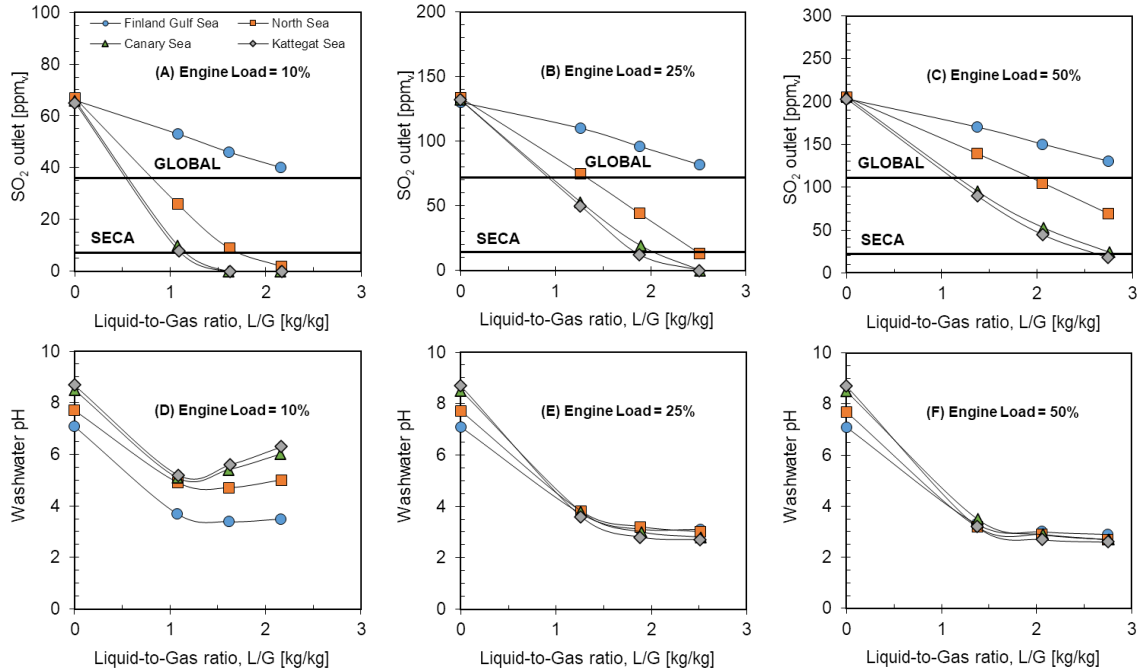

Figure 2: Experimental results of SO₂ outlet emission from scrubber (A,B,C) and wash water pH (D,E,F) as a function of the liquid-to-gas mass ratio (L/G) and parametric with four different seawater solutions (Finland Gulf Sea, North Sea, Canary Sea and Kattegat Sea) and three different engine loads (10, 25 and 50%). The lines in Fig. 2A-C denote the maximum allowed SO₂ emissions in SECAs and open sea (GLOBAL)

The results in Figure 2A-C showed that SO₂ emissions were reduced by an increase in the L/G ratio and identify the water flow rate required to comply with the SECA and GLOBAL emission target in the different conditions. When the engine load increased, the desulphurization process required a larger water flow rate to meet the emission targets because both the SO₂ level and the gas temperature increased. The Kattegat and Canary Sea

allowed to reach the targets with lower water flow rates compared to other liquids, thanks to a greater alkalinity content, as expected. In particular, SECA and GLOBAL emissions target can be achieved with a significant water-saving using the Kattegat and Canary Sea than North Sea, while for Finland Gulf Seawater, it was not possible to reach these targets within the experimental conditions.

During the experiments, no effect of the scrubbing process on other exhaust gas pollutants (NO_x , CO and CO_2) were observed, since they are practically insoluble in water, e.g. as reported for NO_x by Flagiello et al. (2021). The gas temperatures after scrubbing decreased due to the contact with the cold scrubbing liquids (20 °C) and the outlet values were in the range 50 - 70 °C.

Figure 2D-F showed that pH values in the wash water decreased with increasing L/G ratio and were consistent with increasing SO_2 absorption data. An exception appears in Figure 2D for the low engine load: in this case, apart for the case of the Finland Gulf Seawater, which, at the investigated dosage was not able to provide a significant removal of SO_2 , all the other seawater samples gave rise to an increase of pH when the complete SO_2 removal was achieved, starting from a $L/G = 1.6$ kg/kg.

In order to comply with IMO guidelines (Resolution MEPC 184 (59)) on washwater pH, requiring a pH > 6.5 at 4 m from the discharge point, scrubber washwater is often mixed with fresh seawater, often deriving from the engine cooling system. The experimental pH levels is consistent with normal seawater scrubbing systems, and usually the ratio between scrubber washwater and cooling water adopted is within 1:2 (United States Environmental Protection Agency, 2011). The temperature of the effluents after the scrubber remained almost unvaried with the engine load (in the range 30 - 50 °C), probably due to the water evaporation and the heat losses of the scrubber unit. The mixing of scrubber washwater and cooling water is sufficient to meet the maximum allowed temperatures limit of 40 °C suggested by IMO guidelines (Resolution MEPC 184 (59)).

The experimental results are reported in terms of SO_2 removal efficiency and the operating dosage (d_{op}), and showed in Figure 3.

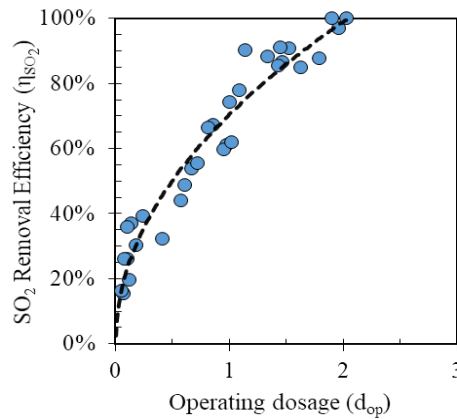

Figure 3: Experimental and modelling results of SO_2 removal efficiency as function of the operating dosage (d_{op})

Figure 3 shows that a > 99% removal was possible to achieve when the total alkalinity moles (sum of HCO_3^- and CO_3^-) were approximately twice the SO_2 moles in the fed flue-gas. The same operating dosage was also found in Flagiello et al. (2020c) with FGD experiments in a packed column.

Desulphurization efficiency (η_{SO_2}) was adequately described by a power law function model:

$$\eta_{\text{SO}_2} = 0.705 \cdot d_{op}^{0.49} \quad (7)$$

with exponent equal to 0.49 of the operating dosage (d_{op}). The modelling equation was able to predicts experimental data with a very good accuracy ($R^2 = 0.957$), and its range of validity was from 0 to 2.04 of d_{op} .

The application of this correlation on a scrubbing system installed on board the ship, would allow the optimization of seawater consumption during its route shipping. Indeed, once the flue-gas flow rate, its SO_2 content and the desulphurization efficiency to meet the IMO-Marpol targets have been set, this model is able to calculate the suitable seawater flow rate requested by marine scrubber installed on board ship during the navigation route.

4. Conclusions

This work provides an experimental study on flue-gas desulphurization in a marine pilot scrubber running with a Volvo Penta four-strokes 80 kW marine Diesel engine (D3-110) fueled with a MGO fuel with 0.92% w/w sulphur content. The experiments aimed to assess the optimal dosage of seawater in a marine scrubber operating on board ship during its navigation route, including low-speed maneuvers near ports.

The experiments show how the scrubber SO₂ efficiency improved with an increase in seawater flow rate and alkalinity level. Besides, a larger water consumption was needed to meet IMO targets when engine load increased from 10 to 50%, generally a water-saving greater than 50% could be achieved with Canary and Kattegat Sea compared to the North Sea. This effect was due to an alkalinity content which was approximately 2 times higher than the North Sea. Conversely, for the Finland Gulf Sea having a very low alkalinity content, a seawater flow rate outside the investigated range is required to reach IMO targets. The pH values of effluent after the scrubber were in the range 3 - 6 in line with the regulations for discharged waters on board ship according to IMO guidelines 2009 (Resolution MEPC 184 (59)).

The experimental data for the SO₂ scrubber capture for different engine loads, seawater flow rates and characteristic values of seawater alkalinity have been interpreted in the light of an experimental correlation which correlates the desulphurization efficiency to the operating dosage (d_{op}), with high accuracy level ($R^2 = 0.957$). The model provides a simple criterion to establish the optimal water dosage, able to control and optimize the seawater flow rate suitable for the reduction of sulphur emissions to meet IMO-Marpol targets according to the ships route. Seawater consumption plays an important role on pumping costs related to energy ship consumption, and a more accurate evaluation should be necessary (Flagiello et al., 2019). In this sense, the possible reduction of energy consumption allows contributing to reduce the fuel penalty and the additional GHG emission associated to the scrubber and to reduce the EEDI and the SEEMP ship index, contributing to enforce the IMO strategy and greening of the maritime transport.

Acknowledgments

The Authors warmly acknowledge Ph.D. Martina Esposito for the support in the experimentation.

References

- Andreasen A., Mayer S., 2007, Use of Seawater Scrubbing for SO₂ Removal from Marine Engine Exhaust, *Energy & Fuels*, 21:5, 3274–3279.
- Čampara L., Hasanspahić N., Vujičić S., 2018, Overview of MARPOL ANNEX VI regulations for prevention of air pollution from marine diesel engines, in *SHS Web of Conferences*, 58, EDP Sciences.
- den Boer E., Hoen, M., 2015, Scrubbers – An economic and ecological assessment, *CE Delft*
- Flagiello D., Di Natale F., Carotenuto C., Erto A., Lancia A., 2018a, Seawater Desulphurization of Simulated Flue Gas in Spray and Packed Columns: an Experimental and Modelling Comparison, *CET*, 69, 799–804.
- Flagiello D., Erto A., Lancia A., Di Natale F., 2018b, Experimental and modelling analysis of seawater scrubbers for sulphur dioxide removal from flue-gas, *Fuel*, 214, 254–263.
- Flagiello D., Parisi A., Lancia A., Carotenuto C., Erto A., Di Natale F., 2019, Seawater desulphurization scrubbing in spray and packed columns for a 4.35 MW marine diesel engine, *ChERD*, 148, 56–67.
- Flagiello D., Erto A., Lancia A., Di Natale F., 2020a, Dataset of wet desulphurization scrubbing in a column packed with Mellapak 250.X, *Data in Brief*, 33, 106383.
- Flagiello D., Di Natale F., Lancia A., Erto A., 2020b, Characterization of mass transfer coefficients and pressure drops for packed towers with Mellapak 250.X, *ChERD*, 161, 340–356.
- Flagiello D., Di Natale F., Erto A., Lancia A., 2020c, Wet oxidation scrubbing (WOS) for flue-gas desulphurization using sodium chlorite seawater solutions, *Fuel*, 277, 118055.
- Flagiello D., 2020, Enhanced seawater scrubbing for flue-gas cleaning, PhD Thesis, University of Naples - Federico II, Naples, IT.
- Flagiello, D., Di Natale, F., Erto, A., Lancia, A., 2021, Oxidative Scrubber for NO_x Emission Control Using NaClO₂ Aqueous Solutions, *CET*, 86.
- Iliuta I., Larachi F., 2019, Modeling and simulations of NO_x and SO₂ seawater scrubbing in packed-bed columns for marine applications, *Catalysts*, 9:6, 489.
- Kjølholt J., Aakre S., Jørgensen C., Lauridsen J., 2012, Assessment of Possible Impacts of Scrubber Water Discharges on the Marine Environment.
- Kuang M. et al., 2019, Seawater/alkaline liquid cascade-scrubbing desulfurization performance for the exhaust gas of a 162-kW marine diesel engine, *Asia-Pac. J. Chem. Eng.*, 14:6, e2370.
- Notteboom T., 2011, The impact of low sulphur fuel requirements in shipping on the competitiveness of ro-ro shipping in Northern Europe, *WMU Journal of Maritime Affairs*, 10:1, 63–95.
- Rodríguez-Sevilla J., Álvarez M., Díaz M.C., Marrero M.C., 2004, Absorption equilibria of dilute SO₂ in seawater, *J. Chem. Eng. Data*, 49:6, 1710–1716.
- Schultes M., Brauer J., Chen P., Doong S., 2018, Marinization of mass transfer columns for FLNG applications, *CET*, 69, 301-306
- United States Environmental Protection Agency, 2011, Exhaust Gas Scrubber Washwater Effluent, Office of Wastewater Management Washington, DC 20460.