

Process Superstructure Optimization for Resin and Aromatic Monomer Production from Kraft Lignin

Christos Galanopoulos^a, Aristide Giuliano^{b,*}, Apostolis Koutinas^a, Isabella De Bari^b, Diego Barletta^c

^a Department of Food Science and Human Nutrition, Agricultural University of Athens, Iera Odos 75, Athens, 11855, Greece

^b ENEA, Italian National Agency for New Technologies, Energy and Sustainable Economic Development, S.S. 106 Ionica, km 419+500, Rotondella, MT, Italy

^c Dipartimento di Ingegneria Industriale, Università degli Studi di Salerno, Via Giovanni Paolo II 132, I-84084 Fisciano SA, Italy

aristide.giuliano@enea.it

Kraft lignin conversion to value-added products is an alternative way to manage the main pulp and paper secondary stream thus contributing to reducing avoid greenhouse gas emissions compared to equivalent fossil-based processes. Process simulation and integration can help to identify the most promising pathways and increase the profitability of the process. This work presents results of a comparison between the process optimization of two different potential products that were modeled and analyzed. Aromatic monomers and phenol-formaldehyde resins were considered as possible products by means of alternative process pathways, including hydrothermal liquefaction, hydrodeoxygenation, pyrolysis, dissolution with deep eutectic solvents, hot water extraction, and resin synthesis. Mixed-integer nonlinear programming was applied to optimize the superstructure and obtain the maximum lignin cost. A sensitivity analysis in terms of the final products selling price was performed to consider the market variability. Minimum selling prices of aromatic monomers and phenol-formaldehyde resins for a feasible lignin process were calculated. Maximum lignin cost larger than 100 €/t resulted acceptable only for phenol-formaldehyde resins selling price larger than 0.6 €/kg or for AM selling price larger than 1.80 €/kg. Aromatic monomers turned out to be the optimal product if its selling price is larger 1.20 €/kg and the phenol-formaldehyde resins cost is lower than or equal to 0.6 €/kg. Higher phenol-formaldehyde resins selling prices make this product more convenient.

1. Introduction

Lignin represents about 20-35%_{DRY} of lignocellulosic biomass and can be separated from cellulose and hemicellulose by several processes. The kraft process, used in the paper industry, produces a lignin-rich stream as a waste. As a result, the kraft lignin is the most widespread technical lignin and its valorization can help to solve the disposal problems and contribute to reducing GHG emissions compared to equivalent fossil-based processes (Solarte-Toro et al., 2018). Valorization processes to value-added chemicals need to be optimized in order to assess their convenience with respect to the common energy conversion (Giuliano et al., 2020b). A huge research effort has been devoted to find more convenient lignin conversion technologies (Yadav, 2020). In particular, novel technologies allow to obtain aromatic hydrocarbons and/or phenol-formaldehyde resins (Biziks et al., 2020). All these processes can be compared to identify the most profitable, from an economic and an environmental point of view, by means of a process system design and optimization methods. Process simulation and design have been widely used to carry out economic analysis of biorefineries processing lignocellulosic biomass (Giuliano et al., 2019). More recently, a few works addressed the techno-economic analysis of the lignin valorization routes in biorefineries. Mabrouk et al. (2017) reported interesting results for the production of catechol through lignin depolymerization, extraction and separation by a distillation train. Abdelaziz et al. (2020) performed a techno-economic analysis for chemicals production from kraft lignin. Process synthesis, simulation, and integration were carried out for the assessment of the potential oxidative

depolymerization viability with respect to vanillin production on a scale of 700 kt/y of fresh lignin feed. Shen et al., 2018 derived the minimum selling price of jet fuel derived from lignin as a co-product in a lignocellulosic biorefinery producing 2000 t/day of ethanol. Gursel et al. (2019) compared lignin pyrolysis, direct hydrodeoxygenation (HDO), and hydrothermal upgrading to obtain mixed oxygenated aromatic monomers, light organics, heavy organics, and char. Direct hydrodeoxygenation resulted in the most promising process. Alternative process pathways can be included in a superstructure and the optimal flowsheet and the optimal feedstock allocation to the target products can be found by means of Mixed Integer Programming (MIP). In particular, Giuliano et al., (2020a) solved a Mixed Integer Linear Problem to optimize a superstructure including process routes from lignin to jet-fuels, phenol-formaldehyde resins, polyurethane foams, and syngas for green electricity generation. Their preliminary results suggested that phenol-formaldehyde resins appear more suitable to the market. Tey et al. (2021) derived the optimal production pathways to manufacture bulk chemicals, fine chemicals and pharmaceutical products from lignin in an integrated biorefinery. The promising product from lignin processing was formaldehyde.

In this work, two different potential products derived from lignin, aromatic monomers and phenol-formaldehyde resins (PFR), were considered through several alternative process routes. A simplified approach based on Mixed Integer Non-Linear Programming is presented and applied to find the optimal kraft lignin allocation to products and the optimal relevant processes aiming at an economic objective function. In particular, a sensitivity analysis based on the product selling prices was performed. In this way, the minimum selling price of the optimal product was identified, comparing it with the minimum selling price to make convenient the other product.

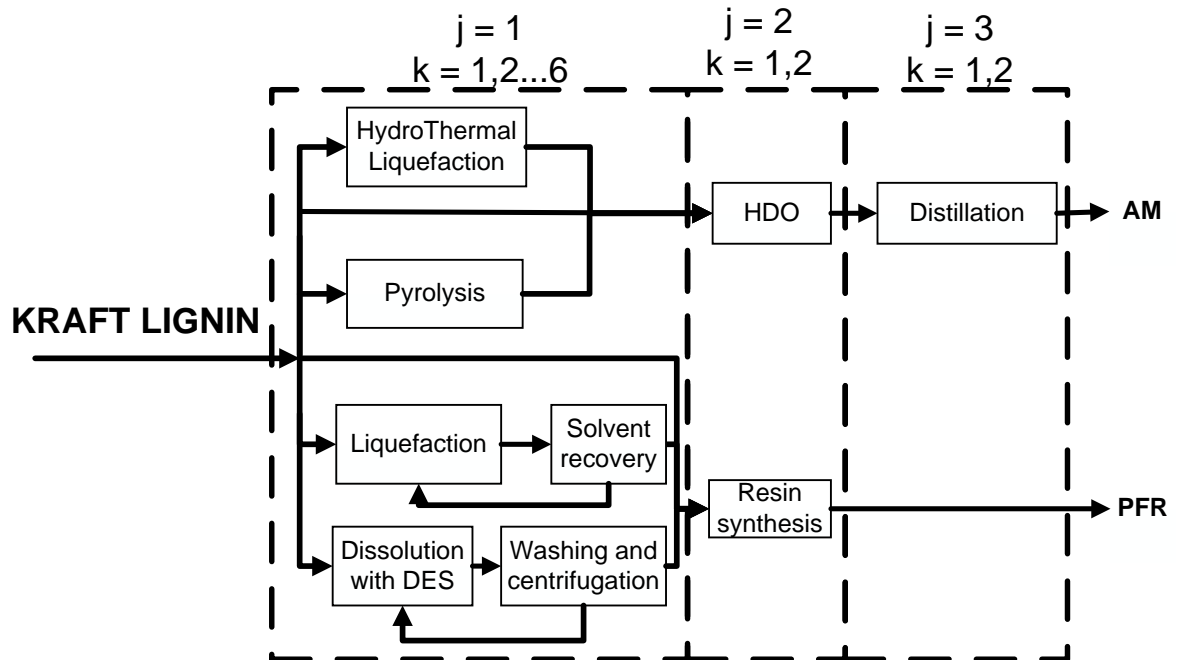

Figure 1: Superstructure of the kraft lignin-based biorefinery

2. Methods

2.1 MINLP model description

The optimization problem consists of finding the optimal process flowsheet and the optimal feedstock allocation to products for a lignin-based biorefinery, given an objective function (Giuliano et al., 2014). For this aim, the process pathways were included in a superstructure with different processing steps organized in three layers (Galanopoulos et al., 2019). On the first layer, there are three different sections j (pretreatment, synthesis, purification). Each section includes up to six alternative operations k (second layer) and each operation consists of up to 2 different process units p (third layer). After optimization, each layer j is restricted to only one operation option k . The lignin-based biorefinery optimization problem aims at deciding which route to take through the network and the relevant flows entering and leaving each layer in order to maximize the Maximum Lignin Cost, MLC . The latter MLC was derived as the maximum cost of dry lignin allowing a positive net profit from the biorefinery operations:

$$MLC = \max c_L \quad (1)$$

Where c_L is the lignin cost. To set the economic analysis, the following constraints were considered:

$$\begin{cases} NetProfit = F_{3,AM}p_{AM} + F_{3,PFR}p_{PFR} - TAC - AIC = 0 \\ TAC = RMC + WWC + UTC + OMC \\ RMC = F_a c_a + F_{IN,L} c_L \end{cases} \quad (2)$$

where $F_{3,AM}$, $F_{3,PFR}$ are the flowrate of aromatic monomers and phenol-formaldehyde resins respectively, p_{AM} , p_{PFR} are the product selling prices, TAC are the Total Annual Costs, AIC are the Annualized Investment Costs, RMC are the Raw Material Costs, WWC are the wastewater treatment costs, UTC are the Utilities Costs, OMC are the Operating & Maintenance Costs, F_a are the auxiliaries material flowrates, c_a are the chemicals/auxiliaries costs (listed in Table 1), $F_{IN,L}$ is the dry lignin feedstock flowrate. The AIC calculation for each process operation k was performed by means of power-law functions of the input flowrate. In particular, the parameters for the calculation of capital cost were obtained from Hamelinck et al. (2005). The annualization factor was set up as in the work of Galanopoulos et al. (2019). To consider the kraft lignin as a complex material composed of different molecular weights, reactivities and functional groups, a percentage by weight of the whole dry lignin was assumed to be reactive in depolymerization processes.

Table 1: Chemicals, solvents, reactants costs considered in the economic analysis

	Section of the superstructure	Cost
	j, k	€/kg
Hydrogen	2, 1	2.00
Ethanol	1, 5	0.50
DES	1, 6	0.80
H ₂ SO ₄	1, 1	0.08
NaOH	1, 1	0.15
Formaldehyde	2, 2	0.60

2.2 Process superstructure description

A superstructure of the lignin-based biorefinery was built with the most commonly used pathways according to an accurate literature survey. In particular, it consists of six lignin pretreatment routes, two product synthesis processes and two purification technologies, which can be summarised as follows

$j=1; k=1$: the hydrothermal upgrading is used to convert lignin to monomers by depolymerization. Water/NaOH solution at a medium temperature (200–350°C) and high pressure (> 40 bar) with a liquid-to-solid ratio of 5 kg/kg is considered to dissolve lignin. The reactor performance on the available lignin is assumed according to Gursel et al. (2019) findings;

$j=1; k=2$: the dry lignin is sent directly to the hydrodeoxygenation (HDO) reactor. In this case, a lower AM yield in the HDO can be obtained;

$j=1; k=3$: the thermochemical process of pyrolysis is used to break down lignin, by means of heat and in the absence of oxygen, to obtain the aromatics (Gursel et al., 2019);

$j=1; k=4$: the dry lignin is sent directly to the phenol-formaldehyde resin synthesis (Kalami et al., 2017). Without the pretreatment, lower molecular weight lignin can be effectively converted to resins;

$j=1; k=5$: a bio-crude oil is produced by the hydrothermal liquefaction process. Lignin is sent to the reactor with a water-ethanol (1:1 v/v) solvent. The reactor is operated at 350 °C and 20 bar (Paysepar et al., 2020);

$j=1; k=6$: a Zn-based Deep Eutectic Solvent (DES) is used to dissolve and transform the lignin by a low-energy process (100°C). Polyphenols in solution can be incorporated into the next phenol-formaldehyde resins synthesis (Hong et al., 2020);

$j=2; k=1$: HDO process is the main process step to produce the AMs from lignin. A mixed oxygenated aromatic monomers stream is obtained at 400°C and 150 bar with a percentage of hydrogen equal to 3%wt (Shen et al., 2018);

$j=2; k=2$: resins synthesis is performed by mixtures of lignin-water-NaOH-formaldehyde at 80°C (Paysepar et al., 2020);

$j=3; k=1$: a distillation train is used in order to purify the AMs. First, the light organics are separated by distillation due to their lower boiling point. A second distillation column is used to separate water from the other

components. Finally, AMs are completely separated from the high-boiling heavy organics in a third distillation column.

$j=3$; $k=2$: a purification process for PFRs is not necessary.

Table 2 reports the model parameters used in this work. In particular, the size of the biorefineries is an essential parameter to make the plants convenient and environmentally sustainable (Galanopoulos et al., 2020). Considering the possibility of collecting the feedstock in a limited area, e.g. near a paper factory, the input flowrate to the plant was assumed 180,000 t/y of dry kraft lignin.

Table 2: Economic and process parameters used in the superstructure optimization model.

Model parameter	Value
Dry lignin feedstock (t/y)	180'000
Hour per year (h/y)	7200
EtOH/Lignin	6.1
DES/Lignin	10
Discount rate (%)	8
Maintenance & Operating/Capital Costs (%)	10
Wastewater purification cost (€/t)	0.53
Electricity cost (€/MWh)	150
Lifetime (y)	20

3. Results

The results of this work consist in the *MLC* value which makes the overall layout economically viable. Values of *MLC* lower than 50 €/t are considered too low (Giuliano et al., 2020a), as the cost of producing/processing the feedstock to make it suitable for pre-treatment can be high. Other economic results consist in the capital costs to build the lignin valorization biorefinery. Capital costs higher than 150 M€ for about 200'000 t/y of feedstock are considered too expensive because higher than the capital costs of a lignocellulosic biorefinery producing bioethanol (Chemicals-technology, 2020). The operating costs play the main role, as the consumption of utilities (especially medium pressure steam), the consumption of chemicals or solvents (even if solvent recycling were considered) can vary depending on the process pathways.

3.1 Sensitivity analysis on the product selling price

In order to evaluate the impact on the optimization of two main economic parameters, a sensitivity analysis varying the selling prices of PFRs and AMs was performed. The base price of AM, assumed equal to 1.20 €/kg (Shen et al., 2018), was increased and decreasing by 50%. Because of the different final performance of resins is difficult to evaluate in the present analysis, the PFR selling price was varied in a wider range between 0.10 €/kg and 1.00 €/kg. Figure 2 reports *MLC*, *CC* and *OC* as a function of the AM price and PFR price. The main expected result consists of a general decrease of the *MLC* with decreasing p_{PFR} . In particular, for the case of $p_{AM}=0.60$ €/kg a minimum value of p_{PFR} equal to 0.40 €/kg is necessary to obtain a non-negative *MLC* value. For $p_{PFR}>0.60$ €/kg the optimal product is always the PFR, whatever is the AM price in the investigated range. For higher values of p_{AM} (1.20 and 1.80 €/kg) a threshold value for p_{PFR} is observed, below which the *MLC* value remains constant and positive. In particular, for p_{AM} equal to 1.20 €/kg, AM is the optimal product only for $p_{PFR} < 0.40$ €/kg with a very low *MLC* (about 12 €/t). For p_{AM} equal to 1.80 €/kg, AM is the optimal product for $p_{PFR} < 0.60$ €/kg, with a higher *MLC* (196 €/t). Capital costs are not very variable with the product prices since the same process path leads to the same capital costs. In particular, when AMs are produced, the process with hydrothermal upgrading is to be preferred, with investment costs of 155 M€. When PFR is the optimal product, liquefaction results the preferred pre-treatment process at low p_{PFR} values, while dissolution with DES solvents arises for high p_{PFR} values (>0.80 €/kg). In the latter case, the capital costs are higher and equal to 181 M€. In fact, obtaining a higher yield to PFR by means of the more expensive pretreatment with DES is justified by the higher PFR selling price. Operating costs follow a similar variation with the product prices. In the case of AM production, the *OC* amount to about 50 M€/y, mainly due to hydrogen consumption and utilities. In the case of PFR production, when liquefaction is the optimal pre-treatment, the *OC* are equal to 15 M€/y due to the consumption of formaldehyde. Differently, they increase up to 84 M€/y due to the DES make-up cost. The use of DES as a solvent to treat lignin is an opportunity especially from the point of view of the high yields and low temperature of the process. The production of PFRs is optimal considering even low sales prices (greater than 0.30 €/kg), however, the technical performance of lignin-based PFRs compared to the conventional ones remains unknown. The AMs compounds are an opportunity to valorize the lignin only if each component is

fractionated and sold separately, avoiding the mix of aromatic compounds that reduces their value too much. The advantage, in that case, consists in selling any pure compound (eg vanillin, cresol, catechol, etc.) at very high prices, even higher than 20 €/kg. The limit of the analysis proposed in this work consists of not being able to consider the difference between a kraft lignin and lignin obtained differently. Further modeling analysis must be proposed to make the model depends on the type of lignin being considered. Furthermore, this analysis does not take into account the different performances of the use of lignin-based compounds compared to the compounds obtained through conventional processes (eg resins).

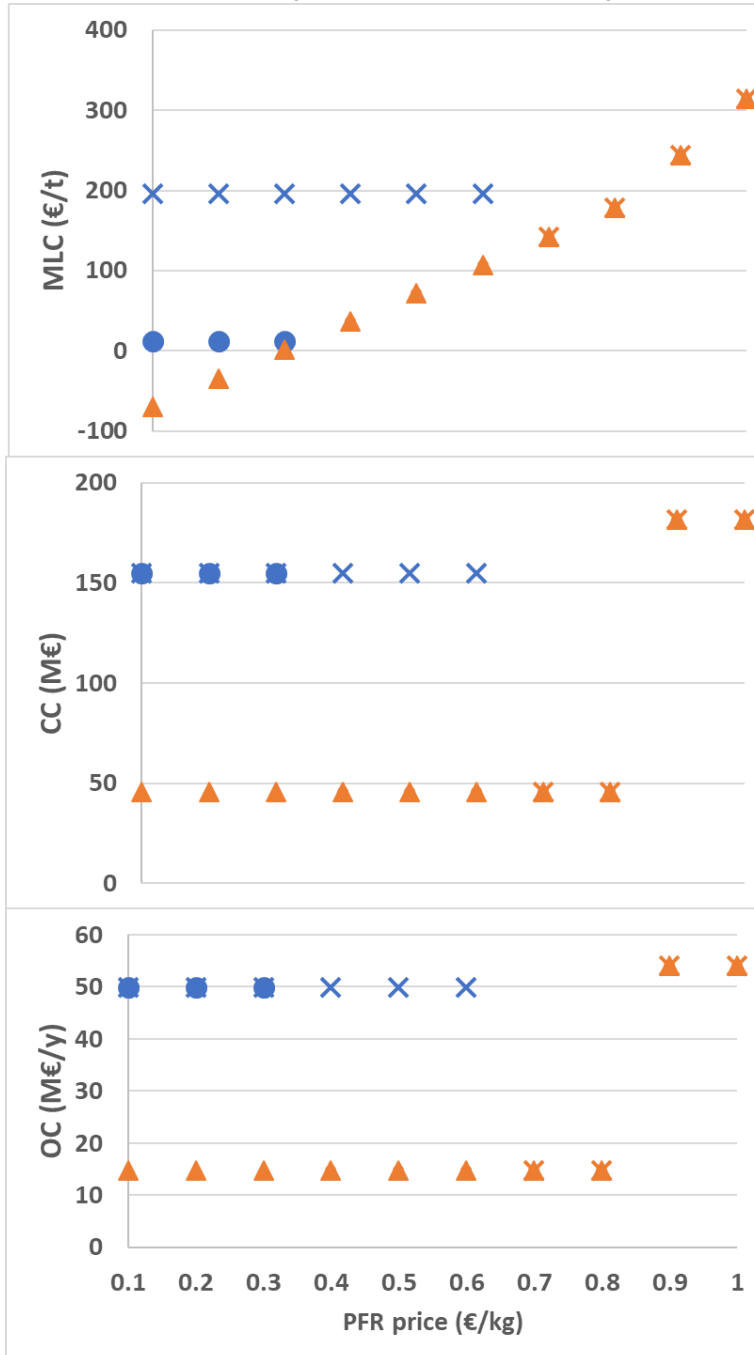

Figure 2: Maximum Lignin Cost (MLC), capital costs (CC), operating costs (OC) as a function of the PFR and parametric in the AM selling price: ▲ 0.60 €/kg; ● 1.20 €/kg; × 1.80 €/kg. Blue symbols correspond to AM as the optimal product, orange symbols correspond to PFR as the optimal product.

4. Conclusions

In this work, some alternative processes to valorize kraft lignin were compared on economic ground. Aromatic monomers and phenol-formaldehyde resins were considered as lignin-based products. A simplified approach based on the optimization of a process superstructure by means of MINLP was used. A sensitivity analysis was performed, in order to assess the effect of the product selling prices. Results show that it is not convenient to process the lignin when the PFR selling price and the AM selling price are lower than 0.40 €/kg and 1.20 €/kg, respectively. Maximum lignin cost larger than 100 €/t is acceptable only for PFR selling price larger than 0.6 €/kg or for AM selling price larger than 1.80 €/kg. In particular, AM is the optimal product if its selling price is larger 1.20 €/kg and the PFR cost is lower than or equal to 0.6 €/kg. Higher PFR selling prices make this product more convenient.

Acknowledgments

This paper was funded by IEA Bioenergy Task 42 'Biorefining in a Circular Economy' and by the COST Action LignoCOST (CA17128), supported by COST (European Cooperation in Science and Technology).

References

- Abdelaziz O.Y., Al-Rabiah A.A., El-Halwagi M.M., Hulteberg C.P., 2020. Conceptual Design of a Kraft Lignin Biorefinery for the Production of Valuable Chemicals via Oxidative Depolymerization. *ACS Sustain. Chem. Eng.* 8, 8823–8829.
- Biziks V., Fleckenstein M., Mai C., Miltz H., 2020. Suitability of a lignin-derived mono-phenol mimic to replace phenol in phenol-formaldehyde resin for use in wood treatment. *Holzforschung* 74, 344–350.
- Chemicals-technology, 2020, Beta Renewables Cellulosic Ethanol Biorefinery, Crescentino. <https://www.chemicals-technology.com/projects/mg-ethanol/>
- Galanopoulos C., Giuliano A., Barletta D., Zondervan E., 2020. An integrated methodology for the economic and environmental assessment of a biorefinery supply chain. *Chem. Eng. Res. Des.* 160, 199–215.
- Galanopoulos C., Kenkel P., Zondervan E., 2019. Superstructure optimization of an integrated algae biorefinery HG SB SC SO SUP 130.
- Giuliano A., Barletta D., De Bari I., 2020a. Optimization of a lignin valorization process superstructure using a MILP approach. *Chem. Eng. Trans.* 80, 229–234.
- Giuliano A., Catizzone E., Freda C., Cornacchia G., 2020b. Valorization of OFMSW Digestate-Derived Syngas toward Methanol, Hydrogen, or Electricity: Process Simulation and Carbon Footprint Calculation.
- Giuliano A., Cerulli R., Poletto M., Raiconi G., Barletta D., 2014. Optimization of a Multiproduct Lignocellulosic Biorefinery using a MILP Approximation. *Comput. Aided Chem. Eng.* 1423–1428.
- Giuliano A., De Bari I., Motola V., Pierro N., Giocoli A., Barletta D., 2019. Techno-environmental Assessment of Two Biorefinery Systems to Valorize the Residual Lignocellulosic Biomass of the Basilicata Region. *Math. Model. Eng. Probl.* 6, 317–323.
- Gursel V.I., Dijkstra J.W., Huijgen W.J.J., Ramirez A., 2019. Techno-economic comparative assessment of novel lignin depolymerization routes to bio-based aromatics. *Biofuels, Bioprod. Biorefining* 13, 1068–1084.
- Hamelinck C.N., Van Hooijdonk G., Faaij A.P.C., 2005. Ethanol from lignocellulosic biomass: Techno-economic performance in short-, middle- and long-term. *Biomass and Bioenergy* 28, 384–410.
- Hong S., Sun X., Lian H., Pojman J.A., Mota-Morales J.D., 2020. Zinc chloride/acetamide deep eutectic solvent-mediated fractionation of lignin produces high- and low-molecular-weight fillers for phenol-formaldehyde resins. *J. Appl. Polym. Sci.* 137, 1–9.
- Kalami S., Arefmanesh M., Master E., Nejad M., 2017. Replacing 100 % of phenol in phenolic adhesive formulations with lignin 45124, 1–9.
- Mabrouk A., Erdocia X., Alriols M.G., Labidi J., 2017. Techno-economic evaluation for feasibility of lignin valorisation process for the production of bio-based chemicals. *Chem. Eng. Trans.* 61, 427–432.
- Paysepar H., Hu Y., Feng S., Yuan Z., Shui H., Xu C. (Charles), 2020. Bio-phenol formaldehyde (BPF) resoles prepared using phenolic extracts from the biocrude oils derived from hydrothermal liquefaction of hydrolysis lignin. *React. Funct. Polym.* 146, 104442.
- Shen R., Tao L., Yang B., 2018. Techno-economic analysis of jet-fuel production from biorefinery waste lignin. *Biofuels, Bioprod. Biorefining* 13, 486–501.
- Tey T.O., Chen S., Cheong Z.X., Choong A.S.X., Ng L.Y., Chemmangattuvalappil, N.G., 2021. Synthesis of a sustainable integrated biorefinery to produce value-added chemicals from palm-based biomass via mathematical optimisation. *Sustain. Prod. Consum.* 26, 288–315.
- Yadav V.G., 2020. Biovalorization of lignin. *Chem. Eng. Trans.* 80, 283–288.