



Thermodynamic study on the feasibility of a new combined chemical looping process for syngas production

Alba Storione^{a,*}, Matteo Minelli^a, Ferruccio Doghieri^a, Elena Landi^b, Francesco Miccio^b

^aDICAM, Alma Mater Studiorum Università di Bologna, Bologna, Italy

^bCNR-ISTEC, National Research Council - Institute of Science and Technology for Ceramics, Faenza, Italy
alba.storione2@unibo.it

Methane Chemical Looping mixed dry reforming – CLMDR (dry reforming and partial oxidation) is an integrate process that utilizes CO₂ directly, in presence of carrier materials, for the production of syngas with tuneable H₂/CO molar ratio. Herein Cerium oxide was selected as reference source of oxygen and its use in the CLMDR process was evaluated by means of thermodynamic tools of Aspen Plus process simulator. Crucial features such as reforming and regeneration operative temperature, oxygen to methane molar ratio and CO₂ addition were investigated in order to identify the most suitable and effective conditions for process. Simulation results of the proposed metal oxide were compared on the basis of methane conversion and syngas purity. Relevantly, cerium-based oxide was found to be selective in syngas production even when CO₂ was added to the reforming reactor.

After the required thermodynamic validation, a fixed bed reactor on lab scale was specifically designed and fabricated, and cerium oxide oxygen carrier characterized by Thermogravimetric analysis.

Thermodynamic results and experimental tests proved the solid/gas chemical reaction takes place with appreciable conversions, and they also demonstrated the stability of the oxygen carrier redox properties during several cycles, thus confirming the feasibility of this new process.

1. Introduction

Despite all efforts to counter climate change, greenhouse gases emissions due to anthropogenic activities still represent a serious environmental issue. The role of carbon dioxide molecule in the global warming phenomena is well known, as it is the final product of the carbon cycle upon combustion of fossil fuels, and this explains the ever-growing interest in its capture and utilization.

As reported by de Caprariis et al. (2015), one of the most investigated process for CO₂ conversion to value-added chemicals is represented by the dry reforming of methane Eq(1) to syngas, key intermediates for a variety of industrial processes such as gas to liquids conversion, H₂, ammonia and methanol production.

Nonetheless traditional DRM process suffers of severe carbon deposition, sintering of the active phase and thermodynamic limitations that negatively influence the selectivity. Indeed, when CO₂ and H₂ are in the same reactor the reverse water gas shift Eq(2) reaction may occur.

In addition, one of the main issues hindering large scale implementation of the process is given by the carbon deposition associated to methane decomposition Eq(3):



With the chemical looping technology development, DRM process is proposed to take place in two separate reactors with oxygen carrier material (OC) for the methane reforming and carbon dioxide for material regeneration (Guerrero-Caballero et al. 2018). Therefore, CO₂ and H₂ are not mixed in the same reactor and carbon does not accumulate, however the efficiency of the global process is low due to the weak oxidizing power of the CO₂. Mixed processes are inspected in order to find the balance between carbon re-oxidation, pure syngas production and high selectivity of the overall process. These processes exploit the redox properties of oxygen carrier for methane reforming Eq(4), even in presence of carbon dioxide Eq(1), and air as oxidant agent Eq(5) to rapidly regenerate the looping material avoiding carbon accumulation:

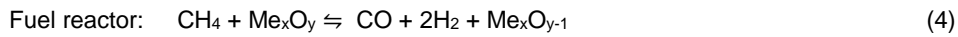

When an oxygen carrier is employed as source of oxygen the full oxidation must be considered as additional side reaction:



Kang et al. (2018) find that, beyond the already mentioned reactions Eq(2) and Eq(3), the presence of CO₂ enables the carbon re-oxidation as:



while Sun et al. (2020) show that CO₂ addition could be varied to control syngas ratio for a wide range of downstream applications, but in some extent could hinder OCs' reduction. The contribution of each reaction is strictly related to feed composition, oxygen availability and operating conditions.

2. Process simulation

2.1 General approach and process description

Process analysis was performed by means of the thermodynamic tools in Aspen Plus simulator in steady state input mode. Simulations were performed on cerium oxide system to evaluate the effect of feed composition and operative temperature on the product distribution and on syngas purity. The occurrence of the gas–solid reaction was inspected using cerium oxide as solid carrier material and methane as reactant. The simulations were setup with an optional stream class, called MIXCISLD, for the introduction of vapor components and conventional solids. The Gibbs reactor was selected to perform the simulations and results were obtained employing the Gibbs minimization energy method, in combination with the ideal gas law for the description of the gaseous phase. In all the simulations the based case reference was set in isothermal condition at atmospheric pressure and the heat duty was obtained through the energy balance.

Such an approach does not need input information such as reaction stoichiometry, indeed the reactions are not specified by the user, while all possible reactants and products are. For each possible set of reactions, the simulator exploits the specifications given to evaluate the Gibbs free energy and when a minimum of this function is reached, it determines the equilibrium composition of the gaseous phase.

It should also be noted that in this approach the solid reactant activity is equal to 1 and the species must be considered in equilibrium in the gaseous phase only.

2.2 Effect of operating parameters

First simulation was carried out selecting a stoichiometric oxygen carrier (CeO₂) to methane ratio and varying the temperature between 700 °C and 950 °C, at atmospheric pressure.

As shown in Figure 1a, at temperatures lower than 900 °C the off gas contains almost hydrogen only, most likely formed upon methane decomposition Eq(3), while in range between 700 and 900 °C the H₂/CO ratio starts to decrease up to reach the maximum theoretical value for the partial oxidation reaction Eq(4) at 900 °C.

Above 900 °C, syngas ratio and products composition seem to have reached a plateau, and values are basically independent of the temperature.

Furthermore, the selectivity towards syngas is high, while no footprint of combustion products is observed.

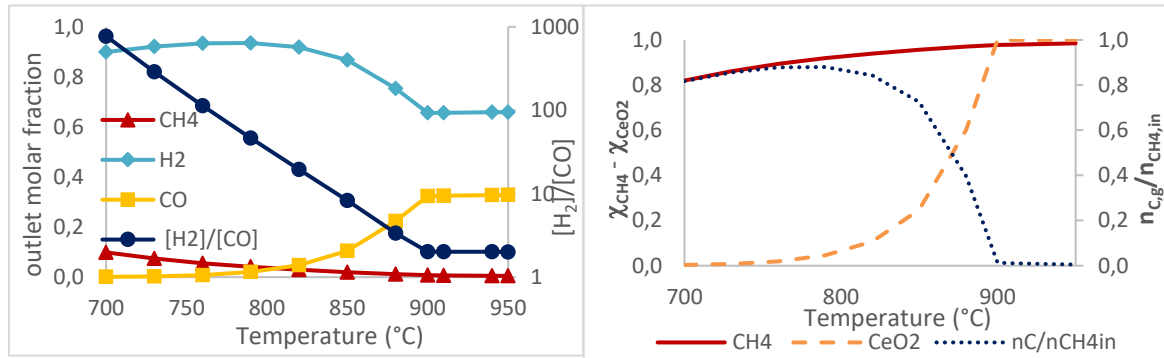

Figure 1: a) Reaction outlet composition of the gas phase at various process temperatures, using CeO₂/CH₄ in stoichiometric ratio, calculated by process simulation analysis; b) effects on conversion and carbon extent in the range 700-950 °C

The results are analysed also in terms of reactants conversion (χ_{CH_4} and χ_{CeO_2}) and carbon deposition extent ($n_{C,g}/n_{CH_4,in}$) in the Figure 1b. As one can see, an almost complete conversion for CH₄ is obtained, accompanied by the complete consumption of the metal oxide carrier, which has turned in a lower oxidation state in the Ce₂O₃ form. In addition, the operative temperature of 900 °C seems to reduce also the issue related to the carbon deposition, indeed the carbon to initial methane ratio is very close to zero.

In the following simulation the operative temperature was kept constant and equal to 900 °C while the composition was changed to evaluate the effect of carbon dioxide addition. The main parameters investigated are reported in Table 1.

Table 1: Simulation results of methane and Cerium oxide conversion and carbon black formation for different feed compositions at 900 °C and 1 atm.

	case (a) CH ₄ :CeO ₂ (1:2)	case (b) CH ₄ : CeO ₂ (2:2)	case (c) CH ₄ : CeO ₂ : CO ₂ (1:2:1)	case (d) CH ₄ : CeO ₂ : CO ₂ (2:2:2)
χ_{CH_4}	97.8	97.4	98.4	98.4
χ_{CeO_2}	100	100	0	0
$n_{C,g}/n_{CH_4}$	0.013	0.49	0.05	0.05

The CO₂ addition has a significant impact on oxygen carrier conversion, hence the effect of temperature on the process performances was inspected aiming to determine the temperature for total reduction of the carrier. The temperature was found to be equal to 910 °C when the [O]/[CH₄] ratio is equal to 0.25 and the CO₂ fraction is comprised between 0 and 0.33.

The effect of CO₂/CH₄ molar ratio on reactants conversion and carbon black formation was studied at 910 °C and the results showed in the Figure 2. As one can see, there is an optimal ratio (where y_{CO₂}=0,43), which minimizes carbon deposition per mol of CH₄ feed, and ensures high value of conversion for both the reactants as well.

Interestingly, Figure 2 shows that a large excess of carbon dioxide (y_{CO₂}=0.5) hinders the conversion of CeO₂, which falls to zero. This can be attributed to the occurring of the dry reforming reaction, which is favoured in such condition of temperature and CO₂ concentration, as supported by the syngas ratio (H₂/CO) obtained, which corresponds to the expected value for dry reforming reaction.

Overall, the carbon dioxide amount does not affect CH₄ conversion, although it has a strong influence on solid carrier material behaviour. Mass balance was calculated taking into account the composition results provided by the simulation and it was found in accordance with the made assumptions.

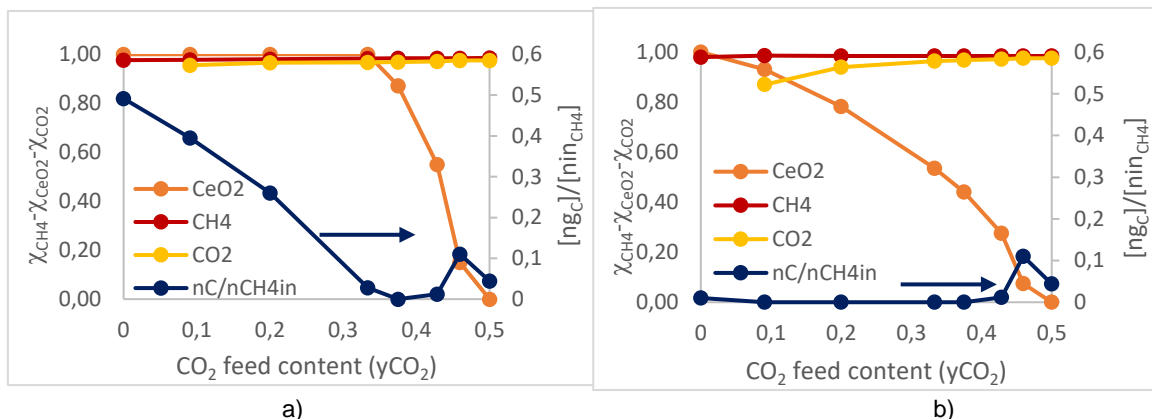

Figure 2: Effects of CO₂ extent on reactants conversion and carbon black formation in the feed stream with a [O]/[CH₄] ratio of a) 0.25 and b) 0.5. Data calculated at 910 °C and 1 atm from Aspen Plus process simulator.

3. Experimental section

3.1 Material preparation

Commercial cerium oxide powders (Pickem, purity 99.9 %) were pelletised in a hydraulic press (8,5 MTons) and then sieved to the desired size fraction of 0,595-0,841 mm. The particles were calcinated with a heating rate of 3 °C/min, left in isothermal condition at 800 °C for 1 h, then cooled to room temperature.

3.2 Experimental set up and procedure

The test rig (the layout is illustrated in Figure 3) consists of a stainless steel (AISI 316) fixed bed reactor with an inner diameter of (OD 10 mm) and a length of 180 mm. The reactor is enclosed in a tubular furnace which allow to keep a constant temperature. A K-type thermocouple is located along the reactor to measure the bed (internal) temperature. An external layer of quartz wool is applied as insulation material to avoid heat loss.

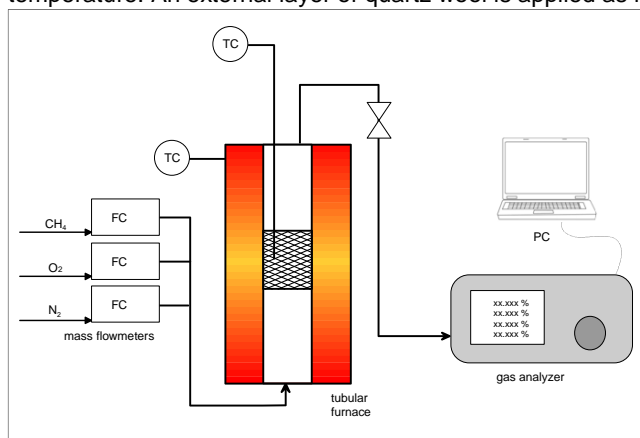

Figure 3: Schematic diagram of the experimental rig

The feed flow rate and composition are controlled by Bronkhorst mass flowmeters, while the outlet gases are analyzed continuously by means of an online analyzer (GEIT 3100 R Syngas) equipped with a thermal conductivity detector (TCD), an infrared detector (NDIR) and an electrochemical oxygen sensor.

The apparatus was used to conduct preliminary experimental test. Particularly it was employed first to evaluate cerium-based oxygen carrier activity for the methane partial oxidation reaction and then employed in cyclic mode switching gases atmosphere from reductant to oxidant in order to inspect the robustness of the process and to evaluate the conditions for material regeneration.

In a typical experiment, the reactor was loaded with 7 g of cerium oxide oxygen carrier prepared as previously described and employed without any further treatment. The sample was heated up to 900 °C with a heating rate of 30 °C/min at atmospheric pressure.

As the system reached the set point temperature, the carrier material was reduced in CH₄ (10% in N₂, 0.455 L/min) for 1 h, purged in N₂ (1 L/min) for few minutes, and eventually regenerated with synthetic air (with 21% O₂ in N₂, 0.500 L/min) for 5 minutes. The composition of the gases evolved during the reaction was analyzed continuously and evaluated for one redox cycle.

3.3 Thermogravimetric characterization

The redox performance of the proposed oxygen carrier was preliminary investigated by means of a thermogravimetric analyser (NETZSCH STA 449 C). The stability in air was controlled up to 900 °C, subsequently the extent of oxygen carrier's reducibility was monitored in isothermal condition at 900 °C as shown in Figure 4.

Around 100 mg of oxygen carrier was loaded in a Al₂O₃ crucible, and the TG chamber was heated in air up to 900 °C with rate of 30 °C/min, as the set point temperature was reached, the system was kept in air for additional 30 minutes and then a mixture of 4 % CH₄ in Ar was send to the sample for 60 minutes at gas flow rate of 180 mL/min. After the reduction step the sample was cooled at room temperature under the same reductant atmosphere with a heating rate of 30 °C/min and a gas flow rate of 180 mL/min.

The weight loss was due to the reduction of CeO₂ to Ce₂O₃ (cerium oxide in 3+ oxidation state), with the release of ¼ of O₂ moles per mole of CeO₂ Eq(5) and an average rate of O₂ release equal to 9,3e-06 nL / s*g carrier.

The increased weight in the cooling step was instead identified as carbon deposition due to the oxygen deficiency as the oxide turns to a lower oxidation state in methane atmosphere.

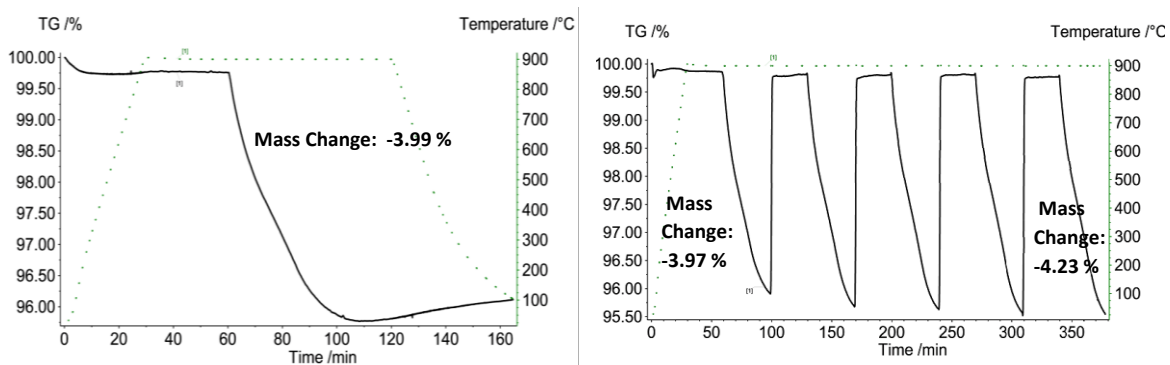

Figure4: thermogravimetric analysis of ceria, a) weight loss during a single reduction stage b) subsequent weight loss/gain in 4 cycles of reduction/oxidation

The mass change was also evaluated isothermally at 900 °C as a function of time for 4 consecutive redox cycles in order to inspect the extent of regeneration of the carrier material and rule out any possible loss in performances. As one can see in Figure 3.b, indeed, the cerium oxide can be easily regenerated upon returning to oxidant conditions (air). The analysis was carried out in the same condition of temperature while the time was decreased from 60 to 40 minutes since previous TG analysis showed that the weight loss occurs faster.

In the cyclic tests the reductant step was carried out in 4% CH₄/Ar in 40 minutes with a gas flow rate of 180 mL/min while the oxidation step in air with a flow rate of 100 mL/min for 30 minutes.

3.4 Data evaluation and results

Figure 5 reports the obtained molar fraction of the gas stream that exits the fixed bed reaction as a function of time, and such data may be used to evaluate process performances H₂/CO molar ratio, syngas purity (with respect to undesired combustion products) and even reactant conversion. As described above, the experimental procedure consists in three subsequent steps that may be recognized in Figure 5, namely carrier reduction (CH₄ in the feed), N₂ purge, carrier oxidation (synthetic air).

The reduction has been extended until no consumption of further CH₄ was observed in the online gas analyzer (1) while the oxidation has been stopped when the volumetric fraction of recorded oxygen turned to the set point value of 0.21 (3), indicating that no more oxygen was consumed by the material. The time of the intermediate step (2) corresponds to the one required for the complete removal of all the components in the reactor.

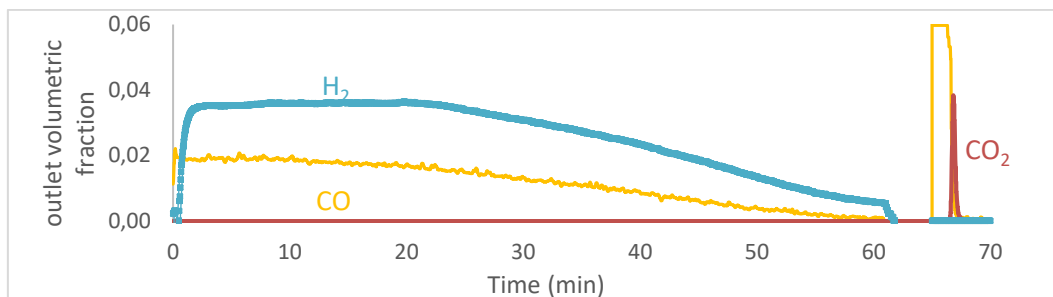

Figure 4: volumetric fraction of the off gases as a function of time during (1) the reductant in CH₄ 10% (2) purge in N₂, (3) oxidation in synthetic air ($y_{O_2}=0.21$)

During the reduction step, no carbon dioxide was detected in the products stream, while it can be observed in the oxidation step, indicating both a preferential formation of syngas to the respect of products of combustion and the contamination of carbon on the oxygen carrier surface. Indeed, during the process once the availability of oxygen decreases, the thermolysis of methane may occur Eq(3).

The carbon formed in this phase, is then reoxidizes to CO and CO₂ in presence of gaseous oxygen in the oxidation stage Eq(5).

The time evolution of the gas molar fraction of the outlet stream allows the determination of the H₂/CO ratio of the produced syngas. Interestingly, at short times, such ratio falls very close to the theoretical value for partial oxidation of methane, and it increases up to 2,5 at longer times, suggesting thermolysis takes place.

4. Conclusions

The present work demonstrates that cerium oxide can be considered a promising looping carrier material in a novel process for methane conversion to syngas. Indeed, even if the commercial material shows lower activity, it also shows quite high selectivity towards syngas in the respect to products of combustion.

Thermodynamic simulations carried out in the ideal Gibbs reactor (at the thermodynamic equilibrium) were used to identify the more suitable conditions for process. This study evidenced 900-910 °C as the ideal temperature range for the reforming process depending on the feed composition. It also proved that a molar fraction of carbon dioxide in the feed stream containing CO₂ not exceeding 0.43 can provide carbon dioxide reutilization in an extent of 97 % while minimizing carbon deposition.

From the experimental point of view, the carrier material was inspected by thermogravimetric analysis in the condition selected through simulation analysis. The analysis confirmed 900°C as suitable temperature for the cerium oxide reforming, indeed the mass loss associated to the release of oxygen in the reduction stage is sufficiently similar to the theoretical (4% vs 4.7%). Material regeneration was found to occur even at room temperature and with a very high rate for 4 consecutive cycles.

Experiments in the fixed bed reactor at 900 °C showed an off gas with high content of syngas with respect to (undesired) combustion products, as only traces of CO₂ were detected in the online analyser.

Further experiments in the fixed-bed reactor will include carbon dioxide as co-reagent with methane thus allowing to get information on the cerium-oxide potentiality even in the reuse of CO₂.

Synthetic cerium oxide will be also fabricated to evaluate the influence of structural modification on the reactivity for the proposed process.

References

- De Caprariis B., De Filippis P., Petruolo A., Scarsella M., 2015, Methane Dry Reforming over Nickel Perovskite Catalysts, *Chemical Engineering Transactions*, 43, 991-996.
- Guerrero-Caballero J., Kane T., Haidar N., Jalowiecki-Duhamel L., Löfberg A., 2019, Ni,Co,Fe supported on Ceria and Zr doped Ceria as oxygen carriers for chemical looping dry reforming of methane, *Catalysis Today*, 333, 251-258.
- Kang D., Lim H.S., Lee M., Lee J.W., 2018, Syngas production on a Ni-enhanced Fe₂O₃/Al₂O₃ oxygen carrier via chemical looping partial oxidation with dry reforming of methane, *Applied Energy*, 211, 174-186.
- Sun Z., Lua D.J., Symonds R.T., Hughes R.W., 2020, Chemical looping reforming of CH₄ in the presence of CO₂ using ilmenite ore and NiO-modified ilmenite ore oxygen carriers, *Chemical Engineering Journal*, 401, 123481.