

# Diluted Bioethanol Solutions for the Production of Hydrogen and Ethylene

Gianguido Ramis<sup>a\*</sup>, Ilenia Rossetti<sup>b</sup>, Antonio Tripodi<sup>b</sup>, Matteo Compagnoni<sup>b</sup>

<sup>a</sup> Dip. Ing. Chimica, Civile ed Ambientale, Università degli Studi di Genova and INSTM Unit Genova, Genoa, Italy

<sup>b</sup> Dip. Chimica, Università degli Studi di Milano and INSTM Unit Milano-Università, Milan, Italy  
[gianguidoramis@unige.it](mailto:gianguidoramis@unige.it)

The possibility to use diluted bioethanol solutions is investigated. Ethanol purification and anhydrification impacts for 50-80 % of its production cost, but it is compulsory only when bioethanol is used for gasoline blending. Bioethanol can be converted to hydrogen, an increasingly important energy vector, through the steam reforming process. In this case, water must be fed at least in stoichiometric ratio (*i.e.* 3:1 mol/mol). Nevertheless, higher water/ethanol ratio is usually suggested to achieve CO conversion through the water gas shift reaction and to prevent catalyst deactivation by coke deposition.

In this light, the use of dehydrated ethanol is detrimental for process efficiency and cost sustainability, opening the way to the use of more diluted bioethanol solutions. The effect of bioethanol purity and concentration is here investigated both experimentally and through process simulation with Aspen Plus<sup>®</sup>.

Two solutions of second generation bioethanol, kindly supplied by Mossi&Ghisolfi, with ethanol concentration 90 and 50 wt% and obtained after different separation processes (distillation and flash, respectively) were compared with pure ethanol 99.9 vol%. We have concluded that, if the steam reforming process is carried out at temperatures above 600 °C, all the feeds brought to the same results. If temperature is lowered to 500 °C (with the aim of process intensification), different results have been obtained depending on catalyst formulation, depending on materials resistance towards some possibly poisoning compounds contained in the 50 wt% feed.

The same approach was followed by considering the possibility to produce bioethylene through the dehydration of bioethanol. At first, we carried out a thermodynamic study to understand the effect on ethanol conversion and products distribution of increasing water amount in the feed. We observed that the equilibrium conversion is shifted by ca. 50 °C towards higher temperature when using 50 wt% ethanol rather than the pure one. Furthermore, we simulated a possible process configuration accounting for heat recovery, in order to heat up and vaporize the inlet water thanks to the heat recovery with the products stream. Finally, we compared different catalyst formulations, mainly constituted by acidic BEA zeolites, in case added with small Ni amounts to improve selectivity to ethylene. 100 % conversion of diluted ethanol and 99 % selectivity to ethylene have been achieved under the best reaction conditions. Also in this case bioethanol solutions with different purity have been compared with negligible effect on the results.

## 1. Introduction

Bioethanol is produced through fermentation of vegetable raw materials according to various processes. Generalizing, it is possible to identify processes that lead to first-generation or second-generation bioethanol. The first group includes those processes that use raw materials used for food or feed, such as corn, prevalent in the USA, or sugar cane, the typical case of Brazil. Ethanol production in the US increased from ca. 175 Mgal in 1980 to 14 Ggal in 2015 ([ethanolrfa.org/how-ethanol-is-made/](http://ethanolrfa.org/how-ethanol-is-made/)). Second generation bioethanol can be instead produced by fermentation of lignocellulosic or waste products of agricultural processing. An example of this is the Proesa<sup>®</sup> process developed recently by Biochemtex (Mossi and Ghisolfi Group). This technology was demonstrated in the plant of Crescentino (Italy), 60,000 t/y, competitive today with a cost of oil of 70 \$ per barrel, and allowing to obtain 1 ton of bioethanol with 4-5 tons of dry biomass, with a final cost 0.30 Euro/L. It was also licenced in Brasil for 80 ML/y ethanol production. The same technology was then associated with the

dehydration of bioethanol to bio-ethylene in Taiwan and characterized by low CAPEX and OPEX thanks to the integration up- and down-stream between the production of ethanol and its dehydration.

The crude bioethanol consists of a beer, with ethanol concentration up to 8 vol%, which must be purified. Ethanol is separated from the fermentation residue in a first column. The bottom product, mainly constituted by lignin, is valorised as fuel. The top ethanol stream is then dehydrated to obtain a pure product (99 vol% or more). Bioethanol is currently used as solvent for the chemical industry or blended with gasoline, in order to increase the share of renewables in the fuels pool. For such uses deep anhydrification is compulsory. Nevertheless, different applications are emerging in the so called biorefinery field, which require water addition to ethanol. A first example is constituted by hydrogen production by steam reforming of bioethanol, requiring at least a stoichiometric 3:1 mol/mol water/ethanol ratio. Another example is the production of ethylene through heterogeneous catalytic dehydration of ethanol. In this case, the advantage of water addition is less intuitive from the thermodynamics point of view, but is suggested to improve catalyst durability. Indeed, the acidic sites active for ethanol dehydration may favour its consecutive polymerisation on the catalyst with consequent deactivation. Thus, steam is often added to prevent coking. Therefore, for both these applications the use of anhydrous bioethanol is not necessary and the possibility to adopt less purified solutions would represent a considerable advantage from the economic point of view, since ethanol dehydration impacts for 50-80% on its production costs.

Therefore, in this work we evaluated the possibility to use diluted bioethanol solutions for both ethanol steam reforming and ethanol dehydration to ethylene. At first we summarise some process-related considerations in order to check if there can be a real advantage in the use of diluted, less purified, bioethanol streams. Furthermore, we present some experimental data for both applications which make use of second generation bioethanol with different purity.

## 2. Process considerations

### 2.1 Ethanol dehydration process

The ethanol-water solution shows a minimum azeotrope for ethanol ca. 96 vol%. It is, therefore, impossible to obtain pure ethanol by simple distillation in a single stage. Different purification processes were proposed, characterized by variable energy efficiency and, consequently, by different cost. Typically, they include two processes to achieve concentrations up to the azeotrope and further dehydration. For instance, the concentration section can be divided into columns working at different pressures, so that the reboiler of the low pressure column may be thermally coupled with the condenser of the high pressure one (Lynn & Hanson, 1986). As for the dehydration step, different concepts have been proposed: a) heterogeneous azeotropic distillation with a third component, capable of forming a heterogeneous azeotrope with water (for example benzene, toluene, n-pentane or cyclohexane); b) extractive distillation using a third component to change the relative volatility of ethanol / water (e.g glycols); c) distillation at various pressures. The latter takes advantage of the change in azeotrope composition with pressure (Black, 1980; Lee and Pahl, 1985; Lynn and Hanson, 1986). Therefore, the dehydration can be carried out under vacuum in the absence of an azeotrope or using two columns, connected in series, with increasing pressure (Pressure-Swing), with a third component to facilitate the separation.

A comparative analysis of azeotropic, extractive distillation and adsorption for ethanol dehydration was carried out by Bastidas et al., on a base case of 300 m<sup>3</sup>/d of anhydrous ethanol and including a preliminary costs analysis (Bastidas et al., 2010).

According to our previous investigation (Rossetti et al., 2015a), different purification strategies were compared, in order to obtain bioethanol solutions with proper concentration to feed a steam reforming unit. In particular, the stoichiometric water/ethanol ratio 3:1 (mol/mol), corresponding to a ca. 50 wt% solution, can be conveniently prepared by flash separation from the fermentation broth. Sometimes even more diluted solutions are desirable to feed steam reforming units. Excess water can indeed favour thermodynamically the water gas shift reaction (leading to higher hydrogen yield and purity) and, meanwhile, it may prevent coking. Different water/ethanol ratios have been conveniently explored to simulate the electrical and thermal output of a 5 kW<sub>electrical</sub> + 5 kW<sub>thermal</sub> cogeneration unit (Rossetti et al., 2015b,c). The best plant efficiency was achieved with even more diluted feed, i.e. with water/ethanol = 11:1 mol/mol. Therefore, it is convenient to explore in more detail the most convenient separation strategies in this low concentration ratio.

Flash separation requires low duty to achieve relatively low water/ethanol solutions. However, low ethanol recovery is allowed in this case, as better detailed in (Rossetti et al., 2015a). When more diluted solutions are desired flash duty increases. As alternative strategy, feed splitting can be characterised by lower duty: the bioethanol broth can be only partially distilled in a 10-stage column, the remaining portion bypassing the distillation column to virtually achieve any desired bioethanol concentration.

Figure 1 summarises the duty required in both cases, depending on the desired water/ethanol ratio, starting from a fermentation broth containing 4 mol% of ethanol. The simulation was carried out using the Aspen Plus® simulator process, using the thermodynamic package-Predictive Soave-Redlich-Kwong (PSRK) (Rossetti et al., 2015a).

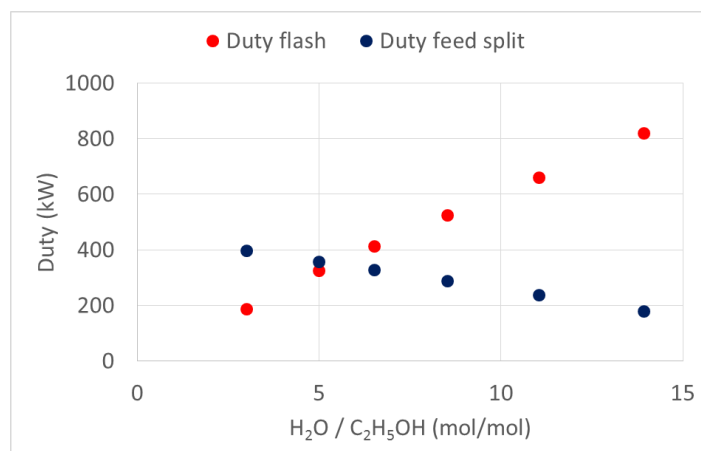

Figure 1: Duty (kW) to the flash unit or to the reboiler of the distillation unit in the case of feed split, as a function of the target water/ethanol ratio.

## 2.2 Process simulation of a heat and power cogeneration unit

A cogeneration unit with residential size has been simulated by our group by means of the Aspen Plus process simulator. The system is thoroughly described elsewhere (Rossetti et al., 2015a,c). Briefly, it is composed of an ethanol steam reformer, followed by high and low temperature water gas shift reactors and a methanator to achieve sufficient hydrogen purity to feed a polymer electrolyte fuel cell (< 20 ppmv CO). The same reformat is used as fuel for a burner to thermally sustain the endothermal reformer. The flowsheet is sketched in Figure 2. The process has been simulated by considering a catalyst amount of 1, 3 and 5.5 kg, at variable temperature and water/ethanol ratio. We here highlight the dependence of the electrical and thermal power output from the water/ethanol ratio in the feed, as summarised in Figure 3.

Increasing the water/ethanol ratio in the feed monotonously improved hydrogen productivity due to favourable thermodynamic equilibria. The effect of water/ethanol ratio on the amount of hydrogen allowed to the fuel cell and therefore on power output is less trivial to describe. On one hand, additional water in the feed must be vaporised, so requiring additional heat input to the reformer. Therefore, of the more reformat produced, a bigger fraction has to be used as fuel when increasing the water/ethanol ratio in the feed, leaving a smaller fraction to feed the fuel cell. Nevertheless, the exothermal water gas shift reaction, partially occurring already in the steam reformer, is favoured by excess water, so that the reactor is partly sustained in this way, requiring lower reformat as fuel. As a result, higher electrical power output can be achieved with intermediate water/ethanol ratio. The total power output, including thermal energy recovery, again monotonously increased with feed dilution, because excess water provided in the feed can be recovered from the plant in the form of hot water (65-80 °C), which can be valorised in the cogeneration plant. Similar results were achieved when varying catalyst mass or reactor temperature, although temperature and water/ethanol ratio cannot be independently modified, as recently demonstrated (Tripodi et al., 2016; Compagnoni et al., 2017).

## 2.3 Process simulation of an ethanol dehydration reactor

Water addition can be apparently not indicated for ethanol dehydration to ethylene. Thermodynamic calculations indicate the need to operate at 50°C higher temperature (from 200 to 250°C) to achieve full ethanol conversion when cofeeding water/ethanol = 3:1 mol/mol instead of pure ethanol.

Nevertheless, steam addition is usually practiced to prevent catalyst deactivation by coking. Furthermore, the addition of water in the feed requires additional heat input for its vaporisation. Most of the energy required can be obtained from the product stream, by condensing back excess steam (the amount originally fed plus the amount produced through dehydration) in a heat recovery exchanger as exemplified in Figure 4. The proposed flowsheet, compiled in Aspen Plus, is composed of a stoichiometric reactor accomplishing the full ethanol dehydration to ethylene according to the reaction  $C_2H_5OH \rightarrow C_2H_4 + H_2O$ . We selected as thermodynamic package the NRTL one to compute non ideality in liquid phase and the SRK model for the

vapour phase. The heat required by the endothermic reaction is computed as reactor duty in Table 1. Feed preheating and vaporisation is obtained partially through a heat recovery exchanger, valorising the condensation heat of excess steam. The feed is then brought to the desired temperature by means of a heater. The net heat input supplied by the heater (Table 1) is minor with respect to the duty for the reactor, it is substantially independent from the reaction temperature and increases with the water/ethanol amount. Increasing reaction temperature would of course imply preheating the feed at higher temperature, but hotter products would be available, increasing the heat transferred in the heat recovery exchanger. A really cheap diluted bioethanol solution as feed can justify this moderate additional duty to the heater.

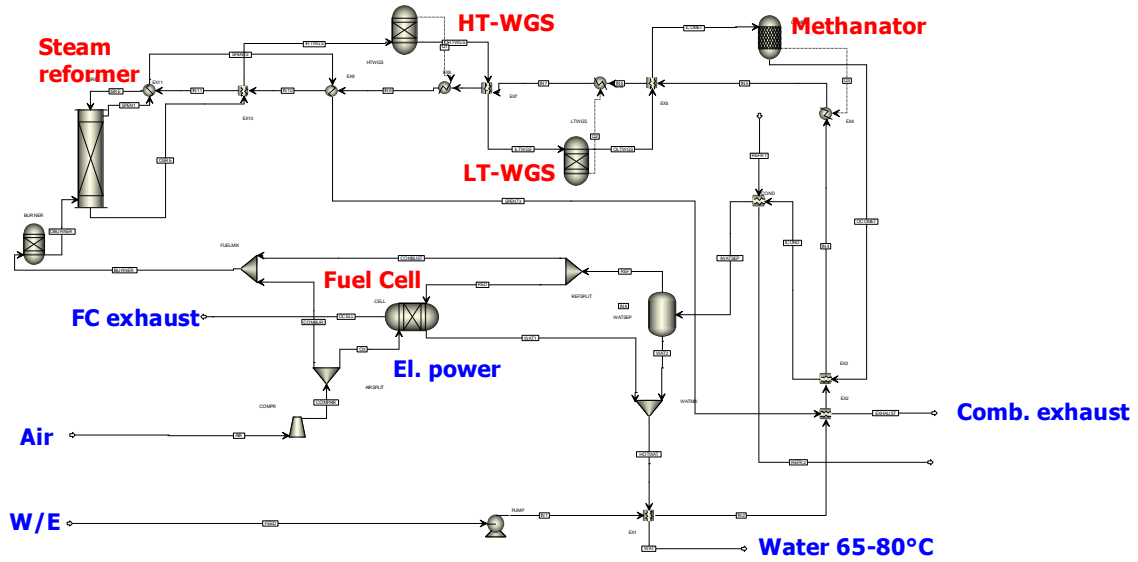

Figure 2: Flowsheet of a heat and power generation unit fed with diluted bioethanol.

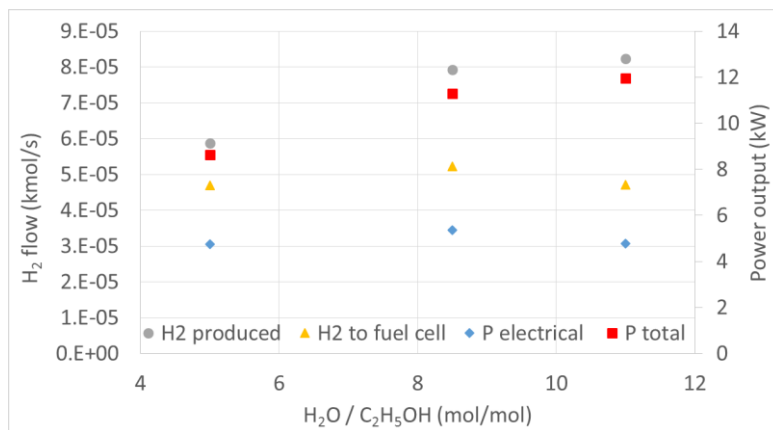

Figure 3: H<sub>2</sub> productivity and H<sub>2</sub> fed to the fuel cell; electrical and total power output as a function of the water/ethanol ratio in the feed. Catalyst mass 3 kg, reformer average temperature 635 °C.

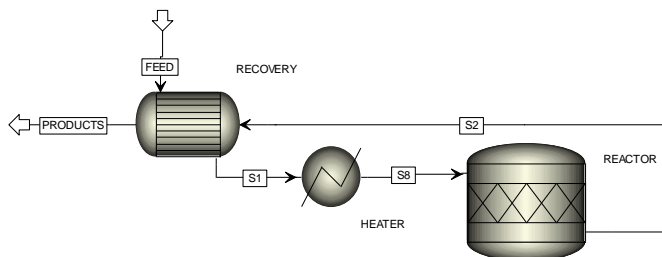

Figure 4: Heat recovery scheme for an ethylene dehydration reactor.

Table 1: Duty to the equipment reported in Figure 4 at variable reaction temperature and water/ethanol (W/E) ratio in the feed.

T reactor (°C)	W / E (mol/mol)	Duty reactor (kW)	Duty heater (kW)	Internal heat recovery (kW)
300	0	13.0	2.2	16.1
	3	13.0	4.6	58.7
	5.5	13.0	6.5	94.0
	11	12.9	11.0	171.4
500	0	12.9	3.2	21.6
	3	12.9	3.3	72.6
	5.5	12.9	4.6	113.8
	11	12.8	7.5	204.1

### 3. Testing with second generation bioethanol with different purity

Based on the previously reported considerations, the use of diluted bioethanol solutions appears feasible. Different, less expensive purification strategies can be coupled to the two selected examples in order to develop an integrated process economically sustainable. Nevertheless some doubts may remain on the real equivalence of a poorly dehydrated sample with respect to absolute ethanol. Indeed, rectification eliminates excess water, but also heavier alcohols and residua of the fermentation process. Therefore, to quantify the required heat input for the process the mixture is typically approximated with a binary ethanol + water one. However, the starting beer is a heavily heterogeneous mixture, including salts, higher alcohols, possible acidic molecules, etc., which may be found in a poorly purified fraction, e.g. after flash. Such impurities may cause catalyst deactivation.

To check this point we have compared the performance of a second generation bioethanol solution, characterised by different purity. A first sample was preliminarily separated in flash drum, leading to a 50 wt% mixture (water/ethanol ca. 3:1 mol/mol, BE50). The other was rectified to reach a 90 wt% purity (BE90).

A preliminary analysis evidenced the presence of some compounds of concern in both solutions. The amount of higher alcohols was ca. 0.15 wt% for BE50, negligible for BE90. These compounds may give rise to higher olefins, which may contribute to easier catalyst coking. The conductivity of BE50 was one order of magnitude higher than that of BE90, indicating a possibly higher concentration of salts. This should be taken into account during the design of the heat exchanger for the vaporisation of the feed, which may be subject to the formation of deposits. Finally, some sulphur containing compounds (0.3 ppm in BE90 vs. 0.7 ppm in BE50) can poison Ni loaded catalysts such as those used for ethanol steam reforming. Therefore, we concentrated particularly on the possible deactivation of steam reforming catalysts using these feedstocks.

One of our best performing catalysts (Rossetti et al., 2012; Rossetti et al., 2014), constituted by 10 wt% Ni/ZrO<sub>2</sub> + 9 wt% Na<sub>2</sub>O, was tested on a continuous benchscale micropilot plant for ethanol steam reforming. Testing was carried out at 500°C, GHSV = 2,500 h<sup>-1</sup>, W/E = 3:1 (mol/mol) using BE50 and BE90 for 100 h-on-stream, to check catalyst durability.

The results are reported in Figures 5a and 5b, corresponding to 100 % ethanol conversion. They clearly evidence that no appreciable deactivation was observed. The maximum expected hydrogen productivity, ca. 1.2 mol/min kg<sub>cat</sub> for the given reaction conditions, was achieved and maintained. The only appreciable byproduct was methane (formed by ethanol decomposition into CH<sub>4</sub> + CO + H<sub>2</sub>), whose selectivity remained ca. 10 %. No trace of acetaldehyde was observed, a byproduct often correlated to incipient deactivation of the catalyst.

Therefore, even if different purification strategies may leave some possibly noxious impurities in poorly purified samples, they practically do not affect the catalyst performance during ethanol steam reforming. Preliminary testing was also carried out on ethanol dehydration to ethylene and both BE90 and BE50 led to identical catalytic performance than absolute ethanol.

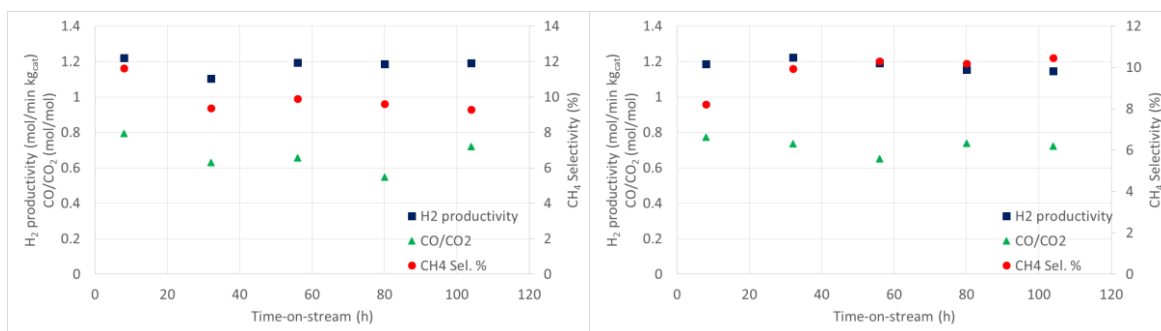

Figure 5: Ethanol steam reforming tests (5 days) using a) BE50, b) BE90.  $T = 500^{\circ}\text{C}$ ,  $W/E = 3: 1 \text{ mol/mol}$ ,  $GHSV = 2,500 \text{ h}^{-1}$ . Each point represents the average of at least 10 samplings (one each hour) every day.

a)

b)

#### 4. Conclusions

In this work we explored the possibility to use diluted bioethanol solutions for two emerging applications, *i.e.* ethanol steam reforming to produce hydrogen and ethanol dehydration to ethylene. It is possible to design less expensive strategies for ethanol purification, such as flash or feed splitting. The addition of excess water when feeding ethanol is overall sustainable for ethylene production and it may even induce improved power output in the case of a power cogeneration plant based on ethanol steam reforming and further conversion of the reformat in fuel cells. Finally, the effect of possible impurities has been experimentally checked up to 100 h-on-stream using real second generation bioethanol feed with different purity.

#### Acknowledgments

Biochemtex SpA (M&G Group, Rivalta Scrivia, Italy) is gratefully acknowledged for providing us the BE50 and BE90 samples of second generation bioethanol.

#### References

- Bastidas, P.A., Gil, I.D. & Rodriguez, G., 2010. Comparison of the main ethanol dehydration technologies through process simulation. 20th European Symposium on computer aided process engineering - ESCAPE20, pp.1–6.
- Black, C., 1980. Distillation Modeling of Ethanol Recovery and Dehydration Processes For Ethanol and Gasohol. Chemical Engineering Process, 76, pp.78–85.
- Compagnoni, M., Tripodi, A. & Rossetti, I., 2017. Parametric study and kinetic testing for ethanol steam reforming. Appl. Catal. B: Environmental, 203, pp. 899–909.
- Lee, F. & Pahl, R.H., 1985. Solvent Screening Study and Conceptual Extractive Distillation Process To Produce Anhydrous Ethanol from Fermentation Broth. Ind. Eng. Chem. Process Des. Dev., 24, pp.168–172.
- Lynn, S. & Hanson, D.N., 1986. Multieffect Extractive Distillation for Separating Aqueous Azeotropes. Ind. Eng. Chem. Process Des. Dev., 25, pp.936–941.
- Nichele, V. et al., 2014. Ni/ZrO<sub>2</sub> catalysts in ethanol steam reforming: Inhibition of coke formation by CaO-doping. Applied Catalysis B: Environmental, 150–151, pp.12–20.
- Rossetti, I. et al., 2015. H<sub>2</sub> production from bioethanol and its use in fuel-cells. Chemical Engineering Transactions, 43, pp.229–234.
- Rossetti, I. et al., 2012. Ni/SiO<sub>2</sub> and Ni/ZrO<sub>2</sub> catalysts for the steam reforming of ethanol. Applied Catalysis B: Environmental, 117–118, pp.384–396.
- Rossetti, I., Compagnoni, M. & Torli, M., 2015a. Process simulation and optimisation of H<sub>2</sub> production from ethanol steam reforming and its use in fuel cells. 1. Thermodynamic and kinetic analysis. Chemical Engineering Journal, 281, pp.1024–1035.
- Rossetti, I., Compagnoni, M. & Torli, M., 2015b. Process simulation and optimization of H<sub>2</sub> production from ethanol steam reforming and its use in fuel cells. 2. Process analysis and optimization. Chemical Engineering Journal, 281, pp.1036–1044.
- Tripodi, A., Compagnoni, M. & Rossetti, I., 2016. Kinetic modelling and reactor simulation for ethanol steam reforming. ChemCatChem, 8, pp.3804–3813.