



## Exergoeconomic Analysis of a 30 kW Micro Turbine Cogeneration System Using Hysys and Matlab

Ismael A. Orellanos Camargo<sup>\*a</sup>, Guillermo E. Valencia Ochoa<sup>a</sup>, Javier E. Rendón Lafaurie<sup>a</sup>, Marisol Osorio Cardenas<sup>b</sup>

<sup>a</sup>Faculty of Mechanical Engineering, Universidad del Atlántico, Km 7 Via Puerto, Barranquilla, Colombia

<sup>b</sup>Faculty of Engineering, Universidad Pontificia Bolivariana, Circular 1 #70-01, Los Laureles, Medellín, Antioquia  
[uaiorellanos@hotmail.com](mailto:uaiorellanos@hotmail.com)

Cogeneration systems with the use of microturbines are appropriate for the use of low quality energy that is normally wasted in conventional power generation systems technologies. The aim of this research is perform a thermodynamic, exergy and exergoeconomic assessment of a system of combined heat and electrical power using a Capstone 30 kW microturbine, considering first and second law efficiencies and the total cost rates of the system. This analysis is done through an interface designed that linked HYSYS with Matlab which allow the evaluation of these three parameters in a simplified way, this interface is validated by the simulation of other cogeneration system proposed by Adrian Bejan and George Tsatsaron. The results show that the highest rate of destruction is in the combustion chamber, then the compressor and heat recovery respectively. In the analysis the highest exergoeconomic costs is taken into flow from the compressor outlet, it is because all the exergy supplied to this flow is given by the mechanical power of the compressor. To evaluate the effect of varying the design parameters of this system functions in the three objectives functions, a parametric study is conducted. The results reveal that by increasing the compression ratio, the compressor and gas micro turbine efficiency improve thermodynamic system performance, however, increasing the compression ratio of the compressor increases the rate of system costs per unit time, on the other hand, the compressor and gas micro turbine efficiency and the outlet temperature of the preheater will be useful for the system in thermal and exergoeconomic terms.

### Introduction

The latest advances in the area of electricity generation, lie in improving efficiency (Cengel and Boles, 2011), it has been determined that in thermal power generation processes, the temperature of the exhaust gases of these systems are around 550 K, where approximately 30 % of this energy is wasted, which justifies the need to implement a system able to use this potential, a system which recover the heat from exhaust gases in an industrial process, this process is known as cogeneration (Hosseini and Wahid, 2014).

Cogeneration allows the production of more than one form of energy from the same energy source, these systems are wide used in industry where high heat and a large amount of electricity is consumed, since it covers efficiently the energy demand of different industrial processes (Cengel and Boles, 2011).

With the economic scenario affecting the domestic and international markets, industries and companies have to find ways to be more productive and reduce production costs. To make system designs really efficient, it is necessary to conduct an economic analysis of the production of electrical energy and determine the actual residual heat utilization system, which can be used to generate steam, hot water, heating and even cooling by heat absorption while introducing environmental benefits by reducing annual CO<sub>2</sub> contribution by the companies (Blankinship, 2009). In order to obtain the most out cogeneration, it is necessary to conduct a study taking into account the environment where the plant supposed to operate, equipment efficiencies, fuel consumption, its potential work, and other variables which are covered in a exergoeconomic analysis

The aim of this article is to make an assessment of the results of the case of studies provided by the interface GUI linked with Hysys created in Matlab which is adaptable to any cogeneration system, in this case a

complete analysis of the study of a microturbine Capstone 30kW has been done, this turbine comes with the whole cogeneration system within its shell, this study will be conducted with the environmental conditions of Barranquilla, Colombia in order to achieve results according to our local context. It is worthy to point out that the use of cogeneration systems with micro turbines opens the door for using the cogeneration technology in a wide range of sectors, such as the residential, breaking the barrier that limited sectors of lower energy consumption to the use of the advantages of cogeneration.

## 1. System description

The Capstone 30 kW micro turbine is a system that incorporates within a housing all the elements that are part of a system of power generation. The system includes a compressor, a boiler, combustion chamber, a turbine and a permanent magnet generator, as it was modelled in Figure.1.

Exhaust gases from the micro turbine are used as heat source used by the air heater after passing a heat exchanger (steam generator) and subsequently are discharged into the atmosphere. System data are supplied by Capstone and is summarized in Table 1.

Table 1. Data provided by Capstone C30 micro turbine

Description	Symbol	Value	Unit
Electric power of micro turbine	$W_T$	30	KW
Output temperature of micro turbine	$T_{out}$	276	°C
Room temperature	$T_{Atm}$	30	°C
Air pressure	$P_{atm}$	0,11013	MPa
Compression ratio compressor	$R_c$	3,6	—
Efficiency of combustion chamber	$n_{cc}$	0,98	—
Compressor isentropic efficiency	$n_{co}$	0,78	—
Turbine isentropic efficiency	$n_{to}$	0,83	—
Mechanical compressor efficiency	$n_{cm}$	0,995	—
Mechanical turbine efficiency	$n_{tm}$	0,995	—
Generator efficiency	$n_g$	0,96	—
Electronics efficiency	$n_e$	0,96	—
Steam demand	$\dot{m}_8$	60	Kg/h
Mass flow, exhaust gases	$\dot{m}_7$	1116	Kg/h

The following conditions are assumed in the GUI designed to simplify the thermodynamic analysis of these cogeneration systems (Steve Blankinship, 2009):(I) The turbine and compressor are mounted on a common shaft..(II) The working medium is considered an ideal gas (air), the mass of fuel is almost negligible because of the large amount of excess air in the system, (IV) The fuel input is assumed as methane and complete combustion takes place inside the camera, (V) Exergy and entropy air has a value of zero for the atmospheric pressure of 0.11013 MPa and temperature of 288 K.

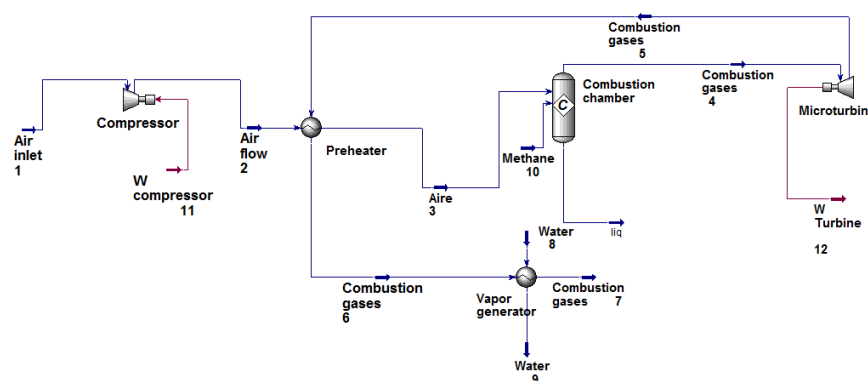

Figure 1. Cogeneration system micro turbine Capstone model in HYSYS

## 2. Thermodynamic Modelling

### 2.1 Energy Analysis

Using the Peng-Robinson in HYSYS the values of mass flow, pressure, temperature, enthalpy and entropy are obtained for each state, those values are exported in real time to the GUI in Matlab to be used for later analysis.

### 2.2 Exergy Analysis

Exergy of a system is divided into thermomechanical exergy and chemical exergy. is called thermomechanical exergy which is defined, as follows (Silveira and Tuna, 2003) :

$$E = E^{PH} + E^{KN} + E^{PT} + E^{CH} \quad (1)$$

$E^{th}$  can be divided into three components: physical exergy  $E^{PH}$ , kinetic exergy  $E^{KN}$ , potential exergy  $E^{PT}$ . The kinetic and potential exergies are ignored in this work. The physical specific exergy and chemical exergy are given by (Silveira and Tuna, 2003):

$$E^{PH} = (h - h_0) - T_0(S - S_0). \quad (2)$$

$$e^{-CH} = -RT_0 \sum x_k \ln \frac{x_k^e}{x_k} \quad (3)$$

Where  $h$ ,  $s$  and  $T$  are enthalpy, entropy and temperature, respectively. Subscript 0 is referred to the environmental conditions, In Eq (1)  $R$  represents the universal gas constant and  $x_k$  the molar fraction of the gas

### 2.3 Exergy destruction and second laws efficiency

The destruction of exergy in the components that make up a system, obeys mainly to one or more of the three main irreversibility's associated respectively with the chemical reaction, heat transfer and friction. This variable influence the exergy efficiency.

## 3. Exergoeconomic analysis : SPECO method

To determine the condition, the costs of each energy flow  $\dot{C}$  (USD \$/h) that makes up the system is used the SPECO method which through the balance of costs control volume and the use of auxiliary equations allows a matrix which gives as a result the balance cost in each flow ( $\dot{C}$ ), where  $\dot{Z}$ ,  $\dot{E}$  and  $\dot{W}$  correspond to capital cost rate of equipment, Energy flow and compressor and turbine work respectively. To estimate the value of  $\dot{Z}$  this analysis have used the simplified equations of economic calculations that only depend on prices of equipment, its shelf life and interest rate (Malinowski and Lewandowska, 2013)

Table 2. Exergoeconomic balance

Component	Exergoeconomic balance	
Air Compressor	$\dot{C}_6 + \dot{C}_8 + Z_{hrsg} = \dot{C}_7 + \dot{C}_9$ $\dot{C}_1 = 0$	
Air preheater	$\dot{C}_2 + \dot{C}_5 + \dot{Z}_{ph} = \dot{C}_3 + \dot{C}_6$	$\frac{\dot{C}_6}{\dot{E}_6} = \frac{\dot{C}_6}{\dot{E}_5}$
Combustion Chamber	$\dot{C}_3 + \dot{C}_{10} + \dot{Z}_{cc} = \dot{C}_4$	
Gas turbine	$\dot{C}_4 + \dot{Z}_{gt} = \dot{C}_5 + \dot{C}_{11} + \dot{C}_{12}$ $\dot{E}_{12} = \dot{W}_{12}$	$\frac{\dot{C}_5}{\dot{E}_5} = \frac{\dot{C}_4}{\dot{E}_4}$ $\frac{\dot{C}_{11}}{\dot{E}_{11}} = \frac{\dot{C}_{12}}{\dot{E}_{12}}$
Steam generator	$\dot{C}_6 + \dot{C}_8 + Z_{hrsg} = \dot{C}_7 + \dot{C}_9$ $\dot{C}_8 = 0$	$\frac{\dot{C}_7}{\dot{E}_7} = \frac{\dot{C}_6}{\dot{E}_6}$

#### 4. Exergoeconomic analysis of cogeneration system 30kw Capstone Microturbine through the use of the interface GUI created in Matlab supported by HYSYS energy balance

The cost data turbine micro turbine Capstone C30, are obtained from the distributor of Capstone in Colombia, Super Nova Energy Services (Bazzo et al., 2003).

The plant fuel is natural gas, price (0.0038 \$ USD / kJ) (Silveira and Tuna, 2003). In addition to the elements of a system part of this cogeneration system, it will be analysed the steam generation takes into account the collector of the heat of the gases. The plant performance is investigated in the environmental conditions of the city of Barranquilla (30 °C, 1 atm). The interest rate of the equipment is set to 10 %, total working hours in a year the system at maximum load is taken as 7200 hours. The shelf life of the plant is 20 years.

With the solution of the matrix generated with the equations displayed in table 2, it can be obtain the following costs of each energy flow  $\dot{C}$  which is the only unknown variable form the equations, for the streams in the micro turbine Capstone 30 Kw.

Table 3. Exergoeconomic analysis

State	$\dot{C}$ (USD \$/h)	$\dot{C}$ (USD \$/GJ)
1	0,00	0,00
2	3,60	22,40
3	5,70	20,70
4	7,80	15,30
5	3,20	15,30
6	1,20	15,30
7	0,50	15,30
8	0,00	0,00
9	0,70	33,90
10	2,20	5,80
11	3,30	17,60
12	1,60	17,60

The highest cost per unit of exergy is reached flows 2 and 9, in the flow 2 is because this flow is air outlet and all exergy is provided by mechanical power, this is of the most expensive fuel entire in the system (Bejan et al., 1996).

#### 5. Case of studies of capstone turbine 30 kW through the use of the GUI created in Matlab supported by HYSYS energy balance

A parametric analysis is carried out to evaluate the effects of varying design parameters of the cogeneration system on the first and second law efficiency of the thermodynamic and total system costs of the system per hour. The achieved results are shown in the following figures:

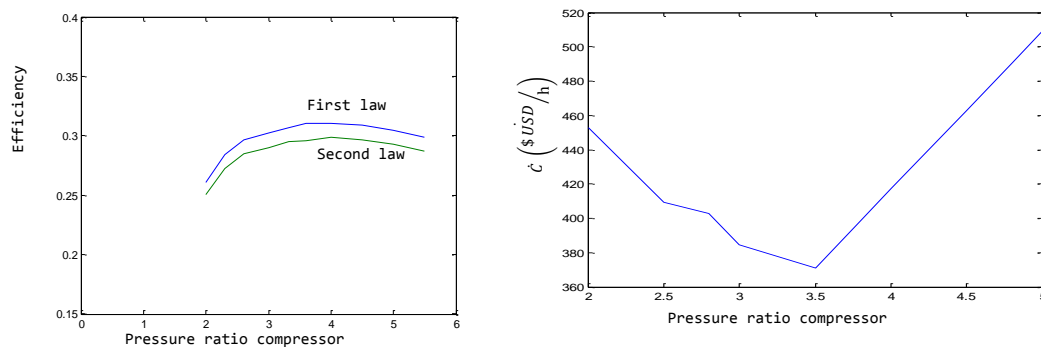

Figure 2. Compression ratio compressor: 1-5

Figure 2 left side points that the highest efficiency is reached in the first and second law curves when compressor ratio takes the value between 3.5-4, which coincides with the manufacturer's design manufacturer specification which is 3.5, this is due to the radius of compression of the compressor is inverse to the ratio of compression of the turbine, therefore if the power of one increases, the output of the other must also increase. Increasing the compression ratio to 3.5 reduces the total cost of the cogeneration system per hour from \$ 460

to \$ 370 per hour as shown in the graph in the right side in Figure 2, In addition, with the increase in the compression ratio the exergy destruction rate in the system is reduced and the fuel flow consumed is reduced, which reduces the total cost of the system. However, having a compressor ratio greater than 3.5 increased cost because generating this power in the compressor, is more expensive than the cost reduction by exergy destruction.

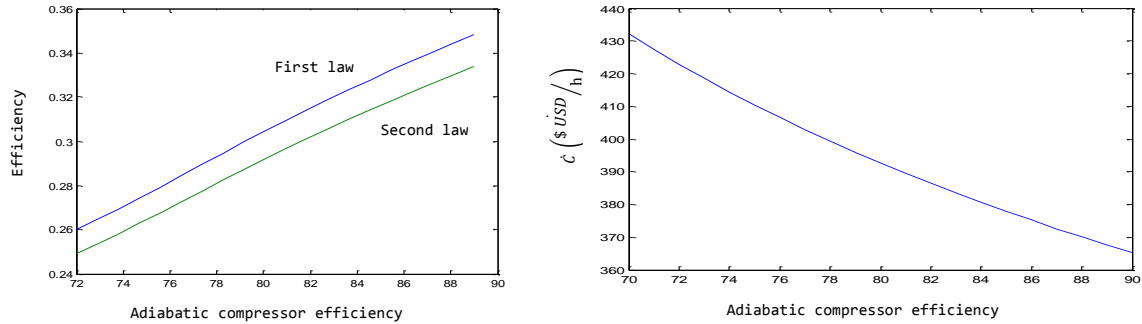

Figure 3. Adiabatic compressor efficiency: 72- 89%

As can be seen in the Figure 3 left side, the increase in isentropic efficiency leads to an increase in the efficiency of the first and second law of the thermodynamics cycle. With the increase in the isentropic efficiency of the air compressor, the power consumption of the compressor will be reduced which results in a respective reduction in the power of the gas turbine, assuming that the required power of the network is constant. As a result the fuel inlet and the air flow rate are reduced and thus the cost rate of exergy gas destruction of the gas turbine is reduced as shown in graph of the right side in Figure 3.

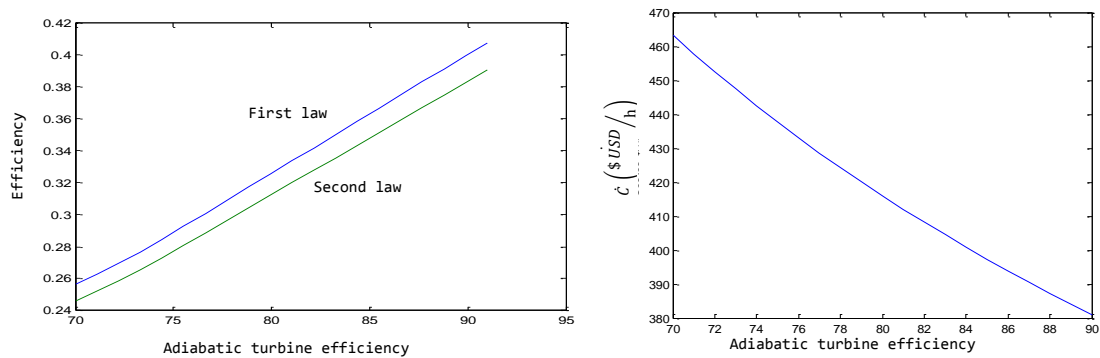

Figure 4 Adiabatic efficiency gas turbine: 70-91%

The Figure 4 left side shows that the increase of the isentropic efficiency of the gas turbine produces an increase in the efficiency of the first and second law of the thermodynamics of the system. With the increase of isentropic efficiency of the gas turbine, the rate of fuel consumption and the rate of destruction of exergy of the system are reduced, implying an increase in the efficiency of the first and second law of the thermodynamics of the system. In the right side Figure 4, it is appreciated that the total cost of the system with the increase of the isentropic efficiency of the turbine decreases. The increase of the isentropic efficiency of the gas turbine, and the fuel rate is reduced, which translates into reduction in rate of fuel cost

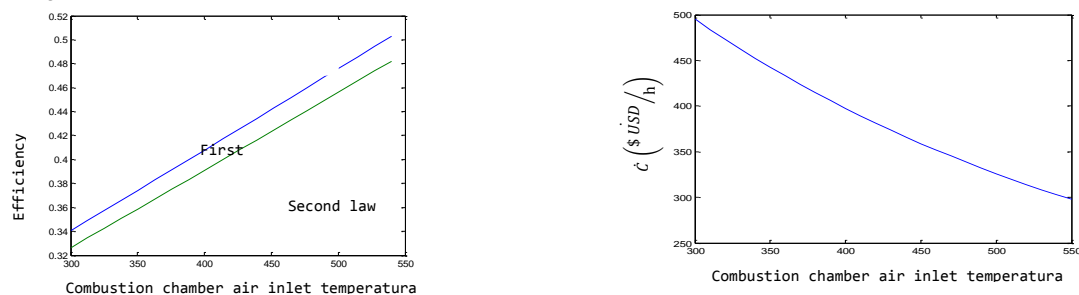

Figure 5. Combustion chamber air inlet: 300-540 (K)

By increasing the air outlet temperature of the air preheater, Figure 5 left side shows that both the efficiency of the first and second law of thermodynamics increase, as with the increase of the temperature of the incoming air to the combustion chamber, the fuel flow is decreased, leading to a decrease in heat in the combustion chamber and the exergetic requirement of entry into the combustion chamber, also, the total destruction rate of cycle exergy is reduced with the increase of the temperature of exit of the Preheater, Which causes an increase in the efficiency of the first and second laws of thermodynamics. Increase in the heat transfer area is required to increase the outlet temperature of the preheater which results in an increase in the value of  $(Z_k)$  for the preheater, however, this increase in the rate of cost of the air preheater is less than the decrease of the total cost of the fuel and exergetic destruction, as a result the total cost rate is reduced as shown in Figure 5 right side graph.

## 6. Conclusions

The system that has been proposed for this study includes a 30 kW Capstone, and a steam generator to produce saturated steam. The impact of varying design was measured. The main conclusions are as follows:

- One of the highest exergoeconomic analysis rate costs were taken into the flow of the compressor outlet; it is because all the exergy supplied to this flow is given by the mechanical compressor power.
- The results of the parametric studies show that increasing the compression ratio, efficiency of the micro turbine and improves thermodynamic system performance, however, increasing the compression ratio of the compressor increases rate system costs per unit of time.
- Increased compressor efficiency and isotropic micro turbine and the outlet temperature of the preheater will be useful for the system in thermal and economic terms.
- The highest rate of exergy destruction is in the combustion chamber, where all irreversibility sources are present.
- Having several preheaters of air in series with the entrance of this to the combustion chamber improves the overall efficiency of the whole system as long as the cost of these preheaters does not exceed the reduction of the total cost of the fuel saved.

The considerations in this study provide the basis for implementing practical engineering measures seeking to improve the thermal efficiency of the cogeneration system into consideration. However, the specific parameters that improve the thermal performance of a component could adversely affect another, leading to no improvement of system performance overall.

In addition, the measures taken to improve a system have economic consequences. The goal in designing a thermal system is typically identifying the most optimal configuration in terms of system costs, to achieve this, it requires a thermoeconomic optimization cycle which can be carried out in future work based on the results obtained in this study in the energy, exergetic and thermoeconomic analysis of a turbine 30 kW.

## Reference

- Bazzo, E., Nils, M., Jonsson, R., Karlsson, S. J., 2003. Thermoeconomic Analysis of a Small Scale Cogeneration.
- Bejan, A., Tsatsaronis, G., Moran, M. J., 1996. Thermal Design and Optimization.
- Cengel, Y. a., Boles, M. E., 2011. Termodinamica - Cengel 7th. Termodinamica, 7, 1456.
- Hosseini, S. E., Wahid, M. A., 2014. Enhancement of exergy efficiency in combustion systems using flameless mode. Energy Conversion and Management, 86, 1154–1163.
- Malinowski, L., Lewandowska, M., 2013. Analytical model-based energy and exergy analysis of a gas microturbine at part-load operation. Applied Thermal Engineering, 57(1-2), 125–132.
- Silveira, J. L., Tuna, C. E., 2003. Thermoeconomic analysis method for optimization of combined heat and power systems. Part I. Progress in Energy and Combustion Science, 29(6), 479–485.
- Blankinship, S., 2009. Microturbines provide police station CHP: Chicago is among the first U.S. cities to use microturbine-based CHP as a template for municipal office energy design . Power Engineering, 101.