



# Atomization Behavior as a Function of the Viscosity in a Rotary Disk Spray Dryer

Lucas B. Monteiro, Nelize M. de A. Coelho, Aldo R. Santos, Marlene S. de Moraes, Deovaldo de Moraes Júnior

Universidade Santa Cecília, Santos, São Paulo, Brasil  
[lucas.monteiro@unisanta.br](mailto:lucas.monteiro@unisanta.br)

During the spray drying it's important that the humid product doesn't reach the wall since it can result in losses and contamination. The main objective of the present work was to develop a method to quantify the influence of feed viscosity on atomization behavior in rotary disk spray dryer equipment. The secondary objective was to determine, as a function of rotation, viscosity, disk diameter and mass flow an empirical equation for the calculation of the maximum distance traveled by the fluid sprayed on the rotating disk. The results allowed to conclude that the better distribution was with the sugar solution, 50.10 mm diameter disk, 31,000 rpm, mass flow of  $0.55 \text{ g.s}^{-1}$  and maximum atomization range of 684 mm. The studied fluids were water and 50% mass base sugar solution. The experiments allowed the development of an empirical equation to obtain the maximum range from an atomized particle in function of the studied variables.

## 1. Introduction

### 1.1 Spray Dryer

As discussed by Masters (2002) spray dryer is an equipment that works to remove moisture from liquid fluids (suspensions of solids, pastes, sludge, among others) and obtain a final dried product in the form of powder. For this process, it is important to observe the behavior from the nebulized material, aiming to prevent accumulation and loss throughout the process. For this purpose, operational parameters and some fluid properties, such as viscosity, must be taken into account when designing an industrial scale equipment. The few data in the literature on the atomization of viscous fluids, together with the scarcity and closure of the design equations for this type of system, are the most important factors for this work.

Masters (2002) in his book that exclusively contemplates the spray dryers presents correlations for the sizing of a drying chamber. Green & Perry (2007) also provide a similar correlation with a difference in calculated volume value. By using algebraic correlations of cylinder volumes and truncated cone, it is observed that the equation recommended by Masters (2002) approximates the real value with deviation of less than 1%. Even so, this is very restricted, since it is only for drying chambers in which the diameter of the cylindrical part is tied to the other measures and the conical part with obligatory angulation of  $60^\circ$ .

This observation indicates that differences and inaccuracies may arise in the literatures on this subject. Furthermore, research on academic papers has revealed the existence of many studies focusing on optimizations for specific products, but studies of atomization-oriented design parameters are rare in the scientific milieu.

### 1.2 Objective

The main objective of the present work was to develop a method to quantify the influence of feed viscosity on atomization behavior in rotary disk spray dryer equipment. The secondary objective was to determine, as a function of rotation, viscosity, disk diameter and mass flow an empirical equation for the calculation of the maximum distance traveled by the fluid sprayed on the rotating disk.

## 2. Literature review

The spray dryer is an equipment consisting of a hollow chamber, which receives the solution to be dried from an atomization device. The droplets with the material to be dried come in contact with the hot fluid and with low moisture, being removed in the bottom of the equipment in the form of powder.

The basic operating principle of the spray dryer is to maximize the heat and mass transfer area of the solution through nebulization in the drying chamber (Rosa et al., 2003). One of the greatest advantages of this unitary operation is the low residence time of the material inside the chamber, which is approximately 25 seconds from the moment the material leaves the atomizer (Green & Perry, 2007). On the other hand, it presents a low yield, considering that much of the material, mainly at the beginning of the process, is retained in the walls of the equipment and, later, due to the low recovery rates of the cyclone (Goula & Adamopoulos, 2007). Another problem is the operation with amorphous and unstable particles that can facilitate the adsorption of the moisture present in the air.

The atomization process does not consist exclusively of the production of droplets by breaking the liquid tension, but also of ensuring the uniformity of mixing of a liquid in a gaseous medium. This process is used in several situations, from rocket fuel to boiler combustion systems that operate with liquid fuels, evaporative cooling, agricultural irrigation, spray drying, among others (Lefebvre, 1989; Günther & Wirth, 2013).

Atomization systems and their influence on droplet size have also been widely used in fog generators, with the purpose of suppressing fire, installed at a fixed location (sheds, industries, residences, among others) or in mobile systems such as airplanes and ships. Many cases have been tested and added to the literature, based on experiments conducted by the American Navy (Santangelo, 2010; Nduzibu et al., 1988; Adiga et al., 2007 and Mawhinney, 2016).

Another parameter of great importance in this step is the final morphology of the particle. Of great importance for, for example, the ceramic industry. The particle shape is influenced by the diameter and the drying process of the particle. When exposed to high or irregular rates of evaporation, the granule may eventually exhibit some type of deformation (Nishiura et al, 2010).

## 3. Materials and method

A spray dryer unit present in the Laboratory of Unitary Operations of the Santa Cecília University, located in Santos, São Paulo, Brazil, was used during the experiments. Figures 1 and 2 present an outline of the system designed for collecting the mist while Figure 3 shows the built-up equipment. The feed system consisted of a reservoir with a total height of 230 mm in the cylindrical part plus 35 mm in the conical section with an inner diameter of approximately 100 mm and a useful volume of 1.8 liters, a peristaltic pump with flow controller and pre-heating. The mist collector system was built with a steel support to hold the atomization system in the upper part and a wooden support star-shaped with eight directions, each one holding 10 acrylic plates containing adsorbent material. At the center of this star there's one more collector totalizing 81 collectors per experiment with a distance of 76 mm between each plate, to measure the behavior and the maximum range from the atomized particle, each one with.

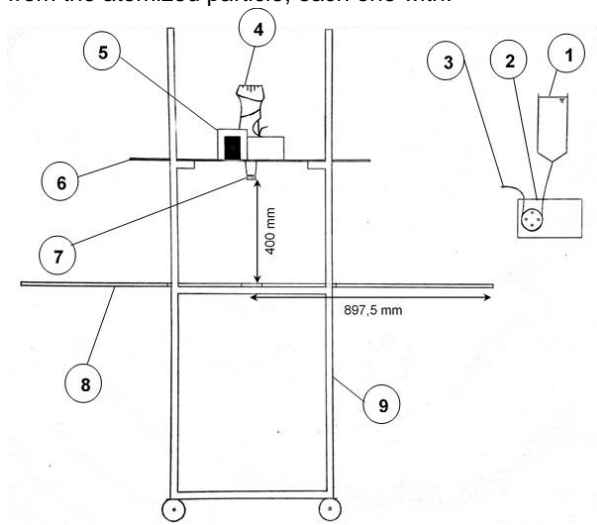

Figure 1 – System outline. 1) Solution's tank; 2) peristaltic pump; 3) feeding tube; 4) motor; 5) volute; 6) acrylic support with diameter of 920 mm; 7) atomizer disk; 8) wooden support e 9) structure with height of 1850 mm.

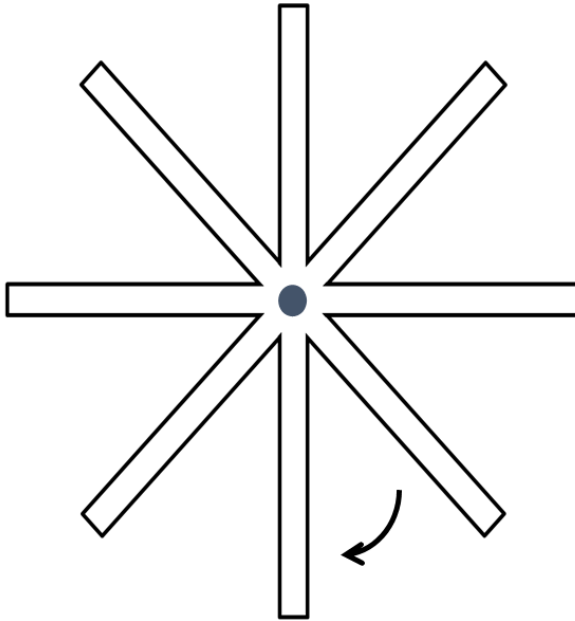

Figure 2 – Sketch in plan view from the wooden support with rotary disk position (dark point) and rotation (arrow).

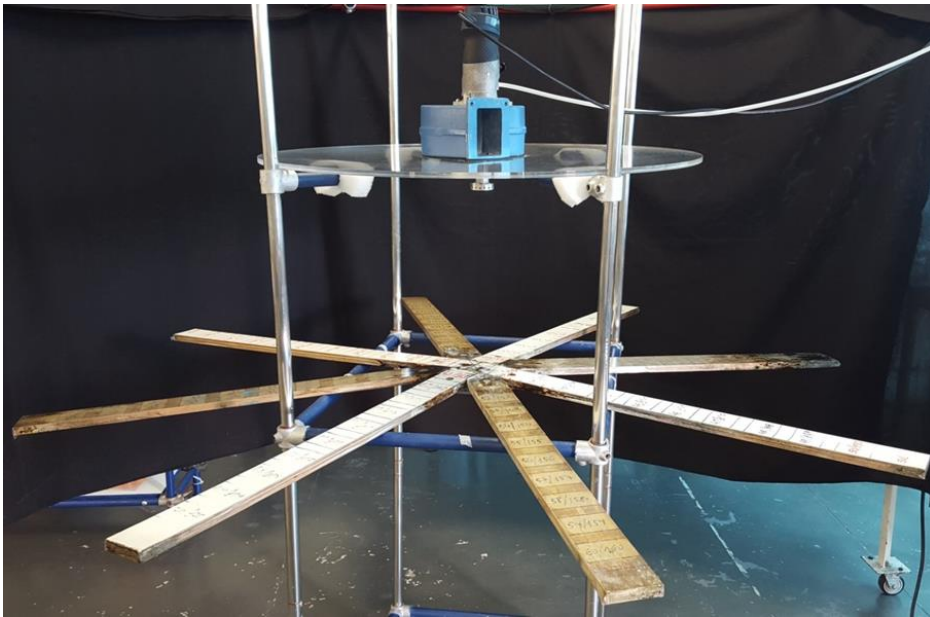

Figure 3 – Data collect system.

An experimental design  $2^4$  was proposed (Table 1), resulting in 16 trials performed, all in duplicates, thus totaling 5184 total weighing in the experiment. Level 2 (base) refers to two flows, two rotations, two fluids and two discs with the exponent 4 of the mentioned variables (flow, rotation, fluid and disk). The collect was performed with the aid of 81 acrylic plates containing adsorbent material. The results obtained were statistically treated with the help of the Minitab Software to obtain a Pareto plot and allow the analysis of the influences of each process variable and subsequent obtaining of an empirical equation to verify the maximum reach of the atomization mist.

For all the experiments the temperature of the fluid was the same from the ambient where the tests were conducted, being that controlled in the value of 22 °C.

Table 1 – Design of experiments 2<sup>4</sup>.

Experiment	Fluid	Disc (mm)	Rotation (rpm)	Mass flow (g.s <sup>-1</sup> )
1	Water (1 cP)	30.2	31,000	1.34
2				0.55
3			17,000	1.34
4				0.55
5		50.1	31,000	1.34
6				0.55
7			17,000	1.34
8				0.55
9	Sugar Solution, 50%Wt (35,31 cP)	30.2	31,000	1.34
10				0.55
11			17,000	1.34
12				0.55
13		50.1	31,000	1.34
14				0.55
15			17,000	1.34
16				0.55

#### 4. Results and discussion

Figure 4 presents a comparison between the best experiment performed with water and the best with the sugar solution.

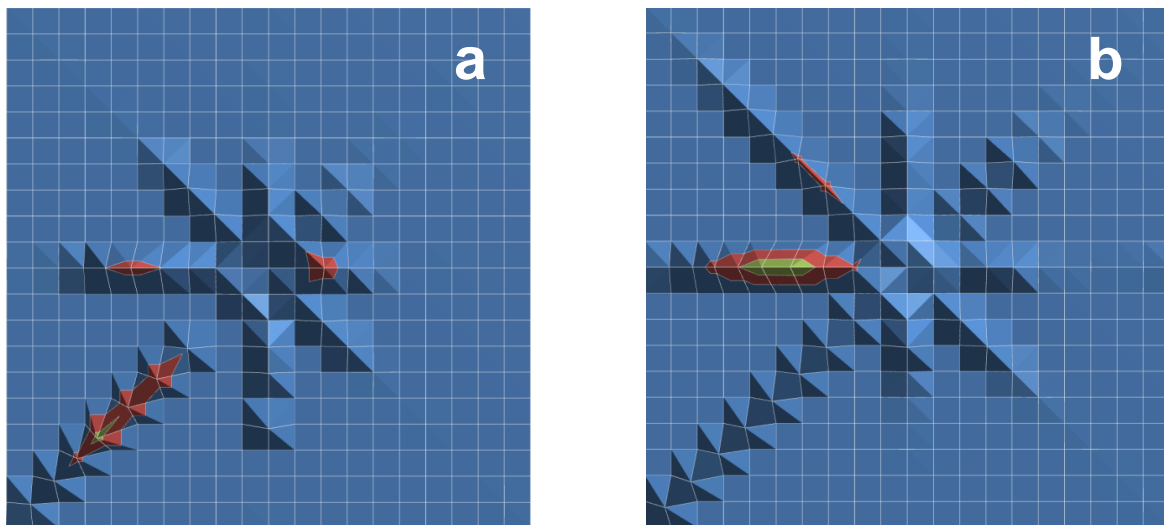

Figure 4 – Behaviour from experiments: a) 4 (water; 30.2 mm; 17000 rpm e 0.55 g.s<sup>-1</sup>) and b) 12 (sugar solution 50%Wt; 30.2 mm; 17000 rpm e 0.55 g.s<sup>-1</sup>).

All the qualitative analyses of the distribution of the atomization in the system were carried out regarding the uniformity of the mass distribution on the collectors. It was also observed in all the experiments carried out that there is a preferential path occurring in the atomization process. This phenomenon is characterized by the accumulation of unidirectional mass probably caused by the feeding of the disk in only one point, common in the industrial units.

In both cases, there's a more concentrated region of the atomized material, which when working with an inlet air entrance may cause problems to carry those particles, allowing them to still reach the wall. This region was considered the critical point from the atomization inside a drying chamber, making it the minimal allowed diameter for this kind of equipment. For the water, considering a very diluted solution that must be dried, the minimal diameter was of 532 mm, considering the farther point from concentrated region as the lower diameter. Using the same considerations with the sugar solution, the minimal diameter from this equipment must be of 684 mm.

It's also possible to observe that the viscosity has influence in the distribution of the material since in Figure 4.b we can see more material to the left side of system as farther points with mass collected to the right side if compared with the water in Figure 4.a.

Figure 5 shows the Pareto graph obtained in Minitab, which allows to verify which parameters influence in the maximum travelled distance by the particle from the atomizing disk until reaching the adsorbent material.

Through the analysis performed, it is possible to observe that the isolated and combined parameters whose effects exceed the critical value of Student's T with 95% confidence level (2.120) are those that in fact influenced the distance of the fluid when leaving the atomizer disk. Based on the above-mentioned Figure 5, it was possible to develop empirical Equation 1, that is valid only within the experimental limits.

$$A = 1,714 - 0,499 \cdot \mu - 0,0435 \cdot D - 4,5 \times 10^{-5} \cdot n - 0,192 \cdot \dot{m} + 1,3 \times 10^{-3} \cdot \mu \cdot D + 10^{-6} \cdot \mu \cdot n + 10^{-6} \cdot D \cdot n \quad (1)$$

being

A the maximum range, in m;

$\mu$  the absolute dynamic viscosity, in cP;

D the atomizing disk diameter, in mm;

n the atomizing disk rotation, in rpm;

$\dot{m}$  the system feeding mass flow, in g/s.

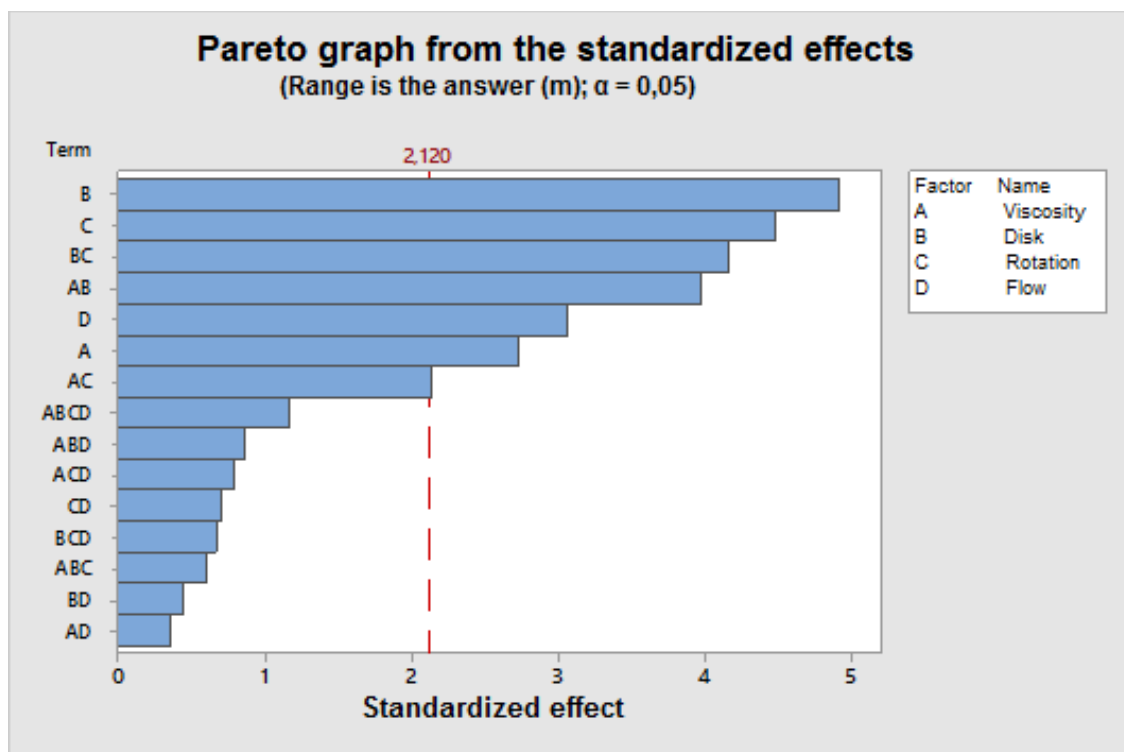

Figure 5 – Pareto plot which A is the viscosity, B is the disk diameter, C is the disk rotation e D is the mass flow.

## 5. Conclusion

The developed and applied method allows to quantify and observe the behaviour, distribution, range and concentration of mass in each of the defined distances for the experiment.

The obtained equation allows, for the studied conditions, to quantify the maximum space travelled by the particle and, consequently, the minimum diameter that the drying chamber must have to avoid incrustation and contamination on the walls of the equipment with humid particles.

To continue the studies, other fluid properties may be considered as other operational parameters. To have a more accurate behaviour and distance from the atomized material, a full wooden support must be constructed to try to mitigate the regions without collectors.

## Acknowledgments

The authors would like to acknowledge the Santa Cecília University for allowing the use from its laboratory for the experiments.

## Reference

- Adiga, K.C.; Hatches Jr., R.F.; Sheinson, R.S.; Williams, F.W.; Ayers, S.; A computational and experimental study of ultra fine water mist as a total flooding agent. *Fire Safety*, 42, 2007.
- Goula, A. M.; Adamopoulos, K. G.; Influence of Spray Drying Conditions on Residue Accumulation—Simulation Using CFD. *Drying Technology*, 2007.
- Green, D. W.; Perry, R. H.; Perry's chemical engineers' handbook. 8th ed., New York, McGraw-Hill, 2007
- Günther, A.; Wirth, K. –E.; Evaporation phenomena in superheated atomization and its impact on the generated spray. *International Journal of Heat and Mass Transfer*, 64, 2013.
- Langrish, T.; Applying Mass and Energy Balances to Spray Drying. *AIChE/CEP*, Dezembro, 2009.
- Lefebvre, A. H.; Atomization and Sprays. 1989.
- Masters, K.; Spray Drying in Practice. SprayDryConsult International ApS, Denmark, 2002.
- Mawhinney, J. R.; Engineering Criteria for Water Mist Fire Suppression System. National Research Council Canada, accessible in < <http://www.fire.tc.faa.gov/pdf/fsr-0023.pdf>> Accessed in 07/02/2016.
- Nishiura, D.; Shimosaka, A.; Shirakawa, Y.; Hidaka, J.; Simulation of Drying of Particulate Suspension in Spray-Drying Granulation Process. *Journal of Chemical Engineering of Japan*, Vol. 43, 2010.
- Nduzibu, C. C.; Ananth, R.; Tatem, P. A.; Motevalli, V.; On water mist fire suppression mechanisms in a gaseous diffusion flame. *Fire Safety Journal*, 31, 1998.
- Rosa, E. D.; Tsukada, M.; Freitas, L. A. P. Secagem por atomização na indústria alimentícia: Fundamentos e aplicações. 2003, 12p.
- Santangelo, P. E.; Characterization of high-pressure water-mist spray: Experimental analysis of droplet size and dispersion. *Experimental and Thermal Fluid Science*, 34, 2010.