

Effect of Oxidation Reduction Potential (Eh) on the Biocatalytic Oxidation of As³⁺ to As⁵⁺ in a Mixed Culture of Chemoautotrophic Bacteria

Tony E. Igboamalu*, Atlegang Nyakale, Mpumelelo T. Matsena, Evans M.N. Chirwa

Department of Chemical Engineering, University of Pretoria, Pretoria 0002, South Africa
 Tony.Igboamalu@gmail.com

Biocatalytic oxidation of Arsenite (As³⁺) to arsenate (As⁵⁺) in a mobilized and immobilized chemoautotrophic bacterium has been a challenging area of metallic bioremediation research. This is because arsenic in its trivalent form (As(III)) is a major water pollutant and a threat to the human health and the environment. Previous studies have shown that Gram-positive species: *Bacillus* sp., and *Exiguobacterium* sp, has the tendency to biologically catalyse or mediate the oxidation of As³⁺ to As⁵⁺. The redox process is believed to be thermodynamic feasible because of the Mo⁶⁺ content of the microbial cell sub unit, acting as an electron acceptor for As³⁺ oxidation with adequate amount of energy generated for cell growth and metabolism. The changes in arsenic oxidation state (i.e. +3 to +5) is a natural process, and it is not well understood. However, the current study investigates or validate the changes in oxidation state of arsenic from +3 to +5 in a mobilized cell at various Oxidation Reduction Potential (ORP) and pH subjected to different arsenic concentrations ranging from 50 mg/L to 100 mg/L. It was observed that there exists a proportional relationship between increasing the arsenic concentration and achieving high ORP values. The maximum ORP achieved in the anaerobic batch experiment increased from -15.9 mV at 50 mg/L, to -14.8 mV at 80 mg/L and to -12.5 mV at 100 mg/L. It was evident that the ORP increased at 100 mg/L from -16.1 mV to -12.5 mV, indicating possible electron switch. Arsenic oxidation was highly favoured in anaerobic conditions than in aerobic conditions.

1. Introduction

Arsenic is a semi-metal with an atomic number of 33 and molar mass of 74.92 g/mol. It has two biologically important oxidation states, As(III) and As(V). Oxidation state, oxidation reduction potential, pH, iron concentrations, metal sulphide and sulphide concentrations, temperature, salinity and distribution and composition of biota appear to be significant factors that determine the fate and transport of arsenic As(III) which poses a serious threat to human health and the environment especially at very low concentrations (Tchounwou et al., 2004). Research work has been conducted, focusing on oxidising arsenic (As(III)) to arsenate (As(V)) which is more stable (Kruger et al., 2013). Due to the ionic charge, arsenate (V) is more easily removed from source waters than arsenite (III) (Ning 2002). A previous study has shown that bacteria has developed various mechanisms for oxidising As(III), resulting to energy generation while utilizing CO₂ as a carbon source (Santini et al., 2000). Various studies have reported the microbial interaction with As(III), of which could be either be by arsenic resistance structure as genes (Rosen, 2002) or respiratory or non-respiratory oxidation structure (Muller et al., 2003). In the current study, the oxidation of As(III) in the presence of a mixed culture of bacteria was evaluated according to Eq(1), Eq(2) and Eq(3) (Igboamalu and Chirwa, 2018).

As(III) oxidation:



Molybdenum (Mo(VI)) reduction:



Overall redox reaction:



Considering bio-catalytic redox reaction described by Eq(2) and Eq(3), As(III) oxidation removal seems to be feasible in the presence of Mo(VI) (Igboamalu and Chirwa, 2017). It could be seen that from the cell protoplasm under normal favourable environmental conditions, As(III) tends to donate 2e^- , and oxidises to As(V), while Mo(VI) accepts 2e^- and reduced to molybdenum (IV) (Mo(IV)) (Igboamalu and Chirwa, 2017). The redox process is believed to be thermodynamic feasible because of the Mo^{6+} content of the microbial cell sub unit, acting as an electron acceptor for As^{3+} oxidation with adequate amount of energy generated for cell growth and metabolism. The changes in arsenic oxidation state (i.e. +3 to +5) is a natural process, and it is not well understood. The current study investigates the changes in oxidation state of arsenic from +3 to +5 in a mobilized cell at various Oxidation Reduction Potential (ORP) and pH subjected to different arsenic concentrations ranging from 50 mg/L to 100 mg/L.

A continuous reactor (biofilm) consisting of a mixed culture of bacteria was continuously operated for 36 days. Glucose and sodium bicarbonate were used as carbon sources for the different arsenic concentration runs. The following arsenic concentrations were respectively used to run the biofilm; 50, 80 and 100 mg/L. Samples were taken daily from the four sample ports of the reactor. ORP and pH were measured variables.

2. Materials and methods

2.1 Bacterial culture

Indigenous mixed culture of bacteria was collected from a cow dip in Limpopo, South Africa. capable of mediating oxidation of As(III) were identified in the mixed culture.

2.2 Basal mineral salt and growth media

Basal mineral salt media (BMM) was prepared by dissolving: 10 mM NH_4Cl , 30 mM Na_2HPO_4 , 20 mM KH_2PO_4 , 0.8 mM Na_2SO_4 , 0.2 mM MgSO_4 , 50 μM CaCl_2 , 25 μM FeSO_4 , 0.1 μM ZnCl_2 , 0.2 μM CuCl_2 , 0.1 μM NaBr , 0.05 μM Na_2MoO_2 , 0.1 μM MnCl_2 , 0.1 μM KI , 0.2 μM H_3BO_3 , 0.1 μM CoCl_2 , and 0.1 μM NiCl_2 . The media was sterilised before use by autoclaving at 121 °C at 115 kg/cm² for 15 minutes. Luria-Bettani (LB) broth was prepared by dissolving 25 g LB in 1 L of distilled water, and sterilised before use by autoclaving at 121 °C at 115 kg/cm² for 15 minutes. The LB broth was stored at 4 °C (Mtimunye, 2011).

2.3 Measurement

A multifunctional meter Ezodo PL-700ALS (Gondo Electronic Co Ltd., Tapei, Taiwan) was used to measure the oxidation reduction potential (ORP) and the pH of the samples. The ORP is measured in millivolts (mV) using an ORP electrode.

2.4 Anaerobic batch reactor studies

All batch studies were done under these conditions: Indigenous mixed culture of bacteria collected from a cow dip in Limpopo, South Africa was grown for a desired period of incubation time at a temperature of 30 ± 1 °C at 150 rpm anaerobically in Erlenmeyer flasks containing the desired volume of LB broth. Cells were harvested by centrifuging at 6000 rpm at 4 °C for 10 minutes, the supernatant was discarded, and the pellet was washed three times in a sterile solution of 0.85 % of NaCl whilst centrifuging. Experiments were conducted in 100 mL serum bottles by adding both arsenite (III) and carbon source in basal mineral media to give a total volume of 100 mL. Before the experiments, initial measurements were taken, and the harvested cells were then added in the serum bottles. The bottles were then sealed with rubber stoppers and were incubated at a temperature of 30 ± 1 °C at 150 rpm.

2.5 Continuous reactor set-up

The continuous flow reactor was constructed from a glass column (height: 70 ± 0.01 cm, internal diameter 10 ± 0.01 cm) packed with 0.6 cm spherical glass beads. The packed bed reactor has a volume of 5497.79 cm³. For a working reactor volume of 5497.79 cm³, the reactor effluent was used to pre-calibrate peristaltic pumps used to achieve the desired volumetric flow rate. The reactor was operated in an up-flow mode and was designed to operate continuously at hydraulic retention time of 11.9 h. The reactor consisted of sample ports of same diameter. Two pumps were used to pump the influent into the reactor and the recycle back into the reactor respectively. Figure 1 shows the reactor set-up and Table 1 shows the specifications of the reactor.

2.6 Reactor start-up

The reactor was filled with LB broth to the top of the column and then run on a cultured cell medium recycle. The cells were cultured in a 1000 mL flask with LB Broth and 20 mL of the collected bacteria-containing water sample. The cells were cultured for a period of 24 h. The recycling of cells was done for 3 weeks to allow cell attachment on the solid glass beads in the reactor. After a period of 3 weeks the biofilm was clearly established on the glass beads, the reactor was then operated under influent As(III) concentration at volumetric flow rate 0.128 cm³/s. An initial As(III) concentration of 50 mg/L was used. The concentration was changed to 80 mg/L after 5 days and to 100 mg/L after running the biofilm at 80 mg/L for 4 days.

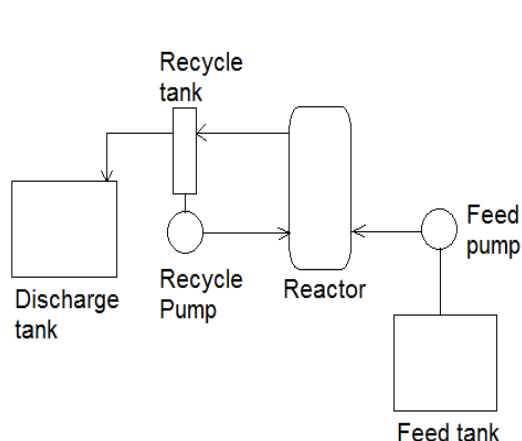

Figure 1: Reactor set-up

Table 1: Reactor design and operational properties

Parameter	Units	Value
Column diameter	cm	10
Column height	cm	70
Column mass	g	583.77
Glass beads mass	g	1210.04
Reactor volume	cm ³	5497.79
Volumetric flow rate	cm ³ /s	0.128
Retention time	h	11.9
Bead diameter	cm	0.6 ± 0.4
Spherical bead surface area	cm ²	0.322
Room temperature	°C	30 ± 0.1

3. Results and discussion

3.1 Effect of carbon sources on ORP

Anaerobic batch experiments were conducted under six different conditions. Glucose and sodium bicarbonate were used as carbon sources to investigate the change in the ORP as time progresses. Table 2 shows the batch experimental conditions.

Table 2: Anaerobic batch experimental conditions

Experiment	Experimental conditions
Control 1	MSM + cells + 0.2 g sodium bicarbonate.
Control 2	MSM + cells + 0.2 g glucose.
Control 3	MSM + cells + 80 ppm As(III).
Experiment 1	MSM + cells + 0.2 g sodium bicarbonate + 80 ppm As(III).
Experiment 2	MSM + cells + 0.2 g glucose + 80 ppm As(III).
Experiment 3	MSM + cells + 0.2 g glucose + 0.2 g sodium bicarbonate + 80 ppm As(III).

Control 1 and Control 2 studies in Figure 2a show that in the presence of cells, adding a carbon source only (sodium bicarbonate or glucose) will not affect ORP that much. Control 3 also shows that the adding As(III) only in the presence of cells without a carbon source will not change ORP of the solution. As(III) was added to sodium bicarbonate and cells in Experiment 1 and the ORP didn't change that much. However in Experiment 2, ORP resulted in an increase which was higher than one in Experiment 3 as shown in Figure 2b within the first 7 h. This means that glucose enhanced microbial growth and therefore a faster redox reaction according to Eq(3) resulting in the fast increase in ORP. This result is consistent with the study done by Otter et al. (2017) where As(III) oxidation is related to high ORP values.

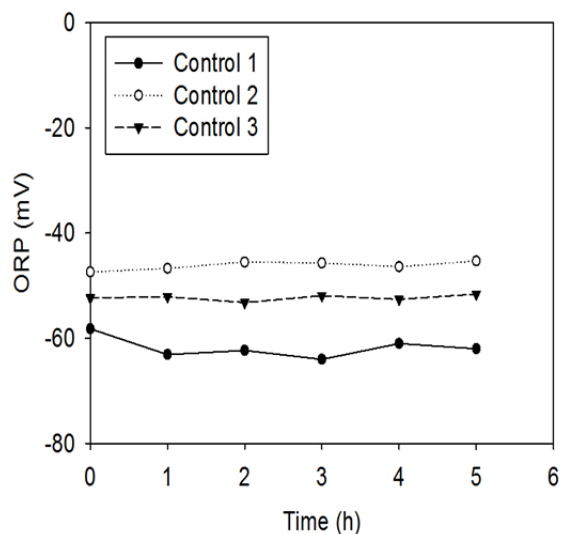

Figure 2a: Anaerobic ORP batch results for Controls 1, 2 and 3.

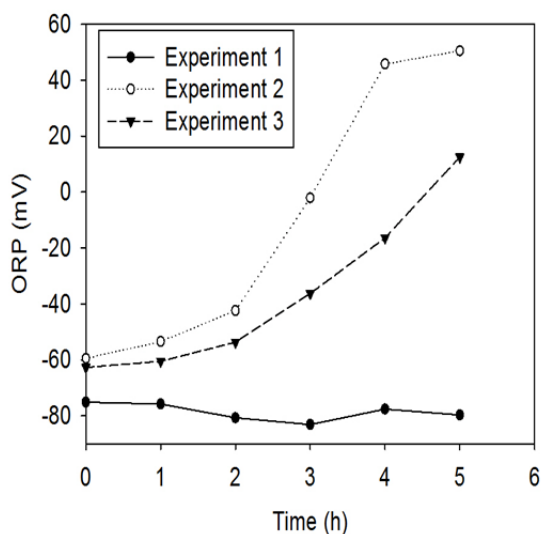

Figure 2b: Anaerobic ORP batch results for Experiments 1, 2 and 3.

3.2 Comparing aerobic and anaerobic conditions

In Section 3.1, it was shown that adding As(III) and glucose in presence of microbial cells under anaerobic conditions increases ORP leading to enhanced oxidation of As(III). Using the same optimal conditions of Experiment 2 shown in Table 1, anaerobic condition was changed to aerobic to see the effect of oxygen presence on ORP. It can be seen in Figure 3 that aerobic conditions didn't lead to ORP increase. This means that the microbial cells were anaerobes and couldn't oxidise As(III) under aerobic conditions.

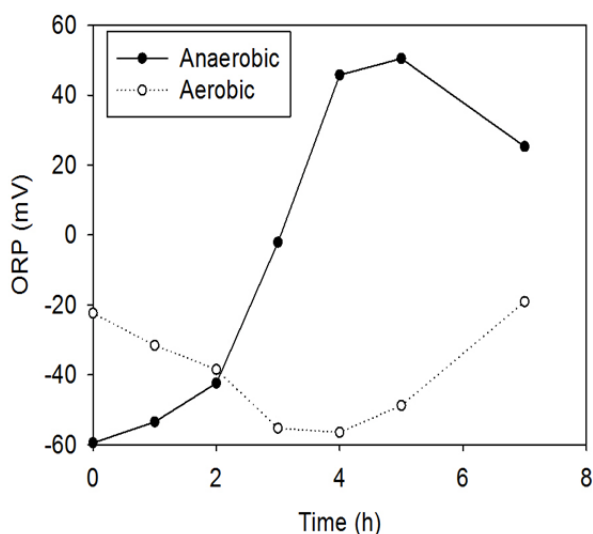

Figure 3: Aerobic and anaerobic experiment 2 ORP measurements.

3.3 Varying As(III) concentration on ORP and pH

Concentration of arsenic concentrations may be elevated in water due to anthropogenic sources such as mining and agrochemical manufacturing in the range of 12 mg/L to 35 mg/L (WHO, 2011). Therefore in this study, the range used for our experiments was 50 to 100 mg/L. Increasing the concentration of As(III) led to an increase in ORP as shown in Figure 4. The maximum ORP achieved in the anaerobic batch experiment increased from -15.9 mV at 50 mg/L, to -14.8 mV at 80 mg/L and to -12.5 mV at 100 mg/L. It was evident that the ORP increased at 100 mg/L from -16.1 mV to -12.5 mV, indicating possible electron switch. Therefore these results indicated that an increase in the solutions potential to oxidise As(III) with an increase in As(III)

initial concentration is possible in presence of cells and glucose under anaerobic conditions. Initial As(III) concentration of 100 mg/L favoured As(III) oxidation.

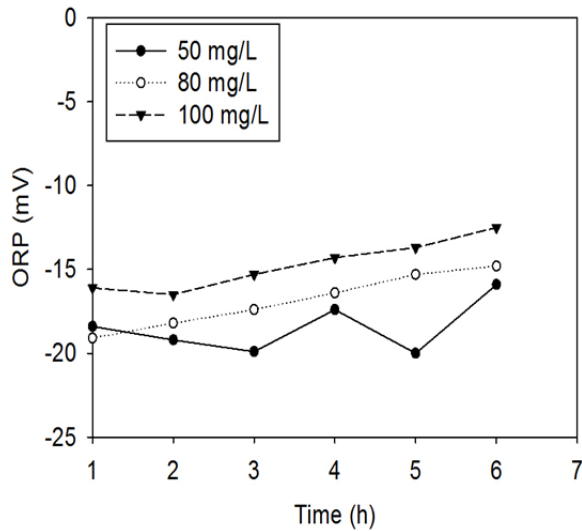

Figure 4: Batch anaerobic ORP measurements at different As(III) concentrations.

3.4 Continuous reactor

The outlet of the continuous reactor was monitored for ORP. It is observed in Figure 5a that the ORP at each concentration reaches a maximum and then decreases. The maximum ORP indicates the solutions maximum oxidising strength and it increases as the initial concentration of As(III) increases. An increase in As(III) concentration led to a decrease in pH as shown in Figure 5b. Otter et al. (2017) was able to show that in as much as high ORP values favour As(III) oxidation, the other condition that must be satisfied is that the pH should be low. Therefore 100 mg/L As(III) concentration at the exist port has the highest oxidising strength. This is consistent with the batch results meaning also under continuous operation, there is an increase in the solutions potential to oxidise As(III) with an increase in As(III) initial concentration.

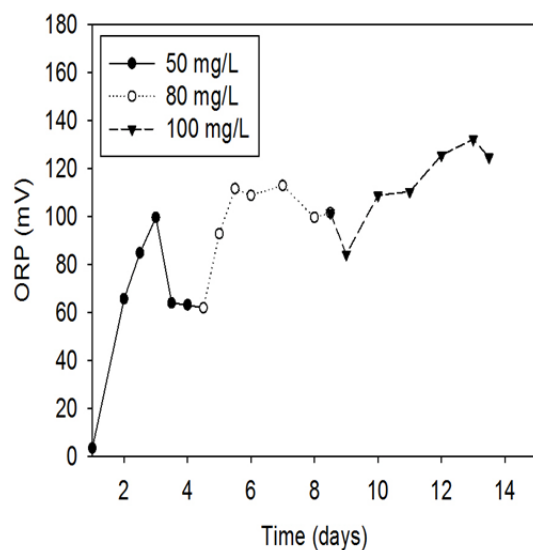

Figure 5a: Continuous anaerobic ORP measurements at different As(III) concentrations.

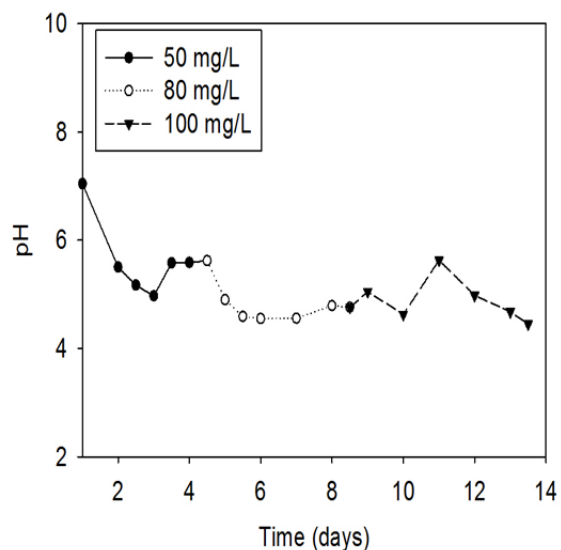

Figure 5b: Continuous anaerobic pH measurements at different As(III) concentrations.

4. Conclusions

It was observed that there exists a proportional relationship between increasing the arsenic concentration and achieving high ORP values. The maximum ORP achieved in the anaerobic batch experiment increased from -15.9 mV at 50 mg/L, to -14.8 mV at 80 mg/L and to -12.5 mV at 100 mg/L. It was evident that the ORP increased at 100 mg/L from -16.1 mV to -12.5 mV, indicating possible electron switch. Arsenic oxidation was highly favoured in anaerobic conditions than in aerobic conditions. These results indicated that an increase in the solutions potential to oxidise As(III) with an increase in As(III) initial concentration is possible in the presence of cells and glucose under anaerobic conditions. Under continuous runs, the maximum ORP indicated the solutions maximum oxidising strength and it increased as the initial concentration of As(III) increased.

Acknowledgments

The authors would like to thank Mrs. Alette Devega for assistance during this research.

References

- Igboamalu T.E., Chirwa E.M.N., 2018, As(III) Oxidation and electron mass transfer kinetic in an enriched mixed culture of bacillus sp., and exiguobacterium sp., isolated from cow dip in South Africa. *Chemical Engineering Transactions*, 64, 505-510.
- Igboamalu T.E., Chirwa E.M.N., 2017, As(II) oxidation and Cr(VI) reduction insight in an indigenous mixed culture of anaerobic bacteria from a local environment, *Chemical Engineering Transactions*, 61, 259-264.
- Kruger M.C., Bertin P.N., Heipieper H.J., Arsène-Ploetze F., 2013, Bacterial metabolism of environmental arsenic—mechanisms & biotechnological applications, *Applied Microbiology & Biotechnology*, 97, 3827-3841.
- Mtimunye P.J., 2011, A Steady-State Model for Hexavalent Chromium Reduction in Simulated Biological Reactive Barrier: Microcosm Analysis, University of Pretoria, Pretoria, South Africa. <https://repository.up.ac.za/bitstream/handle/2263/28130/dissertation.pdf%3Bsequence%3D1%ved=2ahUahUKE_IK4o4XIAhX3QUEAHY2IBd4QFjAAegQIBRAC&usg=AOvVaw3k04bZ-0wEP6bl85f60WKQ> accessed 23 Oct 2018.
- Muller D., Lievreumont D., Simeonova D.D., Hubert J.C., Lett M.C., 2003, Arsenite oxidase aox genes from a metal-resistant β -proteobacterium, *Journal of Bacteriology*, 185, 135-141.
- Ning R.Y., 2002, Arsenic removal by reverse osmosis, *Desalination*, 143, 237-241.
- Rosen B.P., 2002, Biochemistry of arsenic detoxification, *FEBS Letters*, 529, 86-92.
- Santini J.M., Sly L.I., 2000, A new chemolithoautotrophic arsenite-oxidizing bacterium isolated from a gold mine: phylogenetic, physiological, and preliminary biochemical studies, *Applied and Environmental Microbiology*, 66, 92-97.
- Tchounwou P.B., Centeno J.A., Patlolla A.K., 2004, Arsenic toxicity, mutagenesis, and carcinogenesis—a health risk assessment and management approach, *Molecular and Cellular Biochemistry*, 255, 47-55.
- Otter P., Malakar P., Jana B.B., Grischek T., Benz F., Goldmaier A., Feistel U., Jana J., Lahiri S., Alvarez J.A., Arsenic removal from groundwater by solar driven inline-electrolytic induced co-precipitation and filtration—a long term field test conducted in west Bengal, *Int. J. Environ. Res. Public Health*, 14, 1167-1188.
- World Health Organisation (WHO), 2011, Arsenic in Drinking Water, World Health Organisation <www.who.int/water_sanitation_health/publications/arsenic/en/> accessed 18.03.2019.