

Gas Separation Hollow Fiber Membranes: Processing Conditions for Manipulating Morphology and Performance

Paola Bernardo*, Franco Tasselli, Gabriele Clarizia

Istituto per la Tecnologia delle Membrane, Consiglio Nazionale delle Ricerche, via P. Bucci 17/c, 87036 Rende CS, Italy
p.bernardo@itm.cnr.it

Currently, membrane unit operations are widely applied at industrial level, replacing conventional separation systems. Membrane gas separation represents a successful case, with an increasing number of installed plants in chemical processes, petrochemical plants and refineries for the production of nitrogen from air, the hydrogen separation and recovery and the carbon dioxide separation from natural gas. Owing to the low space footprint and low energy consumption, membrane separation is an environmental friendly technique that meets the Process Intensification requirements.

The present study concentrates on the hollow fiber (HF) configuration that is the most used in applications of industrial interest. HF modules, having a high membrane packing density, are compact devices with thousands of square meters of membrane area per unit of volume.

The required membranes have an asymmetric structure, in which a thin dense layer performs the separation and a porous substructure provides the needed mechanical resistance. The manipulation of the HFs morphology, according to a dry-wet spinning process in a pilot plant apparatus, investigating the effect of the operating conditions adopted for the spinning on the membrane performance and microstructure, is experimentally examined. Commercially available glassy polymers are used to make a comparison of a conventional double orifice spinneret with a triple orifice spinneret. The prepared HF batches are characterized by means of a morphological characterization (SEM analysis) and gas permeation rate measurements.

1. Introduction

Membrane gas separation is recognized as a valuable alternative to conventional energy-intensive separation processes such as distillation or adsorption (Bernardo et al., 2009). Currently, membrane plants are installed in different industrial sectors for gas and vapour separation. They cover a wide range of applications such as hydrogen recovery in refineries, natural gas sweetening and biogas upgrading, VOC recovery and air separation (Bernardo and Clarizia, 2013). The integration of membrane systems with conventional operations is also considered to intensify separations for a successfully application at industrial level (Ortiz et al., 2018).

Typically, hollow fibers (HFs) are widely used as gas separation membranes. In fact, this geometry provides different advantages over flat-film and spiral-wound modules, such as a superior membrane packing density, which results in high membrane area within compact modules (Mulder, 2003).

In general, the hollow fiber spinning presents several peculiar parameters that, if properly controlled, lead to the desired morphology and consequently tailored transport properties. They can be distinguished in chemical-physical and geometric/fluid-dynamic variables. The composition and concentration of the dope and bore fluid, the operating temperature are the main chemical parameters that can be varied during the spinning process. Instead, the geometric dimensions of the spinneret, the air gap, the dope and bore fluid flow rates are some of the main parameters related to the system engineering.

Consequently, there are different possibilities to tune the membrane performance in the case of HFs with respect to flat-sheet membrane configuration.

In this work, the effect of the above mentioned operation parameters was experimentally evaluated. A careful design of the spinning operating conditions for producing different HF batches was adopted in order to highlight the existence of synergies among some of them. Commercial glassy polymers (e.g., polyimide and

polysulfone), typically applied for the industrial membrane preparation, were adopted. Some guidelines are identified, showing the procedures that ensure membranes with a good interplay of gas permeance and selectivity.

2. Materials and methods

2.1 Materials

Polysulfone (PSf, Udel® P-3500), was supplied by Solvay (Belgium). The polyimide Matrimid® 5218 was received from Huntsman Advanced Materials (Europe). N-methyl-2-pyrrolidone (NMP), supplied by VWR, was used as solvent for both polymers. Single permanent gases (e.g., N₂, CH₄ and CO₂) were used for permeation tests and purchased from SAPIO (Italy).

2.2 Membrane preparation

Different HF batches were spun according to a dry-jet wet technique, using alternatively a double and a triple orifice spinneret within the pilot plant described in Figure 1 (Tasselli and Drioli, 2007).

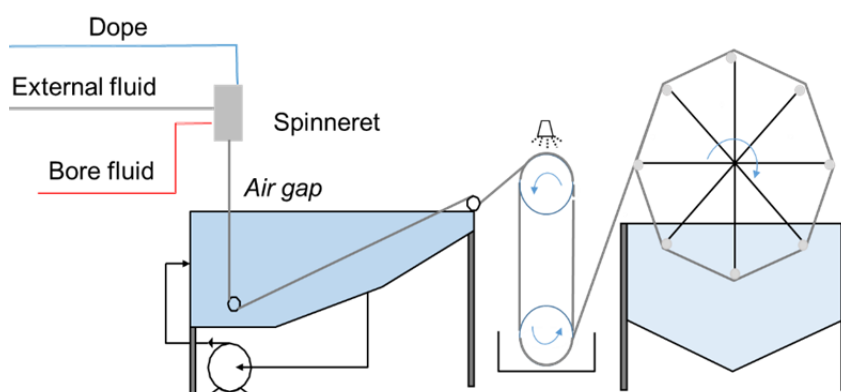

Figure 1: Scheme of the pilot plant for the spinning

The polymers were dissolved in NMP, which has a good compatibility with the coagulation medium (water), while its low volatility reduces evaporation losses in the environment.

The as-spun fibers were immersed in deionized water for 3 days to remove the residual solvent and air-dried before their characterisation and use in gas separation.

2.3 Membrane characterization

The prepared membranes were characterized measuring their gas permeation rate properties at 25°C and 1 bar of feed pressure in a fixed-volume/variable-pressure set-up (Clarizia et al., 2018). The gas permeance is expressed in GPU (1 GPU = 1×10^{-6} cm³ (STP)/cm² s cmHg). The ideal separation factor for a certain gas pair is determined as the ratio of individual permeance values.

The morphology of the membranes was investigated by means of scanning electron microscopy (SEM) on an EVO|MA 10 (Zeiss, Italy) instrument.

2.4 Approach and Methods

The general approach adopted in this work, was aimed at increasing the gas permeation rates through the HFs in order to enhance the productivity, reducing the required membrane area for a fixed flow rate of the stream to be treated in the membrane separation system. Therefore, the spinning was carried out investigating the role of the following parameters:

- Dope polymer composition and concentration,
- Bore fluid (BF) composition and concentration,
- Temperature,
- Flowrates ratio (BF/Dope),
- Spinneret type (double or triple),
- Spinneret dimensions (cross section ratio, BF/Dope),
- Air gap.

Concerning these parameters, it is noteworthy to underline some points. First, HF preparation requires a higher dope concentration with respect to flat-sheet membranes. However, there is a critical concentration for attaining viscosity levels suitable to produce self-standing samples. It depends mainly on the dope chemistry (e.g., polymer and solvent type), but also on operation conditions. Gelation should be avoided as well. The air gap is the distinctive element in dry-wet phase inversion process for HF preparation (Khayet, 2003). It induces elongational stresses because of gravity and allows the mass exchange in dry phase before the coagulation step. Finally, the use of a triple-orifice as an alternative to traditional double-orifice spinneret provides another line that can be fed with a different fluid, thus giving further options to change the membrane microstructure, specifically acting on the outer HF region (Bernardo et al., 2019).

3. Results

Membranes for gas separation applications require a dense selective layer to perform the separation at a molecular level. At the same time, a very thin skin layer is desired to achieve more permeable samples. Usually, the structure resulting from a dry-jet/wet spinning is asymmetric, with denser layers on the inner and outer surfaces and a porous substructure that acts as mechanical support (Figure 2a). The effective permeance of the whole asymmetric structure can be estimated by considering a simplified series model in which the different resistances are connected as represented in Figure 2b. Each layer, depending on its thickness and microstructure, contributes to the overall resistance offered to the mass transfer. In particular, the porous region closer to the skin layers can exert a not negligible role in the measured permeance (Clausi et al., 1999).

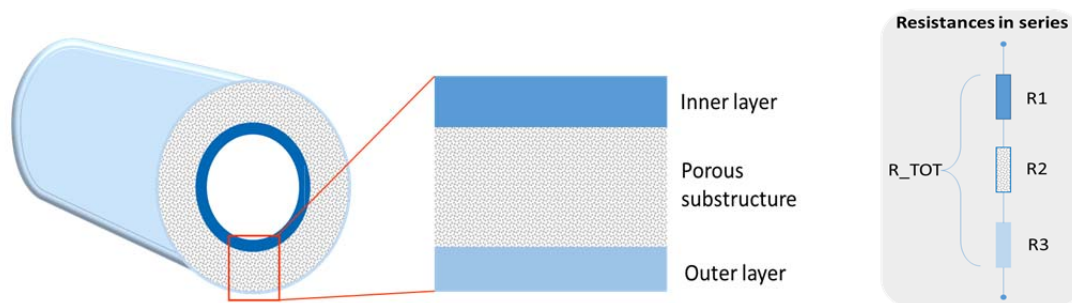

Figure 2: a) Scheme of an asymmetric HF membrane and b) representation of the main transport resistances.

Typically, a reduced polymer concentration in the dope produces a structure with a loose internal network and thus more permeable samples. However, a critical value has to be overcome in order to guarantee a sufficient viscosity of the dope solution during spinning. These concentration values will result in significant chain entanglement, which aids the formation of dense skin with minimal defects on the hollow fibers (Tai et al., 1997). The HFs prepared at higher dope concentrations present thicker skin layers and more dense substructures, therefore their gas permeation rates are considerably reduced.

In the case of polysulfone HFs the investigated dope concentration was in the range 30–35 wt.%, while the polyimide-based HFs were prepared at a concentration of 24 wt.%. Indeed, the critical concentration for PSf was reported to be 26% (Ismail et al., 2017), whereas for Matrimid a lower value is typically reported at room conditions. Thus, moving from 35 wt.% to 30 wt.% in terms of PSf dope concentration, a three-fold higher gas permeance was achieved, as evidenced in Table 1 for CO₂.

Table 1: Effect of the dope concentration (PSf membranes)

Membrane	Dope conc. (wt.%)	Air gap (cm)	BF/Dope flow rate ratio (-)	CO ₂ Permeance (GPU)
A	35	50	0.8	3.4
B	30	50	0.8	10.1

At fixed dope concentration, an increase in the dope temperature determines a lower viscosity resulting in membranes with a larger permeability, as observed in the case of a lower polymer concentration. In addition, at a high temperature a faster inter-layer diffusion occurs during the phase inversion process. In practice, increasing the dope solution temperature of 10 °C, moving from 60 °C to 70 °C, an almost doubled CO₂

permeance was measured in PSf-based HF as reported in Table 2. In presence of more volatile solvents, high operating temperatures favour also a significant solvent evaporation.

Table 2: Effect of the temperature (PSf membranes)

Membrane	Temperature (°C)	Air gap (cm)	BF/Dope flow rate ratio (-)	CO ₂ Permeance (GPU)
C	60	60	0.6	4.9
D	70	60	0.6	8.7

The presence of a solvent in the bore fluid, delaying the coagulation time and reducing the dope concentration at the interface, can be exploited to modify the structure of the internal skin layer. A change in the bore fluid composition (e.g. a mixture of NMP and water) results in very thin inner skin layers, with a consequent increase of the gas permeance through these HF. In the case of the Matrimid-based HF, the substitution of the water as bore fluid with a mixture of NMP and water (60/40 wt./wt) causes a significant increase in CO₂ permeance from 13.3 GPU to 50 GPU, but partially compromising the selectivity.

After proving the role of the main physical-chemical parameters in spinning process, the effect of engineering nature variables was investigated. A reduction in the air gap was effective in increasing the gas permeance in the case of PSf HF. Thus, reducing the air gap from 60 cm to 50 cm and finally to 6 cm, a progressive increase in CO₂ permeance was measured (Table 3, samples E, A and F). Indeed, varying the air gap, a different membrane microstructure during the spinning since different precipitation paths take place on the extremal surface of the forming HF. At very low air gap distances, the coagulation on the external side is almost instantaneous, producing more open and permeable skin layers. On the contrary, increasing the air gap the combined effect of larger velocity, elongational stresses because of gravity and kinetically slower phase-separation lead to denser and less permeable skin layers on both inner and outer regions of the HF. This effect is particularly evident when the spinning temperature is increased. However, the air gap influence is still more pronounced when a small spinneret is used. Reducing the air gap from 50 cm to 1 cm, an almost three-fold higher CO₂ permeance was measured (Table 3, samples G and H). By using the same spinneret (BF/Dope Cross section ratio = 0.15) and an equiponderal NMP and water mixture as bore fluid, instead of pure water, six times more permeable HF were obtained when decreasing the air gap from 50 cm to 1 cm. In this way, it is possible to favourably couple different effects in a synergistic way.

Table 3: Effect of the air gap (PSf membranes)

Membrane	Air gap (cm)	BF/Dope flow rate ratio (-)	BF/Dope Cross section ratio (-)	CO ₂ Permeance (GPU)
E	60	0.8	0.21	2.3
A	50	0.8	0.21	3.4
F	6	0.8	0.21	4.8
G	50	0.4	0.15	1.2
H	1	0.4	0.15	3.3

In the case of Matrimid, the reduction of air gap from 50 cm to 1 cm caused an increase in HF selectivity, without a significant increase in gas permeance. This is dissimilar than what observed by Clausi and Koros (2000) with a similar polymer, probably due to a different weight of internal and external resistances in a different membrane morphology.

Furthermore, an increase in the bore fluid flow rate results in more permeable HF when the air gap is fixed. Using the same spinneret and flow rates ratio (BF/dope), the higher the flow rates for the dope and the bore fluid, the greater the spinning velocity and therefore the HF gas permeance (Table 4, samples I and L). The lower gas transport resistance arises from thinner dense layers. At the same time, keeping the same flow rates, a smaller spinneret produces more permeable HF owing to larger linear velocities for the dope and bore fluid (Table 4, samples I and M). Therefore, smaller spinnerets should be selected since they produce thinner HF that can be packed in more compact modules, but at the same time are also more permeable. The resulting membranes will cause significant footprint reductions to treat a fixed stream. In these operation conditions, the pretreatment of the feed gas stream is fundamental in order to prevent fiber plugging by impurities.

Table 4: Effect of the flow rates (PI membranes)

Membrane	BF flow rate (g/min)	BF/Dope flow rate ratio (-)	BF/Dope Cross section ratio (-)	CO ₂ Permeance (GPU)
I	3	0.6	0.21	5.1
L	5	0.6	0.21	10.2
M	3	0.6	0.15	12.1

The discussed results highlight the fundamental role of the spinning velocity in order to produce more permeable samples. Similarly, larger air gap distances produce an increase of the spinning velocities, but the predominant role is related to the microstructure evolution due to the solvent-non solvent exchange, as reported before in the discussion associated to Table 3.

The HF spinning, performed with a conventional double orifice spinneret, inevitably causes the formation of two opposite skin layers. Therefore, the resulting HFs present a doubled resistance to the mass transport with a consequent reduction in the gas permeance. The opportunity of suppressing one of these main resistances is significant in order to enhance the productivity.

Indeed as discussed before, a change in the bore fluid composition, by adding a solvent, can be used to suppress the transport resistance located on the inner HF side. However, a thinner internal skin layer can be associated to a compromised selectivity. In this case, the role of the external layer is more important. The resistances in series model indicate that the presence of an external layer with a low selectivity depresses the overall performance besides to reduce the overall gas permeance.

Typically, the external skin layer formed in a conventional spinneret is not completely selective when working at a high air gap in order to increase the spinning velocity.

A suitable approach to reduce the mass transport resistance is the use of a triple orifice spinneret where an additional fluid stream on the external side of the forming HF is involved. When using a triple orifice spinneret, a high air gap height is necessary in order to take advantage of the crucial role of the external fluid. In particular, at a fixed air gap, a solvent-rich external fluid is capable of suppress the mass transport resistance located on the outer side of the membrane, creating a porous surface as confirmed by the SEM analysis (Figure 3). As a result, the permeance is improved (from 13.3 GPU to 22 GPU for CO₂). In addition, the samples produced with the triple orifice spinneret have an enhanced selectivity (up to 35 for CO₂/N₂) owing to a predominant role of the tighter and higher perfect inner layer induced by the big air gap.

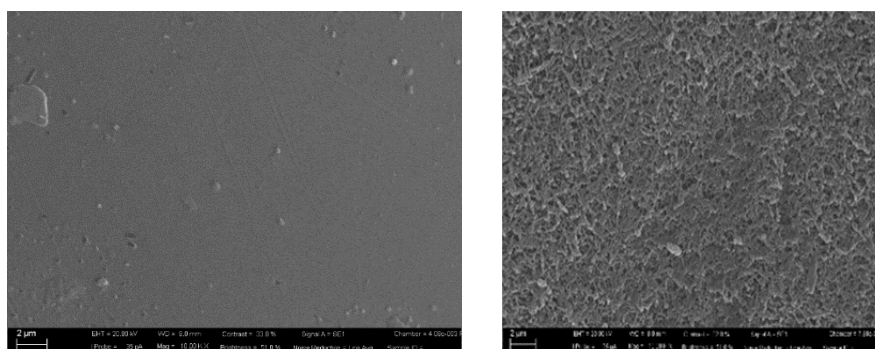

Figure 3: SEM image of the external surface of a Matrimid HF. a) Conventional spinneret; b) Triple orifice spinneret with a solvent-rich external fluid

4. Conclusions

Different batches of asymmetric hollow fibers were spun according to the dry-jet/wet phase inversion process by using commercial glassy polymers. These HF membranes were prepared for gas separation, investigating the role of the main operation parameters that affect the spinning process individually and in synergy.

The permeation data show as the extrusion velocity is an important variable in HF spinning. Higher flow rates for BF and dope allow obtaining more permeable samples as well as small size spinnerets. The dope temperature holds a double role in decreasing the viscosity of the dope solution and favouring the evaporation/exchange of solvent and non-solvent during the phase separation process.

Using a conventional double spinneret, low air gap distances are suggested to increase the gas permeation rates of the hollow fibers.

An advantageous strategy to suppress the external mass transport resistance is the use of triple orifice spinneret using a solvent-rich external fluid, whereas the addition of solvent to the bore fluid is helpful in the reduction of internal mass transport resistance. However, the triple orifice spinneret is able to produce at the same time permeable and selective membranes.

A proper selection of the spinning conditions and spinneret type results in gas separation HF's having thin skin layers, high permeation rates and selectivity coefficients.

Acknowledgments

Huntsman Advanced Materials (Europe) is gratefully acknowledged for providing the Matrimid sample. The authors thank Dr. G. Chiappetta (ITM-CNR) for the SEM analyses.

References

- Bernardo P., Drioli E., Golemme G., 2009, Membrane Gas Separation: A Review/State of the Art, *Industrial and Engineering Chemistry Research*, 48 (10), 4638–4663.
- Bernardo P., Clarizia G., 2013, 30 years of membrane technology for gas separation, *Chemical Engineering Transactions*, 32, 1999–2004.
- Bernardo P., Prete S., Clarizia G., Tasselli F., 2019, Effect of external fluid and inline crosslinking on the performance of polyimide hollow fibres prepared by using a triple-orifice spinneret, *Journal of Membrane Science*, 570–571, 410–417.
- Clarizia G., Bernardo P., Gorrasi G., Zampino D., Carroccio S.C., 2018, Influence of the preparation method and photo-oxidation treatment on the thermal and gas transport properties of dense films based on a poly(ether-block-amide) copolymer, *Materials*, 11, 1326–1342.
- Clausi D.T., McKelvey S.A., Koros W.J., 1999, Characterization of substructure resistance in asymmetric gas separation membranes, *Journal of Membrane Science*, 160/1, 51–64.
- Clausi D.T., Koros W.J., 2000, Formation of defect-free polyimide hollow fiber membranes for gas separations, *Journal of Membrane Science*, 167, 79–89.
- Ismail N.M., Jakariah N.R., Bolong N., Anissuzaman S.M., Nordin N.A.H.M., Razali A.R., 2017, Effect of Polymer Concentration on the Morphology and Mechanical Properties of Asymmetric Polysulfone (PSf) Membrane, *J. Applied Membrane Science & Technology*, 21, 33–41.
- Khayet M., 2003, The effects of air gap length on the internal and external morphology of hollow fiber membranes, *Chemical Engineering Science*, 58, 3091–3104.
- Mulder M., 2003, *Basic principles of membrane technology*, 2nd edition, Kluwer Academic Publishers, Dordrecht, the Netherlands.
- Ortiz C., Valverde J.M., Chacartegui R., Romeo L.M., Perez-Maqueda L.A., 2018, The mOxy-CaL Process: Integration of Membrane Separation, Partial Oxy-combustion and Calcium Looping for CO₂ Capture, *Chemical Engineering Transactions*, 70, 643–648.
- Tai S.C., Teoh S.K., Hu X., 1997, Formation of ultrathin high-performance polyethersulfone hollow-fiber membranes, *Journal of Membrane Science*, 133(2), 161–175.
- Tasselli F., Drioli E., 2007, Tuning of hollow fiber membrane properties using different bore fluids, *Journal of Membrane Science*, 301, 11–18.