

PM₁₀ Emission Classifier

Hemerka Jiří, Braniš Martin, Vybíral Pavel,
CTU in Prague, Faculty of Mechanical Engineering
Technická 4, 166 07 Prague 6, Czech Republic

The contribution brings information on research of a cyclone classifier which samples particles at exhaust gas flow rates in the range of 2 – 5 m³/h and current temperatures in the range 0 – 200°C according to requirements defined by the PM₁₀ fraction.

For experiments a cyclone with a D = 78 mm diameter of the cylindrical part was designed and produced. In standard laboratory conditions on a dust stand the nondimensional relation $Stk_m = f(Re)$ in the range of volume flow rates 2 – 6 m³/h was found. The relation $Stk_m = f(Re)$ shows how the cyclone classification ability given by the value of Stokes number Stk_m for the aerodynamic particle cut size $a_{1,m}$ changes in dependence on the volume flow rate of the gas given by Reynolds number Re .

A subsequent analysis of this relation from the viewpoint of the required achievement of $a_{1,m} = 10 \mu\text{m}$ led to relation $V = f(t)$ in the form of a polynomial of the 2nd degree. According to this relation the required flow rate of dry air through the cyclone V grows from 2,35 m³/h at 0°C to 4,83 m³/h at 200°C.

For a gas different from dry air the use of a cyclone as a PM₁₀ emission classifier a little different relation $V = f(t)$ can be derived analogously as for dry air from the nondimensional relation $Stk_m = f(Re)$ according to functions of density $\rho = f(p,t)$ and viscosity $\eta = f(t)$ for the particular gas.

1. Introduction

Concentrations of fine dust particles in ambient air in the Czech Republic and on a global scale are given in the form of PM₁₀ and PM_{2,5} particle fractions. Contamination of ambient air with fine dust particles, which represents a serious health hazard for the population and its established relation with sources of solid state pollutants, calls for introduction of measurement of emissions with graded sampling – measurement of PM₁₀ and PM_{2,5} fractions – into practical use. Present Czech legislature on air pollution control focused on sources of emissions is concerned only with the emission limits of solid state pollutants, i.e. concentration of all solid state particles without considering their grain size.

The present paper brings information on research of a cyclone classifier which samples particles at current exhaust gas flow rates and a current temperature range in compliance with requirements defined by the PM₁₀ fraction.

2. Concept of Cyclone Classifier

When sampling solid state particles from a carrier gas a particle classifier is inserted between the sampling probe and filter. The task of the classifier is to separate from the sample particle fractions of particular sizes. The basic characteristics of every classifier is the dependance of grade efficiency E on the aerodynamic particle size a_1 – function $E(a_1)$. The level at which a particle is captured with grade efficiency $E = 0,5$ is designated as the cut size $a_{1,m}$. PM_{10} classifier is the classifier, where $a_{1,m} = 10 \mu\text{m}$ and the dependance $E(a_1)$ is in the form of sharp „S“- curve. For emission measurements a cyclone can be used as a classifier where particles are separated by inertial (centrifugal) force.

The cyclone used for the experiments was originally designed at the Faculty of Mechanical Engineering (CTU in Prague) according to requirements from industry as a preseparator of coarse fractions $a > 20 \mu\text{m}$ in samples of emissions in an assumed range of volume flow rates from 3 to 6 m^3/h and gas temperatures up to 200°C . The design utilized available experimental data on the performance of small diameter cyclones for emission measurements (e.g. Smith et al., 1982).

Assessment of the main dimensions of the cyclone separator was based on an assumption that for geometrically similar cyclones the separating ability can be described by function $E = f(\text{Stk})$, where Stk is Stokes criterion which is a decisive parameter for particle separation in cyclones. Stokes criterion for the magnitude of cut size $a_{1,m}$ is defined as

$$\text{Stk}_m = \frac{a_{1,m}^2 1000}{18 \eta} \frac{v_D}{D} \quad (1)$$

where v_D (m/s) is the characteristic velocity in the cylindrical chamber of a cyclone with diameter D expressed by

$$v_D = \frac{4V}{\pi D^2} \quad (2)$$

The concept of the cyclone was based on value of $\text{Stk}_m = 1,05 \cdot 10^{-3}$ given by Smith at al (1982) for a SRI-I type cyclone. From the viewpoint of separation the cyclone was designed for the most unfavourable case in the range of the above flow rates and temperature. The main dimension of the cyclone - cylinder diameter $D = 78 \text{ mm}$ - was determined by calculation from relation (1). The remaining dimensions were derived by geometrical similarity from the original dimensions of the SRI-I type cyclone. The main dimensions of the designed cyclone are apparent from Fig. 1.

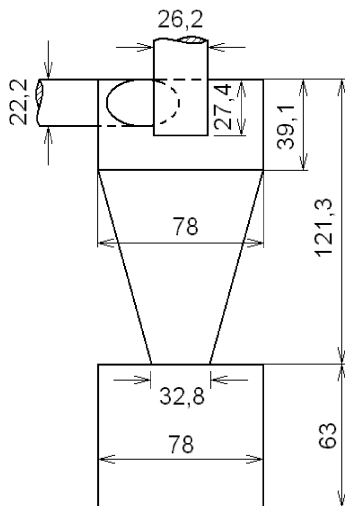

Fig. 1 – Main dimensions of cyclone

Experience with use of cyclone and preliminary laboratory tests indicated, that the cyclone $D = 78$ mm could serve in current conditions of emission measurements as a PM_{10} classifier.

3. Aim of Measurements

In relation with the above requirements in the field of measurement of emissions a proposal was put forward to test if a $D = 78$ mm cyclone would be appropriate for classification of the PM_{10} fraction in a current range of exhausted volume flow rates 2-6 m^3/h in emission apparatuses and temperatures of gases up to $200^\circ C$.

The selected approach was experimental determination of the relation $Stk_m = f(Re)$ and an analysis of this relation from the viewpoint of achievement of $a_{1,m} = 10 \mu m$.

4. Experimental Stand and Measuring Method

Experiments were performed on a 4m long horizontal experimental dust stand with an inner diameter 97 mm. Two variably classified power station fly-ashes with mass medians 9 and 12 μm were used as the experimental media. Concentrations of dust in dependence on the air flow rate through the stand are in the range $0,5 - 2 g/m^3$.

The measurement method of separating ability of the cyclone is based on isokinetic sampling of an aerodisperse mixture from the axis of the channel at a required volume flow rate and subsequent assessment of the total efficiency of separation of the cyclone E_T and assessment of the dependence of the grade efficiency on the size of a particle $E(a)$ on the basis of balance relations on the separator and assessment of the grain size of particles from relevant samples. More detailed information is available in the next

section. A series of experiments performed in the necessary range of volume flow rates makes it possible to determine the nondimensional relation $Stk_m = f(Re)$.

The experimental sampling stand has a standard configuration and comprises a sampling probe with a head, the tested cyclone connected with an end filter equipped with a glass fibre filter, a flow rate measurement device with an orifice plate, a pulse damping vessel equipped with a suction valve and a vacuum pump.

Measurement of relevant quantities and control of the exhausted volume for a variation of the pressure loss of the filter is performed by standard laboratory measurement methods.

5. Method of Assessment of Grade Efficiency

Fig. 2 shows the schematic diagram of a cyclone performing as a solid state particle classifier. Particles entering the cyclone by the inlet are either separated and subsequently captured or pass through the cyclone and leave it by the outlet. Between the inlet, capture section and outlet there are valid simple total and fractional balancing relations.

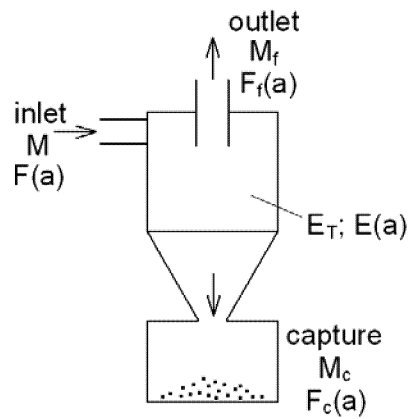

Fig. 2 – Schematic diagram of a cyclone performing as a solid state particle classifier:
 M , M_c and M_f represent total mass flow rates in inlet, capture and outlet
 $F(a)$, $F_c(a)$ and $F_f(a)$ represent oversize cumulative distribution curves

Using the capture – outlet method, the grade efficiency of particles E in the size range $(a, a+\Delta a)$ can be derived as

$$E = \frac{\frac{E_T}{1 - E_T} \Delta F_c}{\Delta F_f + \frac{E_T}{1 - E_T} \Delta F_c} \quad (3)$$

where the total efficiency E_T is defined as a ratio of total mass flows in the capture section and in the inlet and differences of oversize cumulative distribution curves ΔF_c and ΔF_f correspond to particle size difference Δa . Similarly by the inlet - outlet method, i.e. by application of oversize cumulative distribution curves $F(a)$ and $F_f(a)$ for grade efficiency E can be derived as

$$E = 1 - (1 - E_T) \frac{\Delta F_f}{\Delta F} \quad (4)$$

For both relations, i.e. both for the capture-outlet (3) and the inlet-outlet (4) method the following condition is fulfilled – for larger particles where the value ΔF_f first approaches zero, grade efficiency E approaches 1, i.e. to a value theoretically assumed for larger particles for the centrifugal separating principle.

Dust samples for determination of oversize cumulative distribution curves $F_c(a)$ are collected from the discharge hopper of the cyclone, for determination of $F_f(a)$ from the end filter and for $F(a)$ from the dust feed.

Analysis of the grain size of particle samples from the capture section and outlet was performed on a Fritsch Analysette 22 laser analyzer which classifies particles into 62 size intervals ranging from 0,3 to 300 μm and the identified number distribution of particle sizes is recalculated to the required distribution according to mass.

6. Performed Measurements and Results

Within the range of volume flow rates 2 – 6 m^3/h altogether 14 measurements were performed. The measurements performed either by the capture-outlet (3) or inlet-outlet (4) method led to the behaviour of function $E(a)$ in Fig. 3. In the range of fine particles where the grade efficiency should approach zero a certain non-zero value E_{min} was found and for smaller particles the grade efficiency again grew.

This systematic error can be explained by a hypothesis that fine particles with a size below 1 μm are not perfectly dispersed in the feeding device and move along the dust stand in clusters and from the viewpoint of separation behave like coarse particles. However when analyzing particle samples the dust is first adjusted in a supersonic bath and only after being perfectly dispersed the samples are subsequently analyzed. For fine particles the assumption of equality of fractional mass flow rates is not complied with and evaluation of measurements in this range of particle sizes leads to systematic errors.

Limitation of the range of particle sizes starting from which particles in the cyclone are separated can be determined theoretically from the equilibrium of centrifugal force and aerodynamic resistance assuming a simplified model of flow through the cyclone and

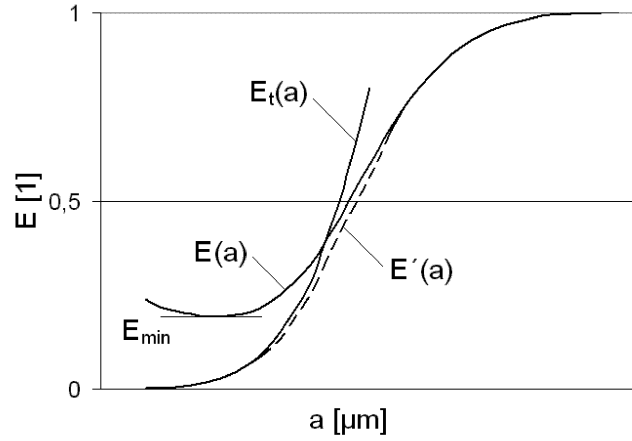

Fig. 3 – Correction of function $E(a)$

quasistationary motion of particles at the separating surface. This simplified model leads to the theoretical behaviour of $E_t(a)$ in the form $E_t = k \cdot a^2$ also shown in Fig. 3. The found behaviour of $E(a)$ for the range of larger particles and the theoretical behaviour of $E_t(a)$ for the range of smaller particles are a basis for plotting corrected function $E'(a)$.

In order to be able to determine the values of cut size $a_{1,m}$ and in general to express the separating ability in the form of aerodynamic particle sizes a_1 the corrected function $E'(a)$ must be recalculated to function $E(a_1)$ according to relation

$$a_1^2 1000 = a^2 \rho_p \quad (5)$$

where ρ_p [kg/m^3] is the particle density.

The method used for evaluation was that in which the value E_{\min} for the found function $E(a)$ (and hence also correction) was minimum. In fact this meant that the capture-outlet method was applied for lower volume flow rates and the inlet-outlet method for higher volume flow rates.

Changes of the separating ability of the cyclone with varying flow rate can be generalized in the form of dependance of Stk_m on Reynolds number Re . In compliance with relation (1) by applying volume flow rate V , the Stokes criterion Stk_m related to the cut size $a_{1,m}$ is expressed in the form

$$Stk_m = \frac{a_m^2 \rho_p}{18 \eta} \frac{v_D}{D} = \frac{a_{1,m}^2 1000}{18 \eta} \frac{v_D}{D} = \frac{a_{1,m}^2 1000}{18 \eta} \frac{4 V}{\pi D^3} \quad (6)$$

and Reynolds criterion Re by applying volume flow rate V is expressed in the form

$$Re = \frac{v_D D}{\nu} = \frac{v_D D \rho}{\eta} = \frac{4 V \rho}{\pi D \eta} \quad (7)$$

In relations (6) and (7) ρ [kg/m³] is the gas (air) density and η [Pa.s] is the dynamic viscosity of the gas (air).

Results of measurements in the form of criteria Stk_m and Re are summarized in the form of dependance of Stk_m on Re in Fig. 4.

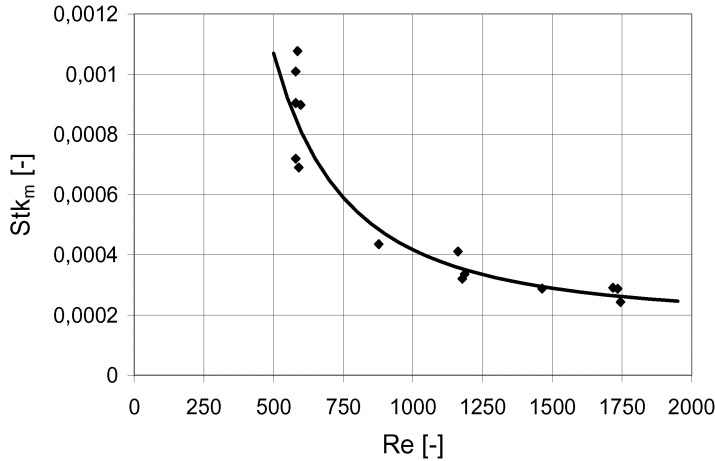

Fig.4 – Dependance of Stk_m on Re

The found dependance of Stk_m on Re can best be expressed by the nondimensional dependance $Stk_m = f(Re)$ in the form

$$Stk_m = 0,00018 + 127 \cdot Re^{-1,91} \quad (8)$$

7. Analysis of Results of Measurements – Cyclone as a PM₁₀ Emission Classifier

Measurement of the grade efficiency of a cyclone generalized in the form given by relation (8) makes it possible to determine for what temperatures and for what flow rates the cyclone $D = 78$ mm can be used as a PM₁₀ emission classifier. If criteria Stk_m and Re in relation (8) are substituted with relations (6) and (7) respectively we obtain

$$\frac{4V}{\pi D^3} \frac{a_{1,m}^2 1000}{18\eta} = 0,00018 + 127 \left(\frac{4V\rho}{\pi D\eta} \right)^{-1,91} \quad (9)$$

In this relation we can observe quantities ρ and η which depend on the composition of the gas. The gas density ρ furthermore depends on state quantities temperature and pressure and the dynamic viscosity η is a function of temperature.

In further processing of results it will be assumed for simplicity that the gas is dry air and current relations will be used for functions $\rho = f(p,t)$ and $\eta = f(t)$. The calculation will be performed for standard pressure 98 kPa in such a way that $a_{1,m}$ is set equal to $10 \cdot 10^{-6} \text{m}$ and by iterating a dependance will be obtained of the volume flow rate of air V on the temperature of air t for which the cyclone can be used at 98 kPa as a PM_{10} emission classifier. The found dependance $V = f(t)$ can be expressed by a polynomial of the 2nd degree in the form

$$V = 7 \cdot 10^{-6} t^2 + 0,011 t + 2,35 \quad (10)$$

8. Conclusion

The nondimensional relation $\text{Stk}_m = f(\text{Re})$ in the form (8) was experimentally determined on a dust stand and shows how the separation ability expressed by Stk_m changes with the volume flow rate expressed by Reynolds number Re .

By analyzing this function it was found that a cyclone with a $D = 78 \text{ mm}$ diameter, in the range of current temperatures of emission measurements $0 - 200^\circ\text{C}$ and current flow rates of the exhausted samples $2 \text{ to } 5 \text{ m}^3/\text{h}$, can be used as a PM_{10} emission classifier. The calculation is performed for dry air and barometric pressure 98 kPa and leads to the function $V = f(t)$ in the form of a polynomial of the 2nd degree – relation (10). According to this relation the required flow rate through the cyclone V increases from $2,35 \text{ m}^3/\text{h}$ at 0°C to $4,83 \text{ m}^3/\text{h}$ at 200°C .

For a different gas than dry air the use of a cyclone as a PM_{10} emission classifier differs from (10) and by an analogous procedure to that with dry air can be derived from relation (9) according to relevant values of $\rho = f(p,t)$ and $\eta = f(t)$ for the particular gas.

9. Reference

Smith, W.B., Parsons, C.T., Wilson Jr., R.R., Harris, D.B.: A Five-Stage Cyclone System for Measuring Particle Size and Concentration in Process Streams, *Journal of Aerosol Science*, 13, No. 3, 1982, pp. 217 – 219.

Acknowledgement

The above research is an item of the Czech Research Plan MSM674077011 "Environmental Technology".