

Deposition of nanoparticles in the walls of the sampling ducts

Simone A. Pozza¹, Edson R. Nucci², José R. Coury³
si_pozz@yahoo.com.br¹, edsonucci@gmail.com², jcoury@ufscar.br³
Universidade Federal de São Carlos, Departamento de Engenharia Química
Telefone +55 16 33518944 Rodovia Washington Luís km 235 CEP 13565-905
São Carlos - SP - Brasil

The aim of the present work was to investigate the influence of operational variables in the nanoparticle loss to the duct walls, for nanoparticle laden aerosols. Several tests were carried out changing the aerosol flow rate, the tube diameter and the tube length. The effect of these variables in the total number of particles and in the median particle diameter after the tube was measured using the SMPS (Scanning Mobility Particle Sizer) particle analyzer. The results showed considerable loss to wall for particles smaller than 100 nm. Also, disagreement between theory and experiment occurs in this size range, indicating that the understanding of the mechanism of particle deposition needs further investigation.

1. Introduction

Study of transport and deposition of aerosols has attracted considerable attention due to its importance in numerous industrial and technical applications (Zhang & Ahmadi, 2000). Whatever the purpose of the generation of nanoparticles, their production and re-suspension in gas streams constitutes a complex process, although increasingly necessary. To be industrially relevant, the process must be low cost and involve the possibility of continuous operation and high production of particles. In the vast number of industrial processes and technology involving the generation of nanoparticles, the latter are usually required as an aerosol. The sizing of nanoparticles present in aerosols, inevitably, involves sampling and transport of the solid suspension, usually through tubing. In this study, we consider deposition of nanoparticles on the wall of a small cylindrical duct. This is particularly important for the evaluation of aerosol sampling.

2. Materials and Methods

The SMPS equipment included an electrostatic classifier (model 3080, TSI Inc.) coupled to a LONG-DMA (model 3085, TSI Inc.) and an Ultrafine Condensation Particle Counter (UCPC, model 3776, TSI Inc.).

Aqueous sodium chloride (NaCl) solutions with density of 2.165 g/cm³ were used in the tests at concentrations of 0.50 g/L. This solution was dispersed and dried in the form of aerosols with particle diameter ranging from 8 to 250 nm. The tests were performed

with the nanoparticle loaded aerosol being directed through a desiccating column with silica gel (diffusion dryer) to ensure complete drying and removal of excess moisture, followed by charge neutralization (with Kr-85). The device was equipped with an isokinetic sampling nozzle that directed the aerosol to the SMPS spectrometer. A nanoparticle generation nozzle was built specifically for this study and is shown in Figure 1, where the dashed area shows the mainly area of the present study.

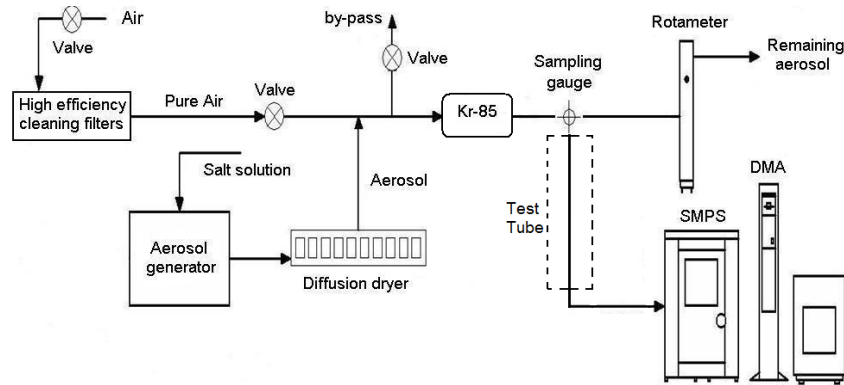

Figure 1 – Scheme of the experimental unit.

The deposition in the duct was evaluated by sampling the aerosol in the duct entrance and exit. The aerosol not sampled was discarded. Three replicates for each test were made.

This work follows a previous study was carried out by Nucci *et al.* (2010). The influence of the aerosol flow rate (F), the tube diameter (d) and the tube length (L) was studied using a 2^3 full factorial design. Several experiments were made, varying the tube length (L) and diameter (d) and the aerosol flow rate (F), as shown in Table 1.

Table 1. Matrix of the experimental tests used in the present work.

Experiments	L (m)	F (L.min ⁻¹)	d (mm)
P ₁	1.16	10.00	6.34
P ₂	2.84	10.00	6.34
P ₃	2.00	6.64	6.34
P ₄	2.00	13.36	6.34
P ₅	2.00	10.00	3.68
P ₆	2.00	10.00	9.01
P ₇	2.00	10.00	6.34

In the previous work the application of statistical design (Dias *et al.*, 2001) was used to determine the optimum operating conditions for the system and the results showed that total number of particles counted by the SMPS depend on the tube length and diameter, whilst the particle median diameter was strongly dependent on the tube diameter. These previous results indicated the level of the variables to be used here.

3. Particle deposition

Particle deposition was experimentally evaluated by measuring the number of particles in the duct entrance and exit, as a function of particle diameter in the range of 8 to 200nm. For this, the particle concentrations were measured before and after the tubes. Particle deposition in the walls was expressed in terms of the experimental efficiency η defined in Eq. 1:

$$\eta = 1 - \frac{C_o}{C_i} \quad (1)$$

where C_i and C_o are the particle concentration in and out, respectively. The experimental values were compared to theoretical correlations found in the literature. The classical work by Ingham (1975) presents an analytical solution for particle deposition in cylindrical tubes based on particle diffusion alone. The aerosol flow was assumed uniform and two cases were considered: flat velocity profile and parabolic profile. The respective correlations for the efficiency of deposition η were given by:

$$\eta = \frac{8}{\sqrt{\pi}} \Delta^{\frac{1}{2}} - 4\Delta \quad (2)$$

$$\eta = 1 - 0.819 \exp(-14.6\Delta) - 0.098 \exp(-89.2\Delta) - 0.033 \exp(-228\Delta) - 0.051 \exp\left(-125.9\Delta^{\frac{1}{2}}\right) \quad (3)$$

In these equations, the dimensionless diffusion parameter Δ is defined as DL/Ud^2 , where, D is the Brownian diffusion coefficient, L is the duct length, d its diameter and U is the aerosol mean velocity.

Zhang and Lessmann (1997) extended Ingham's approach to other duct geometries and, for uniform flow in circular ducts with flat velocity profile, suggested:

$$\eta = 8\beta\Delta^{1/2} - 16\beta^2\Delta \quad (4)$$

where β is a constant with an arbitrary value of 0.65.

4. Results

Several tests were carried out varying the aerosol flow rate, the tube diameter and the tube length. The efficiency of deposition of nanoparticles in the wall of tubes was calculated and Figures 2a, 2b and 2c illustrate the results.

It can be noticed that, in all tests, low efficiencies (hence small deposition) occurred. Nevertheless, for particle diameter smaller than approximately 100nm, the deposition increases sharply. This behavior qualitatively indicates that Brownian diffusion plays an important role in the particle loss to wall.

Effect of the tube diameter d

Figure 2a shows the effect of the tube diameter d in the particle deposition. In these tests, the tube length and aerosol flow rate were kept constant ($L= 2.00$ m; $F= 10.00$ l/min), whilst three tube diameters were used ($d= 3.68$, 6.34 and 9.01 mm). The results show that, for particles above 120 nm, the deposition fluctuates around 20% , and the tube diameter has little effect on it. Conversely, for article diameters below 120 nm, the deposition increases sharply and the results show a clear dependence on d : as the tube diameter decreases, so does the particle deposition. It is important to notice that smaller tube diameters, at constant flow rates, means higher aerosol velocities (and, therefore, smaller residence times), not favoring deposition. On the other hand, smaller diameters mean thinner channels, favoring Brownian deposition. The latter seems to predominate here.

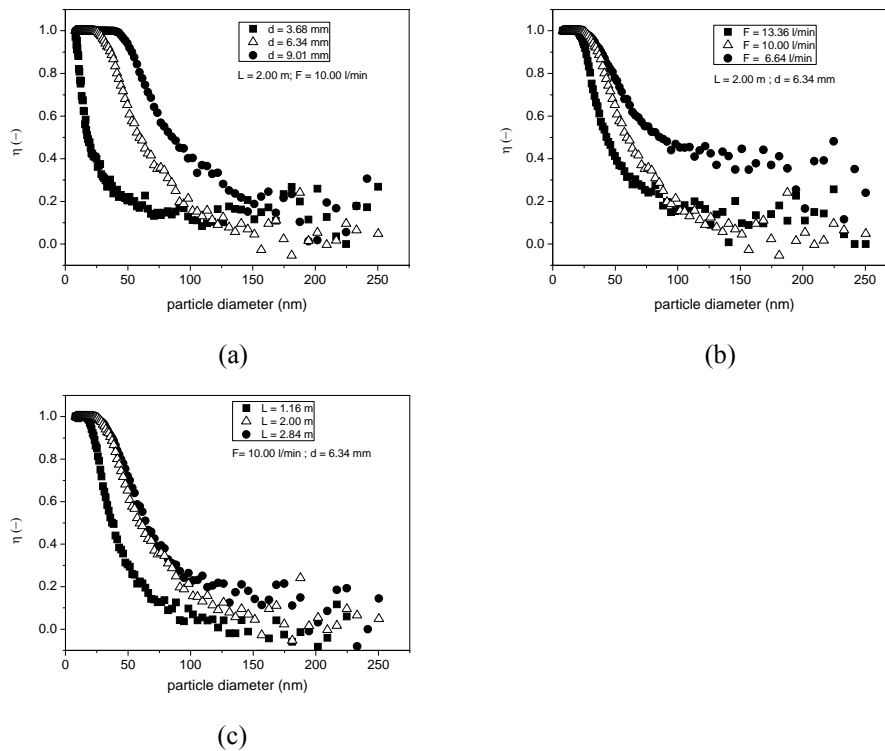

Figure 2 Experimental efficiency of nanoparticle deposition: (a) efficiency with diameter as variable; (b) efficiency with aerosol flow rate as variable and (c) efficiency with tube length as variable.

Effect of the aerosol flow rate F

Figure 2b shows the effect of the aerosol flow rate F in the particle deposition. In these tests, the tube length and diameter were kept constant ($L= 2.00$ m; $d= 6.34$ mm), whilst three aerosol flow rates were used ($F= 6.64$, 10.00 and 13.36 l/min). The results show that, for particles above 100 nm, the deposition tend to stabilize, with higher deposition

for $F= 6.64$ l/min. For particle diameters below 100 nm, the deposition increases sharply and the results show a clear dependence on F : as the aerosol flow rate decreases, an increase particle deposition is observed. In this case also, the increase in F means a decrease in the residence time, not favoring deposition. But in this case, d is constant and its effect on the Brownian diffusion is not present. Therefore, the observed trend seems to be due to residence time alone.

Effect of the tube length L

Figure 2c shows the effect of the tube length L in the particle deposition. In these tests, the tube diameter and aerosol flow rate were kept constant ($d= 6.34$ mm; $F= 10.00$ l/min), whilst three tube lengths were used ($L= 1.16, 2.00$ and 2.84 m). The results show that here again, for particles above 100 nm the deposition fluctuate around 20%, and the tube length has little effect on it. Conversely, for article diameters below 100 nm, the deposition increases sharply and the results show a clear dependence on L : as the tube length decreases, so does the particle deposition. In this case, the results confirm the obvious: the shorter the tube, the smaller the deposition.

Experimental vs. theory

Figure 3a shows the theoretical predictions calculated from equations 2 to 4, for the particle deposition efficiency for the conditions of experiment P1 (see Table 1), taken as typical. It can be noticed that, qualitatively, the curves are similar to the experimental results: the efficiency is small for the bigger particles and increases sharply as the particle size decreases. This confirms the Brownian diffusion play a very important role in the deposition. The Figure 3a also shows that all three equations provide similar results, with equation 3 giving slightly higher deposition than the others. When compared to the experimental results, these predictions underestimate the particle deposition.

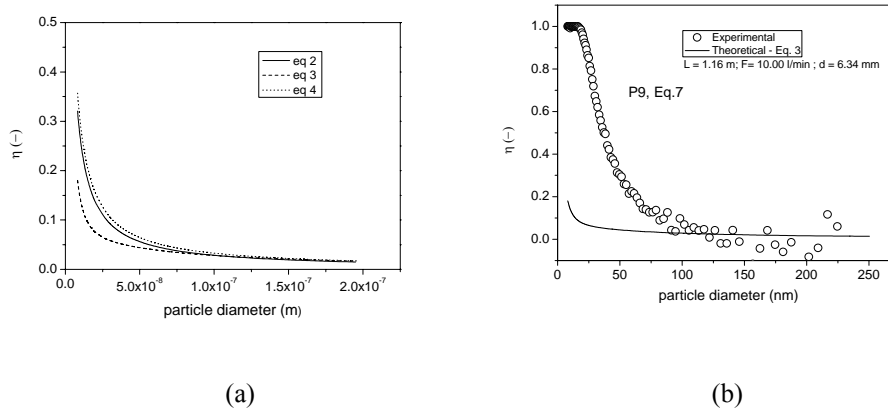

Figure 3 (a) Theoretical efficiency calculated from equations 2 to 4, for the conditions of experiment P1; (b) Comparison between experiment and theory (Eq 3) for the same conditions P1.

Figure 3b shows a comparison between the experimental results and the theoretical prediction, based on equation 3, for the experimental conditions of experiment P1. It clearly shows that, for particles bigger than 100nm where deposition is weak, the theoretical prediction represents fairly well the experimental points. However, for $d_p < 100$ nm, the experimental efficiency decreases faster than predicted. This same trend appears in all the other tests. This indicates that further work is necessary regarding the theory. Some elements are noticeable: the theoretical assumption of uniform flow is not strictly applicable here, as the Reynolds number covered in the tests varied between 1.2×10^3 and 3.2×10^3 ; also, the diffusion coefficient D was estimated utilizing the classical Cunningham's slip factor, and its validity for Knudsen numbers of the order of unity or higher is questionable (Li & Wang, 2003).

5. Conclusion

The results showed considerable the tube length (L) and diameter (d) as well as aerosol flow rate (F) can have a strong influence in the size distribution of sampled nano-aerosols, due to particle loss to the sampling duct. This effect is particularly stronger for particles below 100 nm, where some correction must be made. Comparison of the experimental results with a classical correlation from the literature shows that further theoretical work is necessary on the matter.

References

- Ingham, D. B., 1975, Diffusion of aerosols from a stream flowing through a cylindrical tube. *J. Aerosol Sci.* 6, 125-132.
- Dias, M.A.; Rosa, C.A.; Linardi, V.R.; Conte, R.A.; Castro, H.F., 2001, Application of Factorial Design to Study of Heavy Metals Biosorption by Waste Biomass from Beverage Distillery. *Applied Biochemistry and Biotechnology*, v.91-93, p.413-422.
- Li, Z. & Wang H., 2003, Drag force, diffusion coefficient, and electric mobility of small particles. I. Theory applicable to the free-molecule regime, *Physical Review E*, The American Physical Society, v. 68, p.061206-1 – 11.
- Nucci, E. R., Pozza, S. A., Barros, A. N. C., Coury, J. R., 2010, Nanoparticle deposition in tubes: statistical study using the response surface methodology. 19th International Congress of Chemical and Process Engineering (CHISA 2010). Prague, Czech Republic. 9p.
- Zhang, H. & Ahmadi, G., 2000, Aerosol particle transport and deposition in vertical and horizontal turbulent duct flows. *J. Fluid Mech.* 406, 55-80.
- Zhang, Z. & Lessman, R., 1997, A unified lagrangian trajectory model for particle diffusion in ducts. *J. Aerosol Sci.* 28 (4), 635-642.