

Methanol Synthesis: a Distributed Production Concept Based on Biogas Plants

Daniele Previtali^a, Antonio Vita^b, Andrea Bassani^a, Cristina Italiano^b, André Furtado Amaral^a, Carlo Pirola^c, Lidia Pino^b, Alessandra Palella^b, Flavio Manenti^a

^a Politecnico di Milano, Dipartimento di Chimica, Materiali e Ingegneria Chimica "G. Natta", Piazza Leonardo da Vinci 32, 20133 Milano, Italy

^b CNR-ITAE, Institute for Advanced Energy Technologies "Nicola Giordano", Via Salita S. Lucia Sopra Contesse 5, 98126, Messina, Italy

^c Università degli Studi di Milano, Dipartimento di Chimica, Via Golgi 19, 20133 Milano, Italy
flavio.manenti@polimi.it

Today biogas produced from anaerobic digestion is used mainly for thermic and electric energy production. Its use as raw material for syngas production and further upgrading to chemical products like methanol (MeOH), dimethyl ether (DME) or acetic acid could be an interesting option as process intensification. In this work the sustainability of a Biogas-to-MeOH (BtoMeOH) or Biogas-to-DME (BtoDME) process was studied. The biogas feedstock of the Combined Heat, Power and Chemicals (CHPC) is equivalent to the production of 1 MWe in a Combined Heat and Power Plant (CHP). Biogas is converted using a reformer into syngas to produce methanol. The plant was designed considering mild conditions for chemical production and the energy necessary to reactors was generated using a fraction of the inlet biogas. This process was studied using the Simulation Suite PRO/II[®] by Schneider-Electric Simulation Science. The reformer and the methanol reactor productivity were evaluated with the experimental data obtained through bench scale plants. An economic analysis was performed to assess the sustainability of these new processes, capital and operative costs of the plants were evaluated using the Guthrie's method. The Biogas-to-MeOH process can produce up to 297 kg h⁻¹ of methanol with recycle. The biogas necessary to supply the energy demand of the plant is 192 kg h⁻¹, a third of the inlet feedstock. For the Biogas-to-DME process the energy demand is similar while the DME production is 173 kg h⁻¹. The preliminary economic evaluation shows that the main item for the capital costs are reactors and compressors and the breakeven point of both processes is 3 years. Despite the lower productivity, DME process is more convenient due to a higher market value.

1. Introduction

Biogas is a mixture of several gases produced by anaerobic digestion of organic matter. The raw organic material could be farm and agricultural waste, sewage, municipal waste and plant material. Typically, methane is the main component of biogas followed by carbon dioxide and other substances present in lower percentage (Table 1) (Ryckebosch et al., 2011).

In the European Union, the biogas production is 15.6 Mtoe in 2015 and 77 % of this is concentrated in Germany (7.9 Mtoe), UK (2.3 Mtoe) and Italy (1.9 Mtoe). The main use of biogas is the electrical and heat production using Combined Heat and Power plants (CHP) while the upgrading to biomethane and injection into natural gas grid or use as automotive fuel is disadvantaged due to additional purification treatments and lower incentives.

This is apparent especially in Italy, which produces 12.2 % of European biogas but has only 1% of European plants for the upgrading to biomethane (EurObservER, 2016). Biogas and biomethane are considered green fuels since the quantity of released CO₂ in the entire life-cycle is almost zero but from an environmental point of view another process could be more interesting, the Combined Heat Power and Chemical (CHPC). The CHPC process, in addition to electrical and heat energy, converts biogas into valuable biochemicals like methanol (MeOH), dimethyl ether (DME), acetic acid (AA) and others which, differently from biogas and

biomethane, are easier to transport, with a higher added value and make effective the CO₂ utilization. Differently from CHP concept, where methane is converted to CO₂ through combustion process and CO₂ is released back to the atmosphere, in CHPC plant, both the methane and CO₂ parts are transformed into biochemicals. In practice, the relevant portion of CO₂ (40%vol, but about 70%w) is not released back to the atmosphere, but it enters the chemical bonds of the produced molecules.

Methanol is one of the most important chemicals and it is used as solvent, fuel and starting material to produce formaldehyde, methyl-tert-butyl ether (MTBE), acetic acid and dimethyl-ether (DME) (Bozzano et al., 2016). Its production is continuously growing in last years reaching 70 Mt in 2014 and with a forecast demand of over 100 Mt in 2020 (Alvarado, 2016). Methanol is produced starting from syngas, a mixture of hydrogen and carbon monoxide, in presence of a copper-based catalyst (Chinchen et al., 1988). The operative conditions depend on technologies and catalyst used, typically modern industrial plants operate at 230-250°C and 40-100 bar (Manenti et al., 2014). Another interesting chemical is DME which is considered one of the most interesting alternative future fuels (substitute for LPG) due to lower emissions and higher performance respect to diesel fuel (Maji et al., 2015). It can be synthesized in two ways: indirectly (Xu et al, 1997), from methanol dehydration or directly, starting from syngas (Kim et al., 2004). The second case is the most interesting since combine the methanol production and its dehydration in a single step reactor, improving conversion and decreasing costs (Azizi et al., 2014). Also, systematic staging optimization studies have been performed to optimize the DME synthesis (Manenti et al., 2013).

The base idea broached in this work is to assess preliminarily technical and economic feasibility and appeal of a compact methanol production plant, which could be placed downstream the existing biogas plants in a non-invasive way (no modifications required on the existing plants). This compact methanol production plant can be replicated on different biogas plants to achieve the on-spec bulk production of methanol in dedicated geographical areas; this concept is in clear contrast with the traditional value chain of large biorefineries. Chief benefits are: (i) the CAPEX investment is not any longer centralized on the single plant, but it is shared on many plants making the solution appealing to the farms; (ii) the yield is conceptually competitive with the one of traditional biorefinery.

Table 1: Typical biogas components and composition.

Compound	MIN [%vol]	MAX [%vol]
CH ₄	40	70
CO ₂	15	60
H ₂ O	0	10
H ₂ S	0.005	2
Siloxanes	0	0.02
VOC	0	0.6
NH ₃	0	1
O ₂	0	1
CO	0	0.6
N ₂	0	2

2. Experimental activities

The Biogas-to-Methanol (BtoMeOH) and Biogas-to-DME (BtoDME) processes were simulated using a steady-state simulation software, PRO/II[®] 10.0 by Schneider-Electric. We used SRK (Soave-Redlich-Kwong) equation of state as thermodynamic model. The size of the plant was selected considering the average European CHP plant scale of 1 MWe, equivalent to 563 kg h⁻¹ of ideal biogas stream containing 60%vol methane and remaining 40%vol carbon dioxide. The complete flowsheet of the simulated plant is reported in Figure 1.

Not all the fed biogas is converted to methanol, a part is burnt to provide the heat necessary to reformer reactor so as to achieve the energy self-sustainability of the BtoMeOH/BtoDME process. For this reason, biogas is initially split in two streams, one sent to a burner (S1.2) for thermal heat production, whereas the second part (S1.1) is compressed up to 27 bar, mixed with steam, heated up to 800°C and fed to reformer. In the reformer reactor two main reactions take place, the steam reforming and the dry reforming:



Since both the reactions are endothermic the heat is provided burning part of the biogas. The flowrate ratio between stream S1.1 and S1.2 depends on reformer heat demand, the quantity of biogas sent to furnace is the lowest possible. The model used for reforming process was validated with experimental data obtained using a micro-scale plant (Vita et al., 2017). Products are mainly syngas, unreacted methane and carbon dioxide. Hot gases are cooled to 250°C and sent to the methanol reactor where the alcohol is produced by hydrogenation of carbon monoxide and carbon dioxide. In the reactor a third reaction take place, the Reverse Water Gas Shift reaction (RWGS). It is a side reaction which consumes part of the hydrogen and produces water reducing the methanol concentration in the liquid product.



The methanol reactor performance was validated using experimental data obtained with a lab-scale plant. Since the methanol synthesis is an exothermic reaction, the temperature is controlled using cooling water. The methanol reactor is composed by four different catalytic section in series and methanol is removed by condensation after each one in order to increase conversion shifting the chemical equilibrium to products (Manenti, 2015). After the reacting section products are cooled and unreacted gases separated by flash. Part of the gases are recycled and the rest purged.

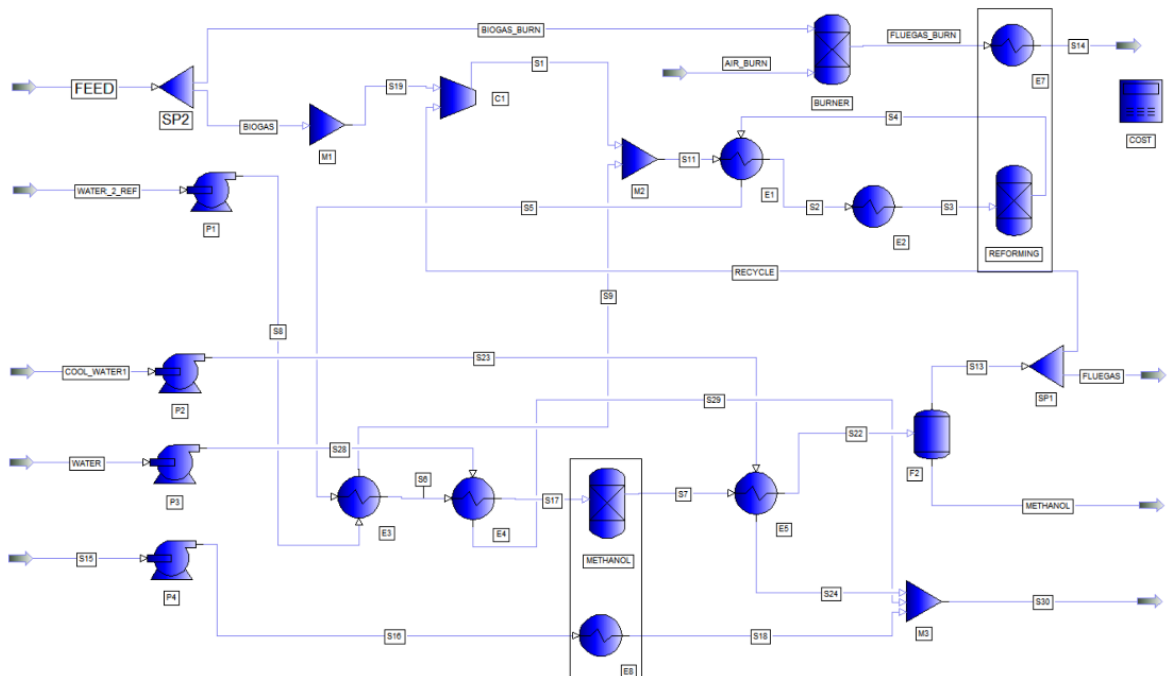

Figure 1: Biogas-to-Methanol process layout.

The economic evaluation was performed implementing in PRO/II a special code (MILANO™ language, SimSci 2016) that calculates both the capital (CAPEX) and the operative costs (OPEX) for each unit. The assessment was done using the Guthrie's method (Guthrie, 1969 and 1974). This costing technique evaluate the cost of an equipment starting from the purchased cost of the same equipment at base conditions and correcting it with different multiplying factor. The final cost is function of several features (specific equipment type, operative pressure, construction materials, etc.). (Turton et al., 2012).

Cost of each equipment was calculated with equation 1:

$$C_{BM} = C_p^0 (B_1 + B_2 F_M F_P) \quad \text{Eq.1}$$

where C_p^0 is the cost of the module at base conditions, B_1 and B_2 are the bare module factor constant, F_M is the material factor for the equipment and F_P is the pressure factor. The module cost at base condition (C_p^0) was calculated using equation 2:

$$\log_{10}C_p^0 = K_1 + K_2 \log_{10}(A) - K_3(\log_{10}(A))^2 \quad \text{Eq.2}$$

in which K_1 , K_2 , and K_3 are tabulated parameters of the equipment unit considered, while A is the capacity (i.e. volume for tanks, active area for heat exchanger, power for compressor and pumps, duty for reformer). We consider stainless steel as construction material for all the equipment. The pressure factor was calculated using equation 3:

$$\log_{10}F_P = C_1 + C_2 \log_{10}(P) - C_3(\log_{10}(P))^2 \quad \text{Eq.3}$$

where C_1 , C_2 and C_3 are tabulated parameters of different equipment and P is the pressure, bar gauge or barg (1 bar = 0 barg). The F_P value is 1 for compressors at any pressure, while for heat exchangers is 1 only when the operative pressure is lower than 40 barg. We reported in table 2 the equipment constants used for the CAPEX estimation.

Table 2: Equipment parameters used for the CAPEX calculation

Equipment	K_1	K_2	K_3	C_1	C_2	C_3	B_1	B_2	F_M	F_{BM}	A
Pump	3.3892	0.0536	0.1538	-0.3935	0.3957	-0.0226	1.89	1.35	2.25	-	kW
Heat Exchanger	3.3444	0.2745	-0.0472	0	0	0	1.74	1.55	2.5	-	m ²
Compressor	5.0355	-1.8002	0.8253	0	0	0	-	-	-	5.8	kW
Reformer	3.0680	0.6597	0.0194	0.1405	-0.2698	0.1293	2.25	1.82	3.1	-	m ³

We consider water, steam and electrical energy as operative cost (Table 3) (Turton, 2012). The price of methanol was set equal to 380 € t⁻¹ (Methanex, 2018). The annual operating time was assumed to 7920 hours.

Table 3: Utilities cost used for the OPEX calculation

Utility/Consumable	Description	Value
Steam for boilers	Latent heat only, Medium pressure (10 barg, 184°C)	14.83 \$ GJ ⁻¹
Cooling water	Water at 20°C	0.354 \$ GJ ⁻¹
Other water	High-purity water for process use	0.067 \$ kg ⁻¹
Electrical energy	-	16.8 \$ GJ ⁻¹

All costs were actualized to 2016 using CEPCI index. The average life-time of equipment in a chemical plant is 9.5 years without salvage value (Turton, 2012) so we consider a depreciation time of 9.5 years.

3. Results and Discussion

The simulation shows that starting from 563 kg h⁻¹ of biogas the BtoMeOH process can produce up to 297 kg h⁻¹ of methanol. 193 kg h⁻¹ (one third) of the fed biogas is burnt to sustain the reforming process. The methanol composition in the product stream is higher than 0.95, so further separation system could be necessary to obtain methanol at high purity. The process has a cost near to 1.4 M\$ with an annual income of about 600,000 \$. The payback time of this process is approximately 3 years. As expected, capital cost mainly depends on compressor (39%) and reactors (42%). In Figure 2 is reported the weight of the different units on the overall CAPEX.

CAPEX of Biogas-To-MeOH

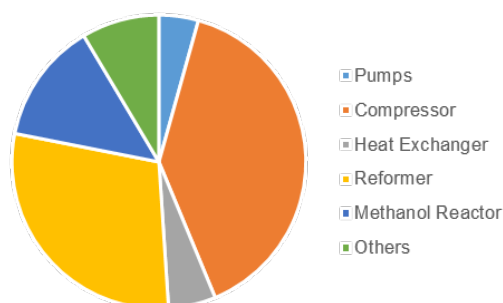

Figure 2. Weight of different units on the capital costs of Biogas-To-MeOH process

Electricity and cooling water are responsible of the 70% of the operative costs. The same plant could be used for the direct synthesis of DME changing only the type of catalyst. In this case the overall carbon conversion increase because the methanol produced in the reactor is directly consumed forming dimethyl ether, and the equilibrium of the methanol reactions is shifted to products. The BtoDME process can produce 260 kg h^{-1} of DME starting from 563 kg h^{-1} of biogas. Differently from methanol, DME separation from unreacted gases is more difficult due to its physical characteristic. For this reason, maintain the same process scheme, after a flash separation the DME flowrate drops to 173 kg h^{-1} . A second flash separation, at low pressure, could be useful to remove residual water and obtain a DME stream with a composition higher than 95%. The capital cost of the Biogas-To-DME and Biogas-To-Methanol process are similar. DME production is more expensive due to the larger quantity of cooling water demand. Nevertheless, since DME price is higher than methanol one, the annual income is larger, about 700,000 \$.

Due to the profitability of these processes, the use of Combined Heat and Power plant (CHP) instead of Combined Heat Power and Chemicals plant (CHPC) could be a new interesting use of biogas. Several small plants, in a delocalized production system, should allow to produce methanol avoiding the use of fossil fuel. The use of CHPC plant could decrease emissions because methane is not burnt and part of the CO_2 is not emitted but converted in chemicals. CHPC could allow to sequester between 2.5 and 3.2 Mt of CO_2 per year. Finally, since the same CHPC plant can produce methanol or DME, the production could be changed in order to optimized revenues in function of the market price of each chemical.

4. Conclusions

In this work a first economic evaluation of Biogas-To-MeOH and Biogas-To-DME process was performed. The plant is the same for both the processes and optimized for methanol synthesis. The CHPC plant size was chosen considering a biogas consumption equal to 593 kg h^{-1} , corresponding to 1 MWe CHP plant. The capital cost is near to 1.4 M\$ and the payback time around 3 years. Productivity of methanol is 297 kg h^{-1} while, for DME, is equal to 173 kg h^{-1} . Despite the lower production, the BtoDME process has a larger profitability due to the higher DME market value. Compared with traditional CHP plant, CHPC has a negative CO_2 impact since carbon dioxide is partially converted into chemicals. A more detailed study of this process could be interesting to better evaluate the feasibility of delocalized production system for methanol and DME. Moreover, the synthesis of other chemicals, like acetic acid, should be assessed.

Acknowledgments

Authors gratefully acknowledge the financial support from Fondazione CARIPO (Project "BioMAN: Bio-revaluation of the Chemical District of Mantova by Planning Non-Food Biomass Supply and its Upgrading to Bio-Products, Program: Fondazione CARIPO"; Project "Cheese-industry Waste to added-value compounds and Bio-materials: an integrated biorefinery (CoWBoy), Program: Fondazione CARIPO")

Reference

- Alvarado M., 2016, The changing face of the global methanol industry, IHS Chemical Bulletin, 3
- Azizi Z., Rezaeimanesh M., Tohidian T., Rahimpour M., Dimethyl ether: A review of technologies and production challenges, Chemical Engineering and Processing: Process Intensification, 82, 150-172, DOI: 10.1016/j.cep.2014.06.007
- Bozzano G., Manenti F., 2016, Efficient methanol synthesis: Perspectives, technologies and optimization strategies, Progress in Energy and Combustion Science, 56, 71-105, DOI: 10.1016/j.pecs.2016.06.001
- Chinchen G., Denny P., Jennings J., Spencer M., Waugh W., 1988, Synthesis of Methanol: Part 1. Catalysts and Kinetics, Applied Catalysis, 36, 1-65, DOI: 10.1016/S0166-9834(00)80103-7
- EurObserv'ER Report, 2016, The State of Renewable Energies in Europe
- Guthrie K.M., 1969, Capital cost estimating, Chemical Engineering, 76, 114-142
- Guthrie, K.M. Eds., 1974, Process Plant Estimating, Evaluation and Control, Craftsman Book Company, Solana Beach, USA
- Kim J., Park M., Kim S., Joo S., Jung K., 2014, DME synthesis from synthesis gas on the admixed catalysts of Cu/ZnO/Al₂O₃ and ZSM - 5, Applied Catalysis A: General, 264, 37 - 41, DOI: 10.1016/j.apcata.2003.12.058
- Manenti, F., Leon-Garzon, A.R., Bozzano, G., 2013, Energy-process integration of the gas-cooled/water-cooled fixed-bed reactor network for methanol synthesis, Chemical Engineering Transactions, 35, 1243-1248
- Manenti, F., Leon-Garzon, A.R., Ravaghi-Ardebili, Z., Pirola, C., 2014, Systematic staging design applied to the fixed-bed reactor series for methanol and one-step methanol/dimethyl ether synthesis, Applied Thermal Engineering 70(2), 1228-1237, DOI: 10.1016/j.applthermaleng.2014.04.011
- Manenti, Processo di conversione del biogas, 2015, patent: "102017000073797, 2017"
- Maji S., Ahmed S., Siddiqui W., Aggarwal S., Kumar A., 2015, Impact of Di-methyl Ether (DME) as an Additive Fuel for Compression Ignition Engine in Reduction of Urban Air Pollution, American Journal of Environmental Protection, 32, 48-52, DOI:10.12691/env-3-2-2
- Methanex, 2018, Methanex Monthly Average Regional Posted Contract Price History, <<https://www.methanex.com/our-business/pricing>> accessed 01.01.2018
- Ryckebosch E., Drouillon M., Vervaeren H., 2011, Techniques for transformation of biogas to biomethane, Biomass and Bioenergy, 35, 1633-1645, DOI: 10.1016/j.biombioe.2011.02.033
- SimSci, PRO/II® 10.0 User Guide, 2016
- Turton R.C., Bailie R.C., Whiting W.B., Shaeiwitz J.A., Bhattacharyya D., Fuller J. Eds., 2012, Analysis synthesis, and design of chemical processes fourth ed., Prentice Hall, Malloy in Ann Arbor, USA
- Vita A., Italiano C., Previtali D., Fabiano C., Palella A., Freni F., Bozzano G., Pino L., Manenti F., 2018, Methanol synthesis from biogas: A thermodynamic analysis, Renewable Energy, 118, 673-684, DOI: 10.1016/j.renene.2017.11.029
- Xu M., Lunsford J., Goodman W., Bhattacharyya A., Synthesis of dimethyl ether (DME) from methanol over solid-acid catalysts, 1997, Applied Catalysis A: General, 149, 289-301, DOI: 10.1016/S0926-860X(96)00275-X