

Potential and Limits of IoT for Hazardous Job in Process Industries

Paolo Bragatto^a, Luca Faramondi^{b,*}, Francesco Failla^b, Maria Grazia Gnoni^c

^a Department of Technological Innovations, INAIL Italian Workers Compensation Authority, Monteporzio Catone, Rome, Italy

^b Unit of Automatic Control, University Campus Bio-Medico di Roma, Via Alvaro del Portillo 21, 00128, Rome, Italy

^c Department of Innovation Engineering, University of Salento, Via Monteroni, 73100, Lecce, Italy

l.faramondi@unicampus.it

In process industries, including refineries, petrochemical plants, air fractioning plants, Oil and gas depots, there are many hazards for workers (both for employees and contractors). Occupational Hazards include thermal extremes, high concentration of toxic or flammable gas and low concentration of oxygen. These hazards are usually controlled by means of procedures, operating instruction, gas sensors, alarms, personal and collective protection equipment. Whilst a few hazards are well known and localized inside the plants, for instance the classified confined spaces or the classified ATEX areas, in other cases, hazards are associated to a high uncertainty, hence, it's difficult to find a trade-off between the precautionary safety requirements and the work practicality and easiness. The worker, moreover, must be protected, when the hazard is present but cannot be overwhelmed by heavy protection or oversize solution. The potential of IoT enabling technologies, including smart sensing and human-machine communication, have a huge potential for reducing the uncertainties in hazard detection and promoting a more dynamic approach. The main idea is the adoption of a solution based on wearable and fixed sensors used to dynamically monitoring the environments in order to provide, in real time, information about situation context in order to help the workers to better estimate the actual level of risk. The use of IoT poses new problems, including web security, privacy, workers' union acceptance. The implementation of IoT solution requires a special attention to these details, in order to avoid defeats in innovation projects. The paper illustrates the preliminary results developed inside the INAIL Bric project SmartBench related to the use of IoT and RFID beacons to provide information in real time about the equipment, the environment and the worker's physical condition.

1. Introduction

In last decade, the diffusion of novel data transmission technologies has allowed the integration of new devices and items in the cloud of companies and systems. The affirmation of the Internet of Things (IoT) represents the basis of the Industry 4.0 which inherits strengths and weaknesses of each technology involved in the IoT framework.

Nowadays, the application of IoT concept to the industries leads to an improvement of services efficiency, a smart monitoring of the production, and an accurate tracking of the products from the initial phases to the delivery (Atzori 2010).

Concerning the IoT technologies and products applied in the context of industries, Da Xu et al. (2014) present an overview about the most applied communication technologies in Industry 4.0, and the most cited are the radio-frequency identification (RFID) tags, the Bluetooth standard, and the near-field communication (NFC).

The common aspect of these kind of solutions is the transfer of information or power between two or more devices that are not connected by an electrical conductor; indeed, in the context of industries, thanks to its flexibility this feature represents a relevant advantage. Moreover, this kind of products and technologies represent the basis of the Wireless Sensor Networks (WSNs) which mainly use interconnected intelligent sensors to sense and monitor. In this way, the classical cloud system of enterprises and industries is extended by involving smart objects such as machines, shelves, pallets, and each element that belong to the production chain. Kortuem et al. (2010) classify these smart objects by defining three different categories: activity-aware,

policy-aware, and process-aware objects. An activity-aware object can record information about work activities and its own use, the policy-aware object is an activity-aware object that can interpret events and activities with respect to predefined organizational policies, at last, process-aware objects assist workers by providing context-sensitive guidance about tasks and processes.

If on the one hand, as reported in Conway (2016), in recent years the contribution of IoT is increasing especially in the field of Industry 4.0, on the other hand, the cyber security issues related to the introduced technology are nowadays considered a hot topic. A taxonomy of security and privacy issues in IoT context has been analyzed by Alqassem et al. (2014). The authors face the problem of cyber threats, data integrity, and intrusion detection from an IoT point of view. Focusing on the RFID technology, Koho (2011) resumes in his work a detailed list of issues affecting this kind of technology and proposes feasible countermeasures.

Despite the presence of issues related to cyber threats, safety, and security aspects, the widespread diffusion of this kind of technologies in the industrial context is unrestrainable.

Recent research developments, as described in Scheuermann et al. (2015), extend the concept of smart object to the workers by including them in a large environmental network composed by cyber, physical, and human elements; the authors identify this new kind of system as Cyber-Physical Human System (CPHS).

Starting from this kind of system, in this paper we propose a framework based on classical IoT technologies with the aim of proposing a CPHS able to assist workers and inspectors in industries or hazardous environments by analyzing and merging heterogeneous information.

1.1 Paper Outline

The outline of the paper is as follows: In section 2 we collect the guidelines of the SmartBench project by analyzing the user requirements. In Section 3 we describe a framework overview of the system proposed in the SmartBench project with a detailed focus on the environment-human interaction.

The framework functionalities based on RFID technology are resumed in Section 4; finally, some conclusive remarks are collected in Section 5.

2. Project Guidelines and User Requirements

SmartBench is a project funded by INAIL, the Italian Workers' Compensation Authority. It is aiming at the development of a few vertical application for the safety of the workers, as well as of the equipment and of the plants. The focus of SmartBench is, first of all, on the establishments under the Seveso Legislation for the prevention of major chemical accidents. Seveso requires for establishments a higher reliability for equipment, procedures, organization and work ambient. Higher reliability is, anyway, required even in other industries (e.g. power, steel, industrial ports), which are included in the potential user of the project's results.

The vertical applications for equipment safety include:

- a network of sensors for the early detection, by means of acoustic emissions, of defects in primary containment systems (e.g. atmospheric tanks, pressure vessels and pressure piping), so that to avoid the loss of hazardous materials (or energy);
- a system of smart tag for lifting and pressure equipment, for handling all safety relevant information and measurement along the entire lifecycle, so that to optimize inspection and maintenance
- a "software sensor" for merging measurement from physical sensors and information from the smart tag, so that to monitor and prognostic the "health" condition of containment systems and other critical equipment and assure the safe extension of plants' lifetime;

The application of workers' safety includes

- a system, featuring both smart sensors of environmental parameters, and sensors of personal physiological parameters, so that to assist and protects workers operating at industrial units. They may be difficult because the congestion of plants and the structure, the presence of hazardous material, including toxic or flammable gases and fluids, as well as low oxygen areas, smoky and noisy areas, slippery floor and so on.

The ambition of the project is to harmonize the vertical applications, so that to integrate them with the risk assessment and the Safety Management System (SMS), which are the two pillars of the safety at the Seveso establishments, as well as in most chemical process industries. The integrity data may be processed to get the actual failure rates, essential to feed the computation of the likelihood of top events and, consequently, address the SMS. All phases of the SMS cycle may take advantage from the data coming from the smart systems.

2.1 Application for the operating control in the Safety Management System

This paragraph discusses in the detail one phase of the SMS: The operating control. Operating control includes resources, procedures and instruction for inspection and maintenance. They may be continuously updated, exploiting the data about the equipment integrity, gathered by the different innovative sensors on the field, as well as the information collected by the smart tags. The Operating Control in the SMS requires also the operator to assure the safety of contracted workers, during maintenance interventions, even in areas that may become hazardous for unexpected events (e.g. a toxic release). In this case, wearable sensors and ambient sensors provide a large amount of data. They may be merged with information managed in the SMS, so that to monitor and follow up the hazardous situations. There is a huge potential to improve also other SMS phase, including hazard identification, training, management of change, performances monitoring and audit. Further details about SMS related issues are in section 4.

In the next future, the providers of industrial electronics will develop and bring to market many other smart safety systems. Without a tight link with the safety management systems, the smart systems become just technological gadget, with no real effects on safety. These are just examples, but all processes of the SMS may be powered by the data coming from the smart systems and, in turn, most smart safety systems make sense just inside an SMS. In order to assure the dialogue between smart systems and SMS a platform, including protocols and other shared resources are essential. This “safety” logical protocol must be layered over the physical resources, so that to assure the interoperability of different safety systems based on the IoT and the allied technologies.

The applications, developed in previous project funded by INAIL, include an application for save emergency interventions in congested industrial environment (De Cillis & al 2016), an application for safe lifting of containers of hazardous materials (Ancione & al. 2017), an application for the safe access in confined areas (Botti & al 2016) and in machining unit (Gnoni & al., 2016). All these application, should be integrated in the SmartBench platform and eventually work together with the new applications, as well as further applications already available in the market, such as, for instance, the wireless pipe thickness monitoring system, the wireless mobile gas sensors, the wireless vibrations systems.

3. SmartBench Framework Description

The SmartBench framework is based on the cooperation of three fundamental actors: the operator, a mobile application, and environmental smart sensors (ESS) deployed in the surrounding area. It is possible to define the proposed framework as a hybrid wireless network, which involves objects and humans in perfect accord to the IoT paradigm. The operator is equipped with a mobile device and a human smart sensor (HSS) able to collect information about the vital signs and his/her activities in the field. Concerning the HSS it consists of a smart device able to merge row data with the aim to provide aggregate information about the state of the operator. In more details, the HSS is based on a microcontroller, inertial and wearable sensors for a real-time analysis of body chemistry (i.e. CO, CO₂, sweat, humidity, and temperature). The aim to collect this information is demanded to a rugged mobile device which is connected to the HSS via Bluetooth Low Energy (BLE) protocol. Notice that, the proposed solution not require the presence of power-network or pre-deployed communication networks. This is a relevant feature especially in emergency scenarios, often characterized by blackout and, as a consequence, the absence of data connectivity.

The mobile application installed in the tablet is composed by four main modules as depicted in Figure 1:

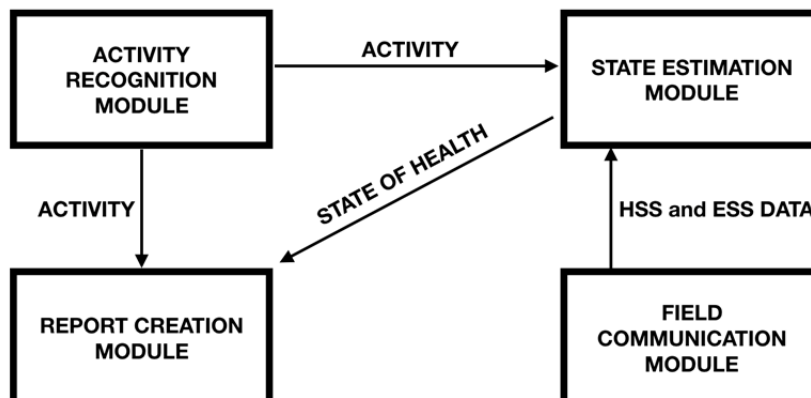

Figure 1: Mobile application logic scheme

- **Activity Recognition Module:** One of the most interesting features of this application is the ability to estimate the actions performed by the operator. A real-time algorithm based on thresholds analyzes the inertial signals and estimates the activity of the operator. In more details, the algorithm is able to recognize the following patterns: running, walking, falling, and lay down. Starting from the activity estimation, if the algorithm recognizes an abnormal behavior (i.e.: a suspected sequence of patterns), it sends a message to the report creation module in order to highlight the anomalous situation (De Cillis & al 2017).
- **State Estimation Module:** The aim of this module is the estimation of the operator state of health and providing warning about dangerous area in the field or low state of health. This module is based on two different analysis: in one hand, the module collects information about the body chemistry and the operator activity, while in the other hand it retrieves information about the field thanks to the presence of multiple ESSs or about other operators in the surrounding area thanks to the other HSSs. The result of this kind of analysis is expressed as a measure of the operator health. The algorithm is able to investigate about the correlations among the multiple information in order to find the presence of cause-effect patterns. The research of correlations is able to discover relations between the operator health state and the presence of hazardous materials or other types of hazards in the field. In addition, thanks to the information exchange among other HSSs, the module is able to recognize if areas far from the operator are considered dangerous.
- **Field Communication Module:** this function is devoted to merging information among HSSs and ESSs. Thanks to the BLE network, the application collects data from HSSs and additional information from the field about the presence of gas, temperature, and humidity. ESSs include awareness logics and adaptive algorithms in order to increase and reduce the sample frequency of data. In this way, the life-time of the battery is preserved.
- **Report Creation Module:** The task to provide a detailed report about the mission of the operator is demanded to this module. Here, thanks to the cooperation with the state estimation and activity recognition modules, a report about the mission is provided. Booth operator and field data are included in the report, moreover its granularity depends on the operator state of health (i.e.: if a low operator health level is computed then the report is more detailed).

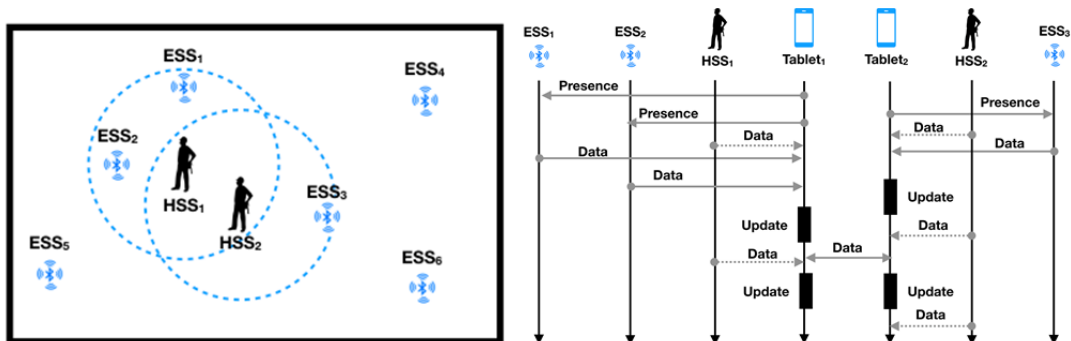

Figure 2 (a) On left: Indoor scenario composed by two operators and five ESSs. Blue dashed circles represent BLE covered area. (b) On right: data exchange among HSSs and ESSs.

For the sake of clarity, in Figure 2(a) a prototypical scenario is shown with the aim to describe the architecture of the proposed framework and the communications among the involved devices. In the proposed environment two operators, equipped with their own HSS and a rugged tablet, are able to retrieve information from the field, in more details the first operator is able to directly retrieve information from ESS₁ and ESS₂. When the mobile application perceives the presence of new ESSs in the surrounding area, it notifies its presence to the environmental smart sensors and starts to read data. More precisely the android tablet manages multiple BLE connections simultaneously, a first connection with the operator's HSS is always active (dashed arrow in Figure 2(b)), while the connections to the ESSs or other HSSs are established when the operator is close enough to the sensors. Once the operator has collected the information from the two ESSs, the mobile application elaborates and analyses the retrieved data in order to estimate the presence of threats. As shown in Figure2(b), due to the reduced distance between the two operators, a new communication channel is dedicated to the information exchange between the mobile applications. In this way both the operators have learned about ESS₁, ESS₂, and ESS₃ by an indirect communication.

With the aim to include also industrial machines in the framework proposed in the SmartBench project also RFID tags are part of the proposed hybrid network. More details about the interaction among the operators and the machines are described in Section 4.

4. Human-Machine Interaction Based on RFID Technology

RFID technologies could be an efficient tool for supporting several processes in SMSs. These technologies are widespread in industrial systems and services for the identification and traceability of products and/or people. The RFID identification, unlike traditional barcode, uses radio waves to read the data encoded on electronic labels (or tags); the reading process performance shall vary from a few centimeters to meters based on the specific RFID device adopted. Some recent applications have showed the potentiality of adopting RFID for supporting SMSs (Sole et al., 2013): Kelm et al (2013) developed an RFID-based application for controlling the correct adoption of Personal Protective Equipment (PPE) at workplace; Chae and Yoshida (2010) proposed the adoption of RFID for preventing collision accidents between workers and equipment; Lee et al. (2011) adopted RFID for reducing risks of interference at construction sites. By analyzing these studies, main field of applications are workers and/or equipment identification and location aiming to reduce risks and prevent injuries.

In the SmartBench project, the technology will be adopted with two main functionalities: *a basic feature* – where RFID is used in a static way - will be the uniquely identification of an equipment; an *advanced feature* will be oriented to activate actions for preventing an incorrect use of a machine or an equipment. The unique identification will enable a quick and reliable data sharing about the whole lifecycle of an equipment: information about occurred unexpected faults as well as planned maintenance activities become available for safety managers and external inspector. The system will support prognostic analyses as data about each intervention carried out on the machinery will be traced and controlled in a more reliable way. A RFID tag will be placed on the machinery; the tag contains the unique identification number of the machinery, thus allowing accessing information stored in a web application. For increasing the security of this process, a Near Field Communication (NFC) tag – which requires a short range of contact to share data - will be adopted. In this way, a dynamic risk analysis shall be developed based on actual condition of the machine. Next, the second feature will enable active actions over the machine/equipment if unsafe conditions will occur. As an example, if the worker – equipped with an RFID tag- does not use the PPE or is not authorized to use that specific equipment – equipped with a RFID reader – the system will stop or does not start the use of machinery. This is a more dynamic feature that will provide real-time alerts to workers aiming to prevent an injury/accident.

5. Conclusions and Future Works

The framework presented in this paper makes it possible to establish a communication network among operators, environmental smart sensors, and industrial machines with the aim to provide a useful tool able to merge data in order to provide a risk assessment analysis. Moreover, one of the advantages of this work is the complete absence of power and/or communication networks installed in the field. To this end the communication protocols and the operative characteristics of the framework are optimized in order to reduce the battery consumption.

Future works will be devoted to the integration of the proposed architecture with the plant network (if available) in order to retrieve other useful data (e.g.: wi-fi camera). Another future enhancement will be focused to the introduction of an indoor positioning system in order to provide to the operators an estimation of their positions in the field.

Acknowledgments

The work was funded by INAIL - Grant PAR/BRIC2016/ID15 "SmartBench Project"

References

- Ancione, G., Kavasidis, I., Merlino, G., Milazzo, M.F. Real-time guidance system for cranes to manage risks due to releases of hazardous materials (2017) Risk, Reliability and Safety: Innovating Theory and Practice - Proceedings of the 26th European Safety and Reliability Conference, ESREL 2016, p. 118-125
- Alqassem, I., & Svetinovic, D. (2014, December). A taxonomy of security and privacy requirements for the Internet of Things (IoT). In Industrial Engineering and Engineering Management (IEEM), 2014 IEEE International Conference on (pp. 1244-1248). IEEE.
- Atzori, L., Iera, A., & Morabito, G. (2010). The internet of things: A survey. Computer networks, 54(15), 2787-2805.

- Botti L., Bragatto P., Duraccio V., Gnoni M.G., Mora C., (2016), Adopting iot technologies to control risks in confined space: a multi-criteria decision tool, *Chemical Engineering Transactions*, 53, 127-132
- Chae, S., & Yoshida, T. (2010). Application of RFID technology to prevention of collision accident with heavy equipment. *Automation in Construction*, 19(3), 368-374.
- Conway, J. (2016). *The Industrial Internet of Things: an evolution to a smart manufacturing enterprise*. Schneider Electric.
- Da Xu, L., He, W., & Li, S. (2014). Internet of things in industries: A survey. *IEEE Transactions on industrial informatics*, 10(4), 2233-2243.
- De Cillis, F., De Simio, F., & Setola, R. (2017). Long-term gait pattern assessment using a tri-axial accelerometer. *Journal of medical engineering & technology*, 41(5), 346-361.
- De Cillis F., Inderst F., Pascucci F., Setola R., Tesei M., Bragatto P., 2016, Improving the safety and the operational efficiency of emergency operators via on-field situational awareness, *Chemical Engineering Transactions*, 53, 331-336
- Gnoni, M. G. Elia, V. Bragatto, P. A. An IOT-based system to prevent injuries in assembly line production systems. *Industrial Engineering and Engineering Management (IEEM)*, 2016 IEEE International Conference Bali 4-7 Dec. 2016, ISSN: 2157-362X DOI 10.1109/IEEM.2016.7798206
- Kelm, A., Laußat, L., Meins-Becker, A., Platz, D., Khazaee, M. J., Costin, A. M., Teizer, J. (2013). Mobile passive Radio Frequency Identification (RFID) portal for automated and rapid control of Personal Protective Equipment (PPE) on construction sites. *Automation in Construction*, 36, 38-52.
- Khoo, B. (2011, October). RFID as an Enabler of the Internet of Things: Issues of Security and Privacy. In *Internet of Things (iThings/CPSCoM)*, 2011 International Conference on and 4th International Conference on Cyber, Physical and Social Computing (pp. 709-712). IEEE.
- Kortuem, G., Kawsar, F., Sundramoorthy, V., & Fitton, D. (2010). Smart objects as building blocks for the internet of things. *IEEE Internet Computing*, 14(1), 44-51.
- Lee, H. S., Lee, K. P., Park, M., Baek, Y., & Lee, S. (2011). RFID-based real-time locating system for construction safety management. *Journal of Computing in Civil Engineering*, 26(3), 366-377.
- Scheuermann, C., Verclas, S., & Bruegge, B. (2015, August). Agile factory-an example of an industry 4.0 manufacturing process. In *Cyber-Physical Systems, Networks, and Applications (CPSNA)*, 2015 IEEE 3rd International Conference on (pp. 43-47). IEEE.
- Sole, M., Musu, C., Boi, F., Giusto, D., & Popescu, V. (2013). RFID sensor network for workplace safety management. In *Emerging Technologies & Factory Automation (ETFA)*, 2013 IEEE 18th Conference on (pp. 1-4). IEEE.