

# Methanol Production from Biomass Gasification: Techno-Economic Assessment of Different Feedstocks

Andre Furtado Amaral<sup>a</sup>, Daniele Previtali<sup>a</sup>, Anna Dell'Angelo<sup>a</sup>, Filippo Bisotti<sup>a</sup>,  
Alessandro Di Pretoro<sup>b</sup>, Ecem M. Andoglu<sup>c</sup>, Simone Colombo<sup>a</sup>, Flavio Manenti<sup>a\*</sup>

<sup>a</sup> Polytechnic University of Milan, CMIC Dept. "Giulio Natta", 32 Piazza Leonardo da Vinci, 20133 Milan, Italy

<sup>b</sup> Université de Toulouse, Laboratoire de Génie Chimique UMR CNRS/INPT/UPS 5503, Toulouse, France

<sup>c</sup> Bilecik Seyh Edebali University, Department of Chemical Engineering, Gulumbe Campus, 11230, Bilecik, Turkey  
[flavio.manenti@polimi.it](mailto:flavio.manenti@polimi.it)

This work presents an updated techno-economic assessment of methanol production, considering an entrained flow gasifier with different second generation biomasses. Computer simulations were performed with the aid of a gasification simulator *GasDS* and with commercial process simulator Aspen HYSYS.

A method was proposed to determine biomass composition in terms of cellulose, hemicellulose and three surrogate compounds that account for the most abundant monomers that compose lignin chains; the lower heat value (LHV) relative error was not bigger than 10%. The kinetic model deriving from this biomass characterization (composition) is not sufficiently accurate to describe biomass gasification; this is due to unrealistically small residence times and the (not modelled) catalytic effect of molten slag. Biomass gasification output is efficiently estimated by using chemical equilibrium. At current methanol market price (350 €/t) the process is economically unfeasible at the current plant capacity of 100 MW LHV biomass input (production costs vary between 360 and 440 €/t).

## 1. Introduction

The current global warming situation, together with matters of international sovereignty, has brought great attention to renewable energy in the last decades. Renewables are locally-produced, low-carbon-impact energy sources which, therefore, are insensitive to international policies or market oscillations. The concept of biorefinery is most adequate to this current energy scenario; in a biorefinery, second generation biomass (residual vegetable biomass usually deriving from agro-industrial activity, such as corn cobs or wheat straw) can be processed to produce commodities that are typical of the traditional oil refinery (Amaral *et al.*, 2016). In the European scenario, biomass is expected to account for more than 50% of renewable energy share (Bentsen and Felby, 2012).

Biomass gasification is a thermal valorization process that is organic with this current energetic scenario, especially in developing countries where input is abundant and cheap. From the process point of view, gasification is a very flexible process: (1) it is capable of processing inputs with differing qualities; (2) the process output, syngas is also extremely flexible in terms of process design. Syngas is a mixture rich in H<sub>2</sub> and CO, but may also contain H<sub>2</sub>O, CO<sub>2</sub>, CH<sub>4</sub>, tars and ashes; almost every organic molecule can be produced from syngas. In this work, biomass gasification is considered, coupled with the perspective of methanol production from syngas. The majority of the world methanol production comes from the steam reforming of natural gas in plants with capacities on the order of 1000 kt of methanol per year (Dahl *et al.*, 2014); the process sizes studied in this work are one order of magnitude below the traditional methanol plants (i.e. around 100 kt of methanol per year) due to the cost and logistics of transporting biomass.

This work proposes an updated techno-economic assessment on methanol production from biomass gasification; the results of such assessment provides insight in the state-of-art while proposing guidelines to close the gap between research and commercial application on the topic. Special concern is given to: (1) the

characterization of the vegetable biomass in terms of its composition; (2) the simulation of the gasification reactor; (3) the process sensitivity to input composition.

## 2. Materials & Methods

The process was studied with computer simulations. Vegetable biomass composition (cellulose, hemicellulose and lignin mass fractions) was determined by performing a data fitting with information from an online database. The gasifier performance and its response to biomass composition is studied in using two different modelling approaches: (1) with the aid of *GasDS*, a specialized gasification simulator; (2) by considering the output streams to be at chemical equilibrium. Commercial process simulator Aspen HYSYS is used to perform mass and energy balances calculations which are then used to perform the economic assessment of the process. Further details on the simulations are presented on the next sections.

### 2.1 Biomass molecular composition

For what concerns the kinetic modeling of pyrolysis and combustion of biomass, among the main components considered are cellulose, hemicellulose and lignin. For this analysis, cellulose and hemicellulose are considered pure components, in opposition to lignin, which is further divided in three subtypes. These lignin subtypes are surrogate compounds that account for the most abundant monomers that compose lignin chains; further details on these compounds are given on the work of (Ranzi *et al.*, 2008).

The atomic composition of any biomass is calculated from an atomic mass balance (AMB). Problem statement: for a given biomass atomic composition ( $\mathbb{C}$ , determined experimentally) and given components atomic composition ( $\mathbb{C}_j$ , from the model), find the biomass components mass fraction ( $\mathbb{k}_j$ ) such that

$$\mathbb{C} = \sum_j \mathbb{C}_j \mathbb{k}_j \quad (1)$$

$$0 \leq \mathbb{k}_j \leq 1 \quad (2)$$

$$\sum_j \mathbb{k}_j = 1 \quad (3)$$

It is instructive first to consider a simpler case in which no constraints are imposed. Any combination of three different molecular components form a linearly independent basis (LIB); since any LIB is able to span  $\mathbb{R}^3$ , this means that at least one solution should be found for every LIB. As a consequence, the AMB with 5 components will have multiple solutions for the no constraint case (and also for some constrained cases).

The problem can be tended by reducing the number of independent variables (from five) to three, by using the experimentally determined composition of cellulose and hemicellulose. For this new AMB, the previously established bounds usually prevent an exact solution to be found, i.e., the atomic experimental composition cannot be matched exactly by a linear combination of the species' composition. It is possible, though, to estimate a solution which is the closest possible to the observed values of the AMB through an optimization process. The criterion chosen for evaluating the goodness of the solution is the minimization of the sum of the squared relative residues (SSRR) of the AMB; this choice avoids high relative errors on the estimation of the hydrogen massive content, which is much lower than oxygen and carbon. For the mathematical details on the solution of the AMB the reader is referred to the following online material (Amaral, 2019).

Biomass parameters were taken from the Phyllis2 database (Energy Research Centre of the Netherlands, 2019) and the calculated lower heating value (LHV) is compared to the value determined experimentally; two entries from the database were used when any single entry could not provide all the required information.

### 2.2 Gasification reactor simulation

An entrained-flow gasifier was considered for our simulations; it is among one of the most diffused gasification technologies. In this configuration the biomass follows concurrently the input gas stream (which in this case is pure oxygen). Biomass input was 100 MW, considering the average between the total input energy (in terms of LHV) and 365 days in the year; oxygen input was 50% of the total biomass input mass flow (considering ashes and 5% moisture).

The gasification reactor was simulated with two different approaches in order to predict output composition and temperature. For the first approach, simulations were performed with the *GasDS* package, a kinetic, phenomenological model; a detailed mechanism is used for the gas-phase reactions while the solid-phase kinetics are based on the biomass composition (in terms of cellulose, hemicellulose and 3 types of lignin) determined with the methods presented on the previous section. For further information on the *GasDS* package the reader is referred to (Cabianca *et al.*, 2016). For the second approach, gasification output is determined by letting the *GasDS* output attain adiabatic chemical equilibrium through minimization of Gibbs

energy, which is calculated using the polynomials provided by (Goos, Burcat and Ruscic, 2018) a.k.a. ‘the NASA polynomials’. The polynomial coefficients are input inside the HYSYS simulator and the ‘Gibbs reactor’ unit is used to perform the calculations.

### 2.3 Techno-economic assessment of methanol production

The methanol production process was simulated with commercial simulator Aspen HYSYS. Figure 1 shows the program flowsheet with the subflowsheets used for each process section; the gasification section is shown in the detail: the GasDS output is read in the ‘GAS\*’ stream, which is let attain adiabatic chemical equilibrium with a ‘Gibbs reactor’-type unit. The steps are summarized in Table 1 according to their order and function.

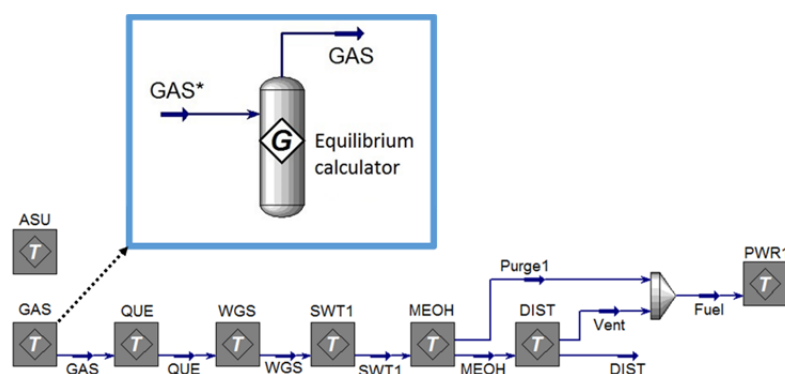

Figure 1: Aspen HYSYS flowsheet showing the biomass conversion process; in detail the gasification section in which adiabatic chemical equilibrium is calculated with a ‘Gibbs reactor’-type unit.

Table 1: Summary of the processing steps according to their order and function.

Operation #	Name	Function
1	ASU – Air separation unit	Produces pure oxygen to be used in the gasifier
2	Gasification	Partially oxidizes biomass to generate producer gas
3	Quenching	Cools gas with a cold gas recycle; residual tar removal
4	Water-gas-shift reaction	Adjusts the H <sub>2</sub> /CO ratio of the syngas stream
5	Sweetening	Removes CO <sub>2</sub> and H <sub>2</sub> S from the syngas
6	MeOH synthesis	Produces MeOH from syngas
7	Distillation	Removes water and dissolved gases from the raw product
8	Power generation	Generation of heat and electricity in a combined cycle

CapEx and OpEx were estimated with the correlations and methods seen in (Turton *et al.*, 2012). Other than methanol, heat and electricity are produced; since methanol is the main component investigated in this work, the results of the economic assessment are presented in terms of methanol production cost. Only 90% of the days of the year were considered work days; this impacts equipment size and, therefore, CapEx. The heat exchanger network (HEN) was estimated as 10% of total CapEx. More details on the simulation and the economic assessment are available on previous works (Amaral *et al.*, 2017).

## 3. Results & Discussion

Table 2 summarizes the results of the previously presented analyses; the table is divided in three sections, each of which related to the correspondent section under Materials & Methods; the explanation and discussion of the results follows the same order.

### 3.1 Biomass molecular composition

The relative deviation for the LHV is seen in the last row of the first section of Table 2; the small values of the relative deviation indicate good agreement between calculated and measured LHV; this finding points in favor of the proposed biomass composition model, even though real biomass composition is significantly more complex. It is interesting to notice that there is no direct connection between the sum of the squared relative residuals (SSRR) and the LHV relative deviation. It is important to realize that the results presented here depend strongly on the methods used to determine cellulose and hemicellulose composition; the most recent

methods determine these quantities directly and produce much more exact values than the older ones, which determine these quantities indirectly (e.g., by sugar analysis, for instance).

*Table 2: Summary of the results; the table is divided in three sections, each of which related to the correspondent section under Materials & Methods. Further explanation of the contents of the table is given on the correspondent subsection under Results & Discussion.*

Name	Corn stover	Wheat straw	Switch grass	Sugarcane bagasse	Almond shells	Olive pits	Birch wood
Phillys2 #	889	977	2436	2342 / 2806	2314	1978 / 2290	2066
Ash (Dry wt%)	7.4	13.5	5.4	1.6	3.3	3.0	0.2
C exp. (DAF wt%)	50.6	53.7	50.6	49.9	50.2	48.3	48.3
H exp. (DAF wt%)	6.32	6.03	5.70	6.04	6.28	6.11	6.02
O exp. (DAF wt%)	43.1	40.3	43.7	44.1	43.6	45.6	45.7
C calc. (DAF wt%)	50.3	50.3	50.4	49.8	49.2	49.4	49.8
H calc. (DAF wt%)	6.20	5.96	5.94	6.01	6.01	5.99	5.85
O calc. (DAF wt%)	43.5	43.7	43.7	44.2	44.8	44.6	44.3
SSRR	5	113	18	0	30	14	27
Cellulose (DAF wt%)	39.7	33.3	40.7	43.1	52.4	29.0	35.8
Hemicellulose (DAF wt%)	27.4	45.2	34.8	35.9	29.9	38.4	25.2
Lignin C (DAF wt%)	2.6	21.5	19.5	17.6	17.7	0.0	0.0
Lignin H (DAF wt%)	30.3	0.0	0.0	3.4	0.0	14.1	6.7
Lignin O (DAF wt%)	0.0	0.0	5.0	0.0	0.0	18.6	32.4
LHV calc. (DAF, MJ/kg)	19.1	18.7	18.7	18.5	18.2	18.4	18.4
$\Delta$ rel LHV (%)	-0.4	1.9	7.6	3.1	0.9	5.7	5.6
O <sub>2</sub> / stoich. O <sub>2</sub> (%)	36	36	36	37	37	37	37
O <sub>2</sub> / Carbon (mol %)	37	37	37	38	38	38	38
Carbon conv. - GasDS (%)	77	80	76	76	79	74	72
Carbon conv. - Equilib. (%)	100	100	100	100	100	100	100
Process cost (M€)	28	29	28	28	28	28	28
MeOH output (LHV GWh)	408	377	404	411	402	414	424
MeOH output (kt)	73	68	72	74	72	74	76
MeOH cost (€/MWh)	68	78	69	67	69	67	65
MeOH cost (€/t)	381	435	387	376	387	375	362

### 3.2 Gasification reactor simulation

The carbon conversion before and after the equilibrium unit (shown in Figure 1) is seen in the last two rows of the second section of Table 2. As the ash content increases the (GasDS) carbon conversion also increases; this is related to the increasing amount of oxygen inserted into the system. (Kunze and Spliethoff, 2011) reported 98% carbon conversion for a similar industrial unit running with coal, which is much less reactive than biomass. Therefore, the equilibrium value is clearly a better estimate of carbon conversion than the values predicted by GasDS. Consistently, the equilibrium value is used throughout the economic analysis, as shown in Figure 1. The smaller conversion values can be attributed to the fact that biomass residence time in the actual gasifier is actually bigger than that in the simulator (which is modelled as a plug flow reactor), plus the catalytic effect of the molten slag on the gasification of char (which is not modelled).

### 3.3 Techno-economic assessment of methanol production

The methanol production cost is seen in the last row of the third section of Table 2. A sensible difference in cost can be seen as the ash content is changed; this correlation is illustrated in Figure 2. This cost difference is due to the differing amounts of oxygen used for biomass with higher amount of ash. In any of the cases, methanol production cost is bigger than the average value from coal gasification found on the review by (IEA-ETSAP and IRENA, 2013): around 350 €/t for scales of up to 100 kt of methanol per year. The same work presents a considerably smaller production cost if the input is natural gas (around 250 €/t, same production range). The current market price of methanol is 350 €/t (Methanex, 2019), which makes the process unfeasible at the current plant capacity of 100 MW LHV biomass input.

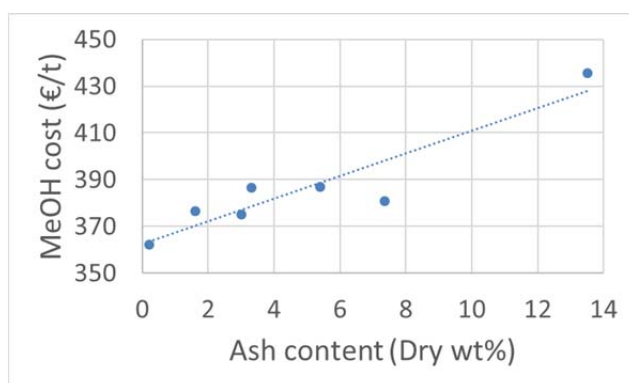

Figure 2: Correlation between ash content and MeOH production cost.

Table 3 presents further details on the economic analysis (considering corn stover as input). The 'HEN' entry (under the CapEx of the process sections) stands for the heat exchanger network, as mentioned previously.

Table 3: Details on the economic analysis (considering corn stover as input).

Process section	CapEx (M€)	OpEx entry	Value (M€)
ASU	15	Amortization	-4
GAS	29	Biomass	-7
QUE	1	Operating labor	-1
WGS	4	Maintenance & repairs	-4
SWT	3	Supplies	-1
MEOH	4	Patents	-1
DIST	1	Taxes and insurance	-2
PWR	5	Overhead	-3
HEN	7	Administration	-1
Total	69	Distribution and selling	-3
		Research and development	-1
		Others	-1
		Produced electricity	1
		Total	-28

The gasifier CapEx was obtained by using a pyrolysis furnace correlation from (Turton *et al.*, 2012); it compares favorably with the gasifier correlation from the work of (Hamelinck and Faaij, 2002), which produces a value of 33 M€ (corrected for inflation and rescaled for the current biomass input). (Hamelinck and Faaij, 2002) present other CapEx correlations which are somewhat more conservative (which estimate, e.g., not 15 but 23 M€ for the ASU), but use economic parameters which result in less conservative OpEx estimates than the evaluation used in this work. As a consequence, the economic assessment used predicts higher methanol production costs.

#### 4. Conclusions

This work presents an updated techno-economic assessment of methanol production. The process is studied through computer simulations by considering an entrained flow gasifier with different second generation biomasses. A method was proposed to determine biomass composition in terms of its main components (cellulose, hemicellulose and lignin); the method gave good agreement between predicted and measured LHV. The kinetic model deriving from this biomass characterization (composition) is not sufficiently accurate to describe biomass gasification; this is due to unrealistically small residence times and the (not modelled) catalytic effect of molten slag. Biomass gasification output is efficiently estimated by using chemical equilibrium. At current methanol market price (350 €/t) the process is economically unfeasible at the current plant capacity of 100 MW LHV biomass input; production costs fluctuate around 370 €/t (for the different biomasses). Two questions remain open for a future work: (1) determination of the most critical points of the process for improvements with a sensitivity analysis; (2) determination of a reasonable value for green incentives with more accurate cost data.

#### Acknowledgments

The authors would like to acknowledge the financial support from the following institutions: National Council of Scientific and Technological Development (CNPq) of Brazil (grant number 205843/2014-0); CARIPLO foundation.

#### References

- Amaral, A. F. (2019) *Supplementary Material*. Available at: <https://tinyurl.com/ICheaP14-SupMat-AFA> (Accessed: 31 January 2019).
- Amaral, A. F., Bozzano, G., Pirola, C., Goryunov, A. G., Chistyakov, A. V. and Manenti, F. (2017) 'Self-sustainable bio-methanol & bio-char coproduction from 2nd generation biomass gasification', *Chemical Engineering Transactions*, 57, pp. 1045–1050. doi: 10.3303/CET1757175.
- Amaral, A. F., Santini, A. S., Bozzano, G., Pirola, C. and Manenti, F. (2016) 'Revamping of the Mantova Chemical District as short-chain lignocellulosic biorefinery', *Chemical Engineering Transactions*, 50, pp. 43–48. doi: 10.3303/CET1650008.
- Bentsen, N. S. and Felby, C. (2012) 'Biomass for energy in the European Union - a review of bioenergy resource assessments.', *Biotechnology for biofuels*, 5(1), p. 25. doi: 10.1186/1754-6834-5-25.
- Cabianca, L., Bassani, A., Amaral, A. F., Rossi, F., Bozzano, G., Ranzi, E., Telen, D., Logist, F., Impe, J. Van and Manenti, F. (2016) 'GASDS: a Kinetic-Based Package for Biomass and Coal Gasification', *Chemical Engineering Transactions*, 50(2004), pp. 247–252. doi: 10.3303/CET1650042.
- Dahl, P. J., Christensen, T., Winter-Madsen, S. and King, S. M. (2014) 'Proven autothermal reforming technology for modern large- scale methanol plants', in *Nitrogen + Syngas 2014 International Conference & Exhibition*. Paris: CRU.
- Energy Research Centre of the Netherlands (2019) *Phyllis2, database for biomass and waste*. Available at: <https://phyllis.nl/> (Accessed: 31 January 2019).
- Goos, E., Burcat, A. and Ruscic, B. (2018) *Extended Third Millenium Ideal Gas Thermochemical Database with updates from Active Thermochemical Tables*. Available at: <http://garfield.chem.elte.hu/Burcat/BURCAT.THR>.
- Hamelinck, C. N. and Faaij, A. P. . (2002) 'Future prospects for production of methanol and hydrogen from biomass', *Journal of Power Sources*, 111(1), pp. 1–22. doi: 10.1016/S0378-7753(02)00220-3.
- IEA-ETSAP and IRENA (2013) *Production of Bio-methanol*. Available at: [www.irena.org/DocumentDownloads/Publications/IRENA-ETSAP Tech Brief I08 Production\\_of\\_Bio-methanol.pdf](http://www.irena.org/DocumentDownloads/Publications/IRENA-ETSAP_Tech_Brief_I08_Production_of_Bio-methanol.pdf) (Accessed: 19 April 2017).
- Kunze, C. and Spliethoff, H. (2011) 'Modelling, comparison and operation experiences of entrained flow gasifier', *Energy Conversion and Management*. Elsevier Ltd, 52(5), pp. 2135–2141. doi: 10.1016/j.enconman.2010.10.049.
- Methanex (2019) *Methanol Price*. Available at: <https://www.methanex.com/our-business/pricing> (Accessed: 31 January 2019).
- Ranzi, E., Cuoci, A., Faravelli, T., Frassoldati, A., Migliavacca, G., Pierucci, S. and Sommariva, S. (2008) 'Chemical Kinetics of Biomass Pyrolysis', *Energy & Fuels*, 22(6), pp. 4292–4300. doi: 10.1021/ef800551t.
- Turton, R., Bailie, R. C., Whiting, W. B., Shaeiwitz, J. A. and Bhattacharyya, D. (2012) *Analysis, Synthesis, and Design of Chemical Processes*. 4th edn. Upper Saddle River, NJ, USA.: Pearson Education, Inc.