

Network of Dividing Wall Columns in Complex Process Units

Roomi Kalita, Amit Kanda, Joseph C. Gentry

GTC Technology US LLC., Houston, USA
 rkalita@gtctech.com

The majority of dividing wall column (DWC) applications in the refining industry consists of stand-alone columns, whether a retrofit or a grassroots column. Functional DWCs, first commercialized in the 1980s, are encountered in naphtha splitters or reformate splitters. Agrawal, 2001 and Asprion et al., 2011 talk about DWC columns for multicomponent separations. Additionally, Yildirim et al., 2011 reviews several DWCs implementations in the industry. In spite of successful stand-alone column implementation, this technology has not been applied on a larger industrial scale to complex refinery units consisting of a network of columns. This paper discusses the application of DWC technology to naphtha hydrotreating (NHT) and isomerization (ISOM) units (Kalita et al., 2018). Most of the columns in these units often operate at high pressures and temperatures that result in a costly and energy-intensive operation. A comparison between conventional NHT/ISOM schemes and DWC integrated NHT/ISOM schemes is presented. The DWC integrated configuration presented is a licensed grassroots unit for a Middle East refinery.

With the demand for such units ramping up in the refining industry, DWCs can revolutionize these process schemes. The benefits of combining the operation of two (or more) columns in such units to create a network of DWCs include lower capital cost due to the lesser number of equipment required. Additionally, DWCs have been shown to lower energy consumption of units by about 20-30% as compared to conventional columns (Dejanovic et al., 2010 and Kiss, 2009). Hence, integrating DWC technology in conventional NHT and ISOM units has the potential to lower the carbon footprint of these units while improving their efficiency and profitability as well.

1. Introduction

Typically, in a NHT unit (Figure 1), after the reactor section, the stabilizer column removes the non-condensable gases from the feed. The top liquid product goes to a deethanizer column to recover liquefied petroleum gas (LPG). The stabilizer bottoms are fed to a two-column naphtha splitter sequence separating into light naphtha (mostly C₅-C₆ components), mid-cut naphtha (C₇) and heavy naphtha (C₈ and heavier). The light naphtha is processed by the deisopentanizer to separate the i-C₅ rich stream at the top. The n-C₅ and heavier fraction is then fed to the ISOM reactor.

In most process schemes, the stabilizer operates at a high pressure, which necessitates the use of relatively expensive medium pressure (MP) steam. Additionally, due to the use of partial condensation, significant C₃-C₄ losses are observed in the off-gas. This leads to the use of a supplementary deethanizer column to recover LPG from the off-gas in the conventional scheme. The isomerization feed is prepared from stabilizer column bottoms in a series of one or more naphtha splitting columns.

Similarly, an ISOM unit (Figure 1) consists of a multitude of columns including deisopentanizer, stabilizer, depentanizer and deisohexanizer columns. The deisopentanizer column separates high octane i-C₅ components from feed and recycle streams. The low octane components from the deisopentanizer bottoms are sent to an isomerization reactor to produce high octane components along with some lights. The stabilizer removes the lighter hydrocarbons (C₄) in the off-gas. The stabilized isomerate is fed to a depentanizer column to concentrate C_{5s}. The downstream deisohexanizer column then separates a light isomerate (mainly i-C₆) and a heavy isomerate (mainly C₇₊ cut) along with a concentrated n-C₆ cut. The n-C₆ cut is recycled to the ISOM reactor for octane upgrading.

These series of columns present a good opportunity to incorporate DWC technology to improve the efficiency of the whole process. Figure 2 shows the final process scheme with multiple DWCS. The next section focuses on the limitations of the individual columns which are rectified using DWC technology. The columns include the stabilizer and naphtha splitters in NHT, and the depentanizer and deisohexanizer columns in the ISOM unit.

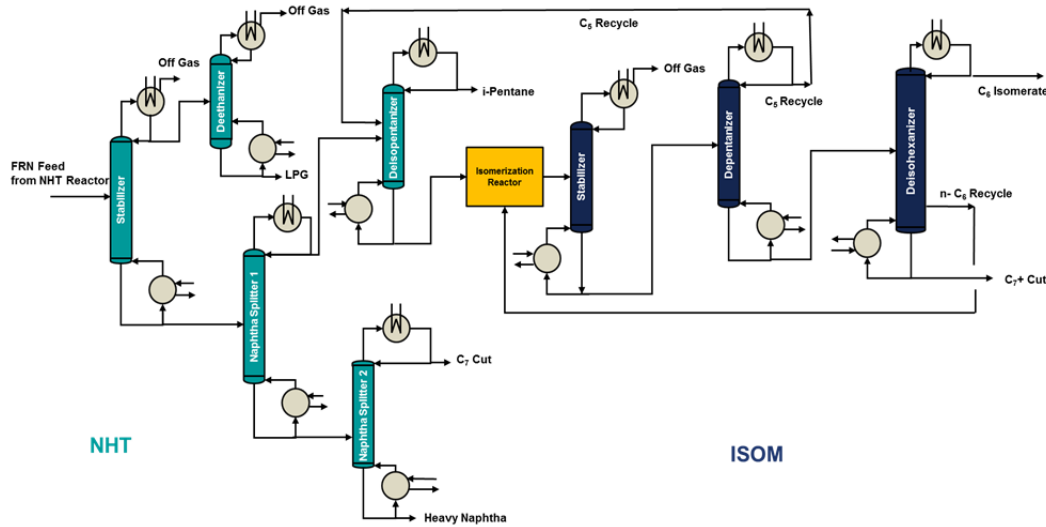

Figure 1: Conventional Naphtha Hydrotreating and Isomerization Process Scheme

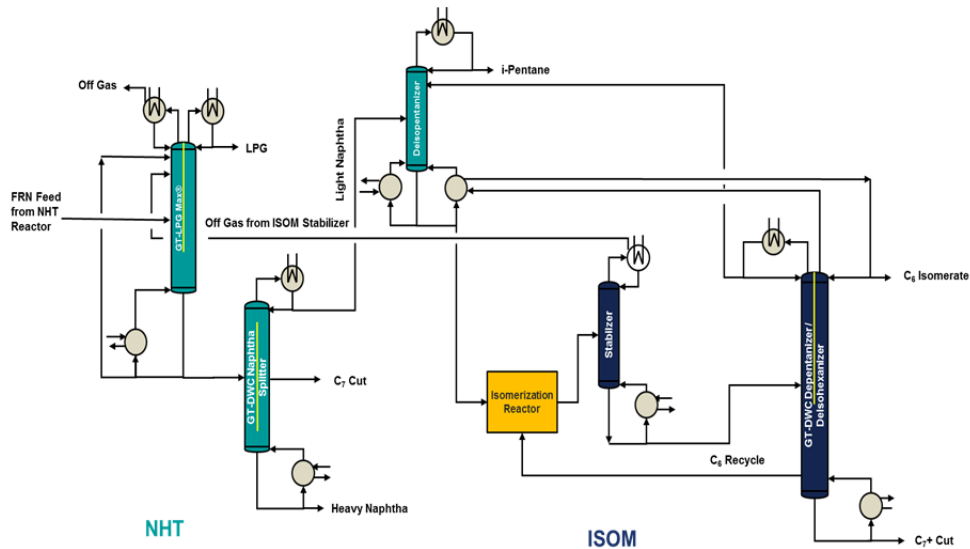

Figure 2: Heat integrated Proprietary DWC Process Scheme for NHT and ISOM units

2. Dividing Wall Columns in Naphtha Hydrotreating (NHT) Units

As shown in Figure 2 and Figure 3, the stabilizer can be replaced with a proprietary top dividing wall column. The wall isolates the top section of the column into separate sections. These operate as independent columns with separate overhead systems. The wall is typically welded to the shell to prevent any intermixing or leakage between the two sides. As a result, separate unit operations – absorption and distillation are performed within the same shell (Bhargava et al., 2015). Use of absorption allows for the column to be operated at a lower pressure than conventional stabilizer columns. In addition, the parallel zones created provides more theoretical stages within the same shell for the required separation.

Commercially, use of absorption to minimize liquid losses in the off-gas is often seen in gas plants with stripper/absorber columns. Applying the same concept in this DWC column, a heavy hydrocarbon stream strips the off-gas of C_3 - C_4 components on the absorption side. These components are pushed down the wall and concentrated as the top product on the distillation side. If the feed contains a suitable amount of C_{5s} (min. 30-40 wt. %), a portion of the C_{5+} bottom product from the DWC column can be used for absorption. The internal recirculation of the heavier components also results in lowering the energy consumption of the stream. When the feed is lean in C_{5s} , an external lean naphtha stream can be used either alongside the bottom C_{5+} stream or independently as the absorption medium. However, this might lead to slight higher reboiling duties as compared to the energy reduction seen with the internal recirculation. Besides the NHT reactor feed, other refinery off-gas streams rich in C_3 - C_4 components can be fed to the DWC column to improve LPG recovery. In this particular case, the ISOM stabilizer off-gas is fed to the DWC column (Figure 2). Consequently, the ISOM stabilizer is operated under a relatively lower pressure and lower temperature heating utility. Similar schemes have been seen proposed in gas plants by Bhargava et al., 2018.

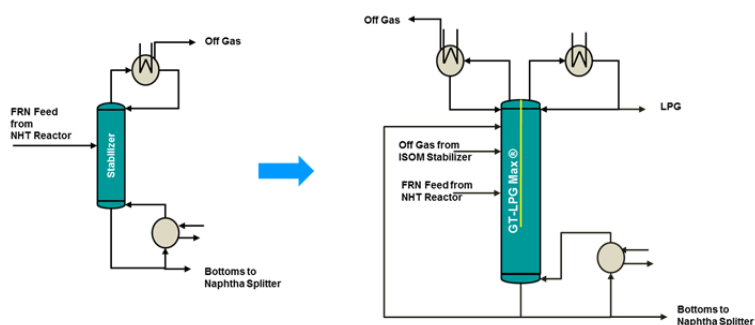

Figure 3: Conventional Stabilizer versus Proprietary DWC Column

Next, the two naphtha splitters in the conventional sequence are replaced by a proprietary DWC naphtha splitter. This is a middle dividing wall column (Figure 5). DWCs work on the principle of removing intrinsic thermodynamic design flaws in conventional distillation columns. One of these flaws arises due to the back-mixing of the feed with the side-cut based on the location of the two streams. The side-cut quality is affected by the contamination of lighter or heavier components. In theory, the back-mixing of components can be avoided by having a pre-fractionator-main-fractionator arrangement as shown in Figure 4a. This system has two reboilers and two condensers for the columns. When the two columns are thermally integrated (Figure 4b), the resulting column is called a Petlyuk Column (Petlyuk et al., 1965). Wolf et al., 1995 discusses the problems affecting the operation of the Petlyuk column for high-purity separation. To circumvent these problem, the Petlyuk column concept has been modified by mechanically integrating the smaller pre-fractionator column in the bigger main column by means of a dividing wall (Figure 4c). Using a DWC has been seen to improve in the separation along with lesser energy consumption (Taylor et al., 2003).

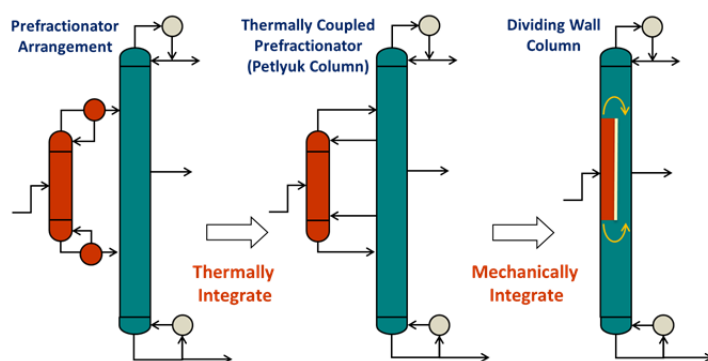

Figure 4a: Pre-fractionator Main fractionator arrangement; 4b: Petlyuk Column, 4c: Dividing Wall Column

Applying this concept to the NHT unit, the two naphtha splitter operations are reduced to a single DWC.

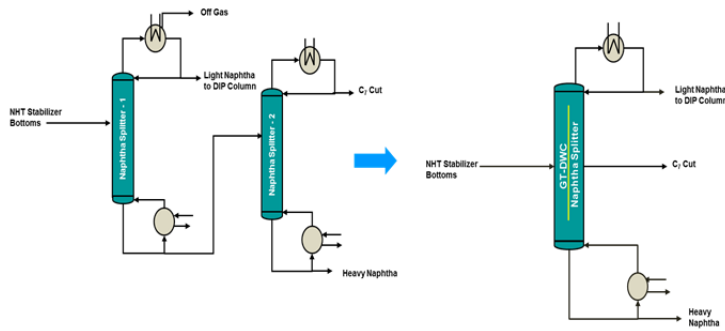

Figure 5: Conventional Naphtha Splitters versus Proprietary DWC Naphtha Splitter

3. Dividing Wall Columns in Isomerization (ISOM) Units

A top dividing wall concept is also used to combine the operation of depentanizer and deisohexanizer columns in the ISOM unit (Figure 6). Unlike the top DWC mentioned in section 2, this column does not use absorption. The pre-fractionation side of the column concentrates the C₅ components. The middle boiling components (C_{6s}) and the heaviest boiling components (C_{7s} and heavier) are pushed down the column to the main fractionation side. Here, C₆ isomerate is separated as the top product. A concentrated n-C₆ stream is removed as side-cut from below the dividing wall section and recycled to the ISOM reactor. C₇₊ cut is obtained as the bottom product of the column.

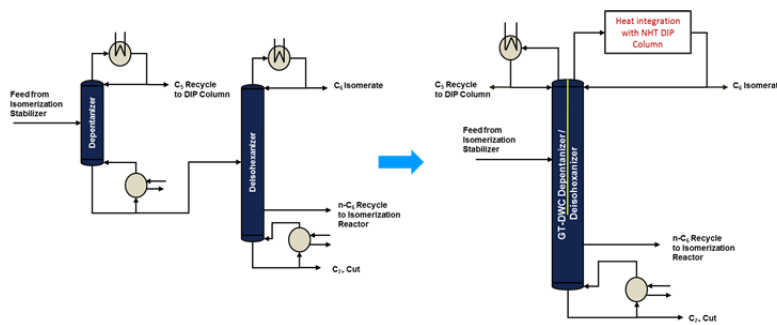

Figure 6: Conventional Depentanizer and Deisohexanizer Columns versus Proprietary DWC column

Additionally, as shown in Figure 6 and Figure 7, a top dividing wall also provides a unique opportunity for heat integration. This is especially beneficial for regions with high utility costs. The proprietary DWC is operated at an elevated pressure. As a result, the hot overhead vapours on the main-fractionation side can be used to provide heating duty to the upstream deisopentanizer column in the NHT unit. The conventional column otherwise operates on LP steam typically.

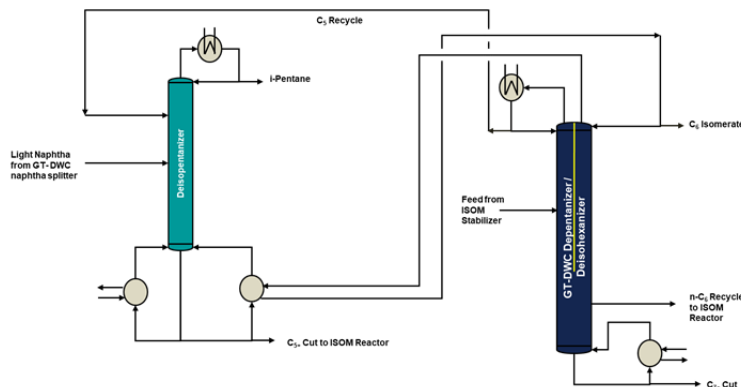

Figure 7: Overhead Heat Integration between NHT Deisopentanizer and Proprietary DWC Column in ISOM

The benefits of a network of DWCs in NHT and ISOM units are summarized in Table 1 and 2. The conventional and DWC-integrated scheme has been modelled using HYSYS and PRO II simulations. The capital cost has been calculated on a US Gulf cost basis, while the energy savings are based on the amount of duty (MW) saved by using a DWC in place of conventional columns.

Table 1: Equipment Count, CAPEX and OPEX Comparison

Parameters	Units	Conventional Design	DWC Design
No. of Columns	-	8	5
Energy Savings	%	-	24 %
Capital Cost	%	Base	70% of Base

Table 2: Heating Utility Comparison

Parameters	Units	Conventional Design	DWC Design with Heat Integration
Feed Rate to NHT Unit	t hr ⁻¹	57	57
Isomerase product	t hr ⁻¹	28.6	28.6
RON of isomerase product	-	92	92
LPG Product Rate	t hr ⁻¹	5.00	7.5
Off Gas Rate	t hr ⁻¹	3.7	1.2
NHT Stabilizer	MW	8.1	8.5
Deethanizer	MW	2.3	N/A
Naphtha Splitter 1& 2	MW	19.3	15.5
Deisopentanizer	MW	14.8	1.1
ISOM Stabilizer	MW	3.5	3.5
Depentanizer	MW	9.3	24.3
Deisohexanizer	MW	12.1	N/A
Total Heating Duty	MW	69.4	52.9



Figure 8: A Top DWC in an ISOM Unit in operation at BPCL Refinery (Mumbai, India).

4. Conclusion

Dividing wall columns, that merge the operation of two or more sequential columns into a single DWC, have slowly emerged as an innovative method of reducing the capital and energy costs in refineries (Taylor et al., 2003). However, most commercial applications, past and present, are confined to stand-alone columns like reformat or naphtha splitters. DWCs have the potential to be applied on a bigger scale in the refinery units of isomerization and naphtha hydrotreating. These units typically consist of a multitude of columns with a high capital and operating cost.

A commercially viable grassroots NHT/ISOM scheme consisting of a network of DWCs is juxtaposed with a conventional scheme to show the advantages. The problems affecting the performance of traditional columns are discussed with an emphasis on how a DWC can rectify these problems. Additionally, specific columns

have been identified within the bigger complex to establish a baseline for similar integration through retrofits of such units.

Overall, integrating DWC technology into a NHT/ISOM process scheme can provide substantial benefits to the refiner in the following areas:

- Fewer number of columns and associated equipment with a smaller plot plan for the whole configuration;
- Improved LPG recovery;
- Reduced energy costs due to low temperature utility used for heating; and
- Better heat integration within the columns.

References

- Agrawal, R., 2001. Multicomponent distillation columns with partitions and multiple reboilers and condensers. *Industrial & engineering chemistry research*, 40(20), pp.4258-4266
- Asprion, N., Kaible, G., 2010, Dividing Wall Columns: Fundamentals and Recent Advances, *Chemical Engineering Processing: Process Intensification*, 49, Issue 2, 139-146
- Bhargava, M., Nelson, C., Gentry, J.C., Siddamshetti, V., 2015, Improved Distillation Efficiency, *Hydrocarbon Processing*, January, 1-4
- Bhargava, M., Kalita, R., Kockler, D., 2018, Dividing Wall Columns for Gas Plants, *PTQ Magazine*, Q2, 75-78
- Dejanovic I., Matijasevic L., Olujic Z., 2010, Dividing Wall Column: A breakthrough towards sustainable distilling, *Chemical Engineering and processing*, 49, 6, 559-580
- Kalita, R., Kanda, A., 2018, Create a Network of Dividing Wall Columns in Complex Process Units, *Hydrocarbon Processing: Process Optimization*, May, pp 85-88
- Kiss, A., 2009, Reactive Dividing-Wall Columns – How to get more with Less Resources, *Chemical Engineering Communications*, 196, pp 1366-1374
- Petlyuk, F, Platonoy, V., Slavinskii, D., 1965, Thermodynamically optimal method for separating multicomponent mixtures, *International Chemical Engineering*, 5 (3), pp 989-996
- Taylor, R., Krishna, R., Kooijman, H., 2003, Real World Modelling of Distillation, *Chemical Engineering Progress*, 99, pp. 28-39
- Wolff E., Skogestad S., 1995, Operation of Integrated Three-Product (Petlyuk) Distillation Columns, *Industrial and Engineering Chemistry Research*, 34, pp. 2094-2103.
- Yildirim, O., Kiss, A., Kenig, E., 2011, Dividing Wall Columns in Chemical Process Industry: A review on current activities, *Separation and Purification Technology*, Elsevier, 80, pp 403-417