

Systematic Methodology for Inherent Safety Indicators Assessment of Early Design Stages of Offshore Oil & Gas Projects

Anna Crivellari*, Alessandro Tugnoli, Valerio Cozzani, Paolo Macini

Dipartimento di Ingegneria Civile, Chimica, Ambientale e dei Materiali, Alma Mater Studiorum - Università di Bologna,
via Terracini 28, 40131 Bologna (Italy)
anna.crivellari2@unibo.com

Offshore oil & gas operations are one of the most hazardous upstream activities since limited space and compact geometry contribute to increase the risk of major accidents. Currently many offshore projects are evolving towards the exploitation of more challenging hydrocarbon fields. The use of the inherent safety philosophy in early stages of the offshore installation design can save lifetime costs and pursue high safety standards. Moreover, an index-based design approach is a comprehensive way to communicate the hazard level of a process route. In this study, a method based on Key Performance Indicators (KPIs) was introduced to assess the inherent safety performance of alternative offshore designs through the modelling of credible accidents consequences for different targets. The main goal is to provide an efficient support tool for safety-oriented choices during the preliminary design steps. A case study regarding an offshore platform processing associated gas with hydrogen sulphide was presented.

1. Introduction

Safety in the offshore oil & gas industry is a high priority considering the increased trend towards sophisticated technologies and more challenging exploration fields. Based on the relevant past experience, risk of major accidents at offshore installations are more complex than that at onshore plants (Christou and Konstantinidou, 2012). Pressurized hydrocarbons processing, space constraints, high congestion are some of crucial issues influencing the safety profile of offshore oil & gas facilities with respect to humans, assets and environment.

The inherent safety concept was recognized as a widespread technique in process risk management strategies with several index-based approaches evaluating the inherent safety level of process plants (Jafari et al., 2018). Previous works demonstrated also the versatility of the inherent safety principles for achieving improved risk reduction at any stage of offshore design and process (Khan and Amyotte, 2002), but suitable indexing metrics have not yet been extensively developed to orient inherently safer choices in this context (Tugnoli et al., 2010). Multi-target Key Performance Indicators (KPIs) were firstly proposed as a systematic consequence-based tool to identify critical safety issues of alternative designs of offshore oil & gas production facilities during the conceptual and basic design phases (Crivellari et al., 2017). By means of such KPIs, the comparison of the inherent safety performance of surface and subsea systems at an offshore gas platform has been recently presented (Tugnoli et al., 2017). Environmental and safety concerns of different designs of an offshore oil installation have been also evaluated (Crivellari et al., 2018). The present study focuses on the application of the KPIs method to competing designs solutions for sour associated gas management in an offshore oil platform.

2. Methodology

The assessment methodology proposed for the calculation of inherent safety KPIs consists of four main steps and requires the offshore design options to be clearly defined. The required input information is primarily process and geometrical data on process and utility equipment, the layout and dimensions of the facility and the meteo-marine conditions of the considered field. Moreover, since the proposed method is a multi-target

approach, the targets of potential hazards are identified among personnel, process equipment containing dangerous materials and marine ecosystems. Conducting a consequence analysis on each respective target will require threshold values of dangerous effects of major accidents to be properly defined (Crivellari et al., 2018). In the first step of the methodology, each selected offshore design is divided into appropriate units and these units are classified according to their functional category (Crivellari et al., 2017). Secondly, a consistent set of three release modes is assigned to each of the categorized equipment: small leak of a 10 mm hole diameter (R1), medium leak of a 50 mm hole diameter (R2), catastrophic rupture including instantaneous release of the entire inventory (R3a) and/or full rupture of the pipe/inlet (R3b). Then, to take into account the unit likelihood to start loss of containment, a specific credit factors ($CF_{i,k}$) is estimated for the i -th release mode of the k -th unit by applying statistical frequency data proposed for offshore oil & gas equipment (IOGP, 2010) to the equipment parts count. During the third step of the procedure, accident scenarios are identified for each release mode by using a set of generic event trees developed in the proposed method for surface and subsea releases from typical offshore equipment. Some examples for gas and liquid leaks from surface hydrocarbons units are illustrated in Figure 1.

R1/R2/R3b	Gas jet	Gas jet ignited	Jet Fire (JF)	Thermal radiation
Gas		Gas dispersion	Toxic Cloud (TC)	Toxic concentration
			Vapour Cloud Explosion (VCE)	Overpressure
			Flash Fire (FF)	Thermal radiation
			Toxic Cloud (TC)	Toxic concentration
R1/R2 /R3b	Pool formation	Pool ignited	Pool Fire (PF)	Thermal radiation
Liquid		Gas dispersion	Toxic Cloud (TC)	Toxic concentration
			Vapour Cloud Explosion (VCE)	Overpressure
			Flash Fire (FF)	Thermal radiation
			Toxic Cloud (TC)	Toxic concentration
			Pool dispersion	Environmental Damage (ED)

Figure 1: Examples of generic event trees proposed for hydrocarbon leaks from offshore equipment

After a proper selection of the final accident scenarios, a damage distance ($d_{i,j,k}$) is calculated for the j -th accident scenario following the i -th release mode of the k -th unit by adopting well-known consequence simulation models and defined threshold values (Crivellari et al., 2018). Finally, a couple of unit KPIs including a potential hazard index and an inherent hazard index is obtained for each identified target. For example, the two KPIs addressing human target, i.e. the human potential hazard index (HPI) and the human inherent hazard index (HHI) are calculated for the k -th unit as follows:

$$HPI_k = \pi \max_i (\max_j d_{i,j,k}^2) \quad (1)$$

$$HHI_k = \pi \sum_i (CF_{i,k} \cdot \max_j d_{i,j,k}^2) \quad (2)$$

The overall HPI and HHI for the analyzed design are calculated by summing those obtained for single units.

3. Case study

3.1 Definition of the process and alternative designs

The method proposed for the inherent safety assessment of offshore oil & gas facilities was applied to an offshore platform with a water depth of 150 m processing crude oil and associated natural gas (mainly methane, CH_4) containing approximately 3 %vol H_2S . After the reservoir fluid is transferred to the platform via a network of pipelines and production manifolds, the incoming mixture is routed to the separation section. Oil, gas and water are separated by gravity in three stages. The oil from the separation train enters the export pumping system to be delivered to the coast via shipping. Associated seawater is treated for further injection into the reservoir. Whereas, the recovered gas from separation stages is recompressed to the pressure of previous separation stage after scrubbing and cooling. The wet gas is dehydrated by physical absorption to avoid possible pipeline corrosion and provided for its transportation to the onshore plant by a sealine with a length of about 100 km. The installation consists of a concrete fixed facility and integrated four-level topside with a large plant view area (45 m x 30 m). Since the goal of the present study is to analyze the inherent safety issues of offshore sour gas processing, two design options were considered which only differ in the associated gas management before its export. As shown in Figure 2, in the design A, the dry gas is first sent to a two-stage compression train, including scrubbers (VN1 and VN2), centrifugal compressors (KA1 and KA2) and coolers (HA1 and HA2). Next, a unit (ML1) comprising a manifold and a launching trap collects the compressed gas to the riser and sealine system (SL1), thus the gas desulphurization is expected to occur at the onshore terminal.

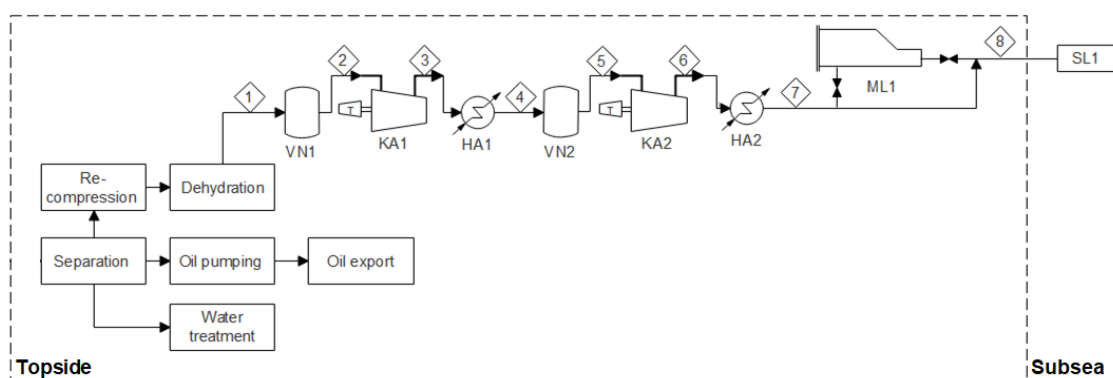

Figure 2: Simplified process flow diagram of design A

On the other hand, design B considers the H_2S removal at the offshore facility, after that the desulfurized gas is compressed and transported ashore. Among the possible sweetening processes of sour associated gas (Hauwert, 2014), the CrystaSulf process developed by Gas Research Institute in the 1990s for high-pressure streams and applied to the Norse gas terminal in 2006, seems to represent the most suitable technology for a mid-range offshore process handling sulphur amounts between 0.2 to 25 t/d (about 3 t/d sulphur in the considered case study). Figure 3 illustrates the simplified scheme of the proposed design. As described by DeBerry et al. (2003), after the dehydration unit, the sour gas enters the CrystaSulf process through a conditioning step aiming at the addition of sulphur dioxide (SO_2) as oxidizing gas. By means of a heat exchanger (HA3) and a specific catalytic reactor (VR1), a portion of the inlet H_2S is oxidized to SO_2 to produce the optimal $H_2S:SO_2$ mole ratio of 2:1. Then, the obtained gas is fed to an absorber (VE1) where a given non-aqueous heavy hydrocarbon solvent converts H_2S and SO_2 into elemental sulphur. The solution stream coming out from VE1 is routed to a crystallizer (VC1) and a cooling loop composed of a centrifugal pump (PA1) and a cooler (HA4) to cause the formation of crystalline sulphur. The regenerated CrystaSulf solution is recycled back to VE1 by being pumped and heated in dedicated units (PA2 and HA5, respectively). The slurry of crystalline sulphur in the settling zone of VC1 is fed to a filter/washing system that produces sulphur to be stored in TA1 for disposal or sale. On the contrary, the clean gas stream exiting from VE1 is compressed in two stages and then exported through the same equipment described in design A (VN3, KA3, HA6, VN4, KA4, HA7, ML2, SL2).

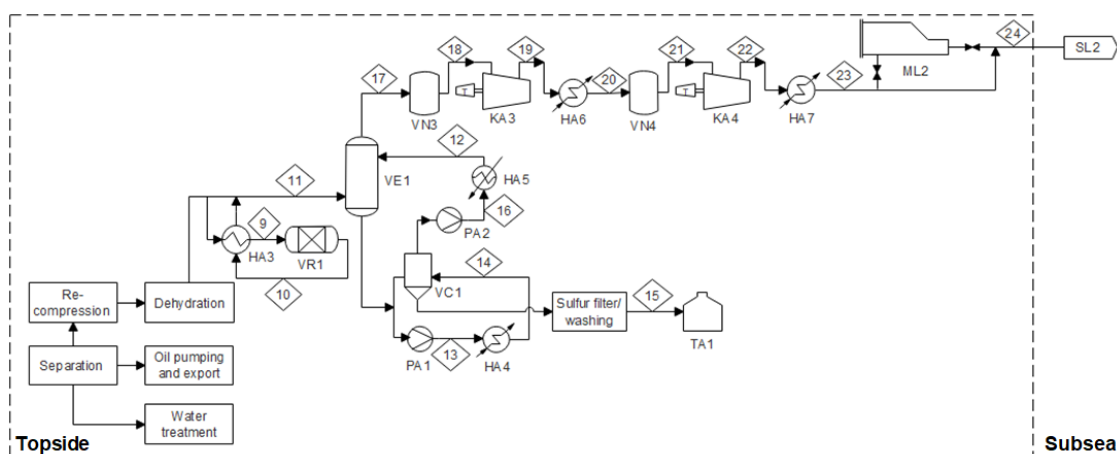

Figure 3: Simplified process flow diagram of design B

The compression system of both designs as well as the CrystaSulf process were considered at the third level of the installation (upper deck), i.e. 33 m above the sea level (a.s.l.), while ML1 and ML2 units between the upper deck and lower deck (21 m a.s.l.). All these zones are confined within solid plated surfaces and highly congested. The data required for the application of the method to the defined designs was estimated through preliminary design of process and equipment. Table 1 summarizes main information of the analyzed units.

Table 1: Main input data of process units considered in the present study

Unit	Reference stream	Key substance	Inlet rate (kg/s)	Pressure (bar); Temperature (°C)
VN1	1	CH ₄ +H ₂ S	75	70; 30
KA1	2	CH ₄ +H ₂ S	75	70; 30
HA1	3	CH ₄ +H ₂ S	75	114; 61
VN2	4	CH ₄ +H ₂ S	75	114; 40
KA2	5	CH ₄ +H ₂ S	75	114; 40
HA2	6	CH ₄ +H ₂ S	75	185; 75
ML1	7	CH ₄ +H ₂ S	75	185; 53
SL1	8	CH ₄ +H ₂ S	75	185; 53
VR1	9	CH ₄ +H ₂ S	25	70; 250
HA3	10	CH ₄ +SO ₂	27	70; 360
VE1	11; 12	CH ₄ +H ₂ S+SO ₂ ; Hydrocarbon solvent	77; 1.2	80; 70 70; 70
VC1	14	Hydrocarbon solvent	1.5	70; 43
PA1, HA4	13	Hydrocarbon solvent	1.5	70; 49
PA2, HA5	16	Hydrocarbon solvent	1.3	70; 43
TA1	15	Sulphur	-	1.0; 25
VN3	17	CH ₄	72	70; 70
KA3	18	CH ₄	72	70; 70
HA6	19	CH ₄	72	114; 105
VN4	20	CH ₄	72	114; 70
KA4	21	CH ₄	72	114; 70
HA7	22	CH ₄	72	185; 110
ML2	23	CH ₄	72	185; 53
SL2	24	CH ₄	72	185; 53

For the purpose of accident consequences modelling, the most conservative environmental conditions in the oil field were assumed in the present study, i.e. average wind speed of 2 m/s, Pasquill category E (night time), air temperature of 25°C (80% relative humidity), seawater surface temperature of 17°C. Concerning the potential hazards associated to the presence of H₂S in pressurized gas streams (Goodwin et al., 2015), the current work focused mainly on personnel at the topside or approaching the platform, thus the thresholds for damage to humans were considered for the calculation of the KPIs addressing human target (Crivellari et al., 2017).

3.2 Results and discussion

Following the procedure of the proposed method, the equipment units illustrated in Figure 1 and Figure 2 were first categorized according to their function. The proposed release categories were associated to the units and for each of them credit factors were estimated by applying OGP release data to the equipment preliminary design. As appeared from some examples in Table 2, ML1 demonstrates values of credit factors of one order of magnitude higher than those estimated for SL1 and SL2 due to its more complex parts count, while VC1 appears slightly less prone to cause loss of containment than HA4.

Next, generic event trees such as those illustrated in Figure 1 were used to identify possible accident scenarios from each unit release mode. Clearly enough, these trees were further adapted to account for specific characteristics of the released material, e.g. TC was neglected in case of release of desulphurized gas (CH₄) from compression and export systems in design B, while only PF was considered to affect human target for releases of flammable liquid hydrocarbon solvent. Moreover, TC was the sole accident scenario modelled for sulphur storage TA1 assuming the accidental combustion of sulphur dusts to SO₂.

After the event tree definition, damage distances were calculated by applying consequence models of accident scenarios described in the Yellow Book (Van Den Bosch and Weterings, 2005). It was assumed that H₂S and SO₂ are not likely to affect damage distances of fire scenarios, while their percentage in the gas streams was taken into account for the VCE modelling through the TNO Multi-Energy model. Finally, as reported by the National Institute for Occupational Safety and Health (NIOSH), for toxic threshold, an Immediately Dangerous to Life and Health of 100 ppm was chosen for both H₂S and SO₂ to carry out the consequence analysis of TC. The damage distances obtained for the worst-case accident scenarios of some units are shown in Table 2.

Table 2: Examples of credit factors and damage distances estimated for some units of the considered designs

Unit	Release mode	Credit factors (1/y)	Worst-case accident scenario	Damage distance (m)
ML1	R1	1.2 E-02	VCE	150
	R2	2.5 E-03	TC	1205
	R3b	1.1 E-03	TC	1905
SL1	R1	1.6 E-03	VCE	150
	R2	3.6 E-04	TC	1531
	R3b	1.7 E-04	TC	3000
SL2	R1	1.6 E-03	VCE	150
	R2	3.6 E-04	JF	287
	R3b	1.7 E-04	FF	417
VC1	R1	1.2 E-02	PF	308
	R2	1.4 E-03	PF	308
	R3a/b	3.7 E-04	PF	308
HA4	R1	1.4 E-02	PF	309
	R2	1.9 E-03	PF	309
	R3a/b	9.0 E-04	PF	309

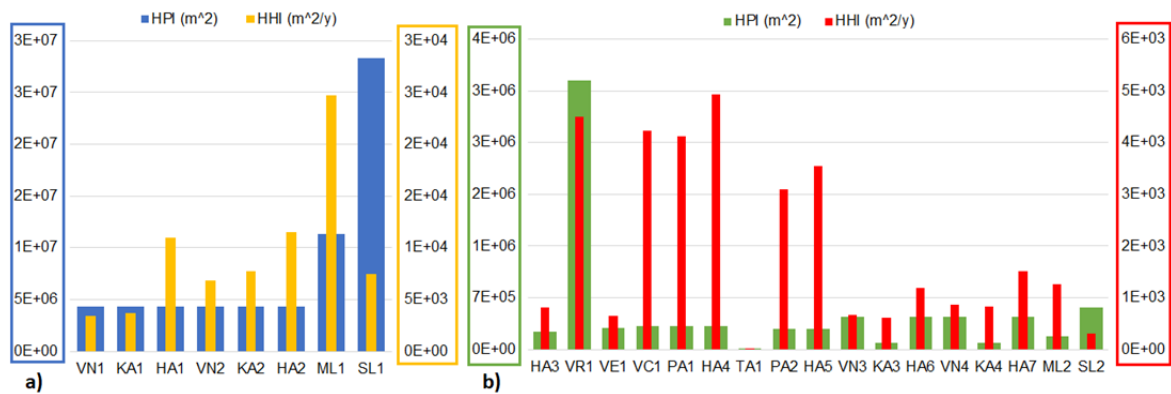

Figure 4: Unit HPI and HHI for (a) design A and (b) design B

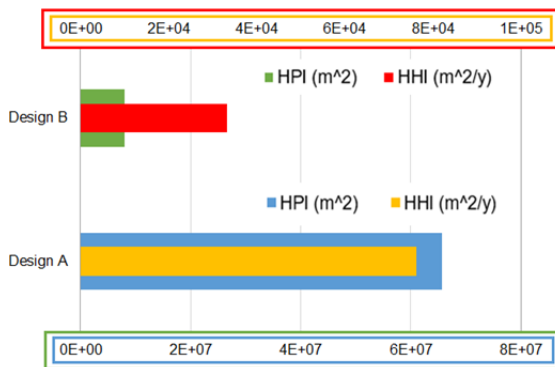

Figure 5: Overall HPI and HHI for the two designs considered in the analysis

The analysis of Table 2 points out that high damage distances for pressurized equipment involving sour gas (ML1, SL1) are reasonably associated to TC, while JF and FF appeared the most severe scenarios in case of release of non-toxic yet highly flammable CH₄ (SL2). These distances lead directly to the calculation of unit HPI according to Eq(1), while unit HHI are obtained by combining the damages distances with related credit factors through Eq(2). Figure 4a and Figure 4b show the results obtained for all the units of the two alternative designs. The illustrations of unit HPI evidence that SL1 is the most hazardous unit of design A (the highest HPI) due to catastrophic TC (Table 2). This is mainly associated to high operating conditions and thus large full-bore release flowrate of this unit compared to others (Table 1). The toxicity of gas released also caused VR1 to be the most potential critical unit of design B, even though the calculated HPI is one order of

magnitude lower than SL1. Conversely, with respect to unit HHI, ML1 became the system with the worst inherent safety performance of design A (the highest HHI) because of the assigned credit factors, as discussed above. Focusing on design B, although units involving liquid solvent (e.g. HA4, VC1, PA1) have “per se” relatively small damage distances, they appeared more likely to start critical events (Table 2) and consequently showed high HHI besides VR1. Finally, the overall HPI and HHI of the two designs are illustrated in Figure 5. As clearly appeared, design B was identified as an inherently safer solution than design A based on potential and inherent KPIs. Therefore, the onsite CrystaSulf process may contribute to decrease the hazard level for offshore personnel as a concrete application of the “substitution” inherent safety keyword, despite the additional equipment in the design.

4. Conclusions

A new approach to the assessment of the inherent safety performance of offshore oil & gas projects was developed as a support tool for decision-making in early design activities. The method is based on the evaluation of a set of multi-target KPIs taking into account special characteristics of offshore facilities. The KPIs calculation is performed by combining the severity of offshore accident scenarios with specific safety scores of oil & gas equipment. In the present contribution, the methodology was applied to the comparison of two designs defined for sour associated gas management at an offshore oil facility. The results demonstrated that the design including emerging H₂S removal technology rather than avoiding onsite gas desulphurization shows the best inherent safety performance according to both potential and credible scenarios affecting human target.

Acknowledgments

The authors gratefully acknowledge the financial support of the Italian Ministry of Economic Development DGS-UNMIG under the project “Indicator for Offshore Safety”.

References

- Christou M. and Konstantinidou M., 2012, Safety of Offshore Oil and Gas Operations: Lessons from Past Accident Analysis, Technical Report No. JRC77767, Joint Research Centre, Luxembourg.
- Crivellari A., Tugnoli A., Macini P., Cozzani V., 2017, Multi-Criteria Indicators for the Inherent Safety Profile of Off-Shore Oil & Gas Facilities, Proceedings of the 13th Offshore Mediterranean Conference and Exhibition, OMC 2017-801, Ravenna, Italy, March, 29-31.
- Crivellari A., Tugnoli A., Martina C., Bonvicini S., Cozzani V., 2018, Inherently Safer Choices in Early Design of Offshore Oil & Gas Installations: A Multi-Target Approach, Proceedings of the 37th International Conference on Ocean, Offshore and Arctic Engineering, OMAE2018-77700, Madrid, Spain, June, 18-22.
- DeBerry D.W., Dalrymple D., Fisher K.S., 2003, Process for Removing Hydrogen Sulfide From Gas Streams Which Include or Are Supplemented With Sulfur Dioxide, By Scrubbing with a Nonaqueous Sorbent, Pub. No. US 2003/0021744 A1.
- Goodwin M.J., Musa O.M., Steed J.W., 2015, Problems Associated with Sour Gas in the Oil Field Industry and Their Solutions, Energy Fuels, 29, 4667-4682.
- Hauwert P., 2014, Sweetening and Sulfur Recovery of Sour Associated Gas and Lean Acid Gas in the Middle East, Proceedings of the International Petroleum Conference, SPE-172058, Abu Dhabi, November, 10-13.
- IOGP, 2010, Process Release Frequencies, Technical Report No. 434-01, International Association of Oil & Gas Producers, London, UK.
- Khan F.I. and Amyotte P.R., 2002, Inherent Safety in Offshore Oil and Gas Activities: A Review of the Present Status and Future Directions, Journal of Loss Prevention in the Process Industries, 15, 4, 279–289.
- Jafari M.J., Mohammadi H., Reniers G, Pouyakian M., Nourai F., Torabi S.A., Miandashti M.R., 2018, Exploring Inherent Process Safety Indicators and Approaches for Their Estimation: A Systematic Review, Journal of Loss Prevention in the Process Industries, 52, 66-80.
- Tugnoli A., Crivellari A., Bonvicini S., Cozzani V., 2017, Development of Key Performance Indicators for the Inherent Safety Profile of Off-shore Oil & Gas Installations, Poster 57291 at Process Safety Symposium of the 10th World Congress of Chemical Engineering, Barcelona, Spain, October, 1-5.
- Tugnoli A., Paltrinieri N., Landucci G., Cozzani V., 2010, LNG Regasification Terminals: Comparing the Inherent Safety Performance of Innovative Technologies, Chemical Engineering Transactions, 19, 391-396.
- Van Den Bosch C.J.H. and Weterings R.A.P.M. (Third Ed.), 2005, Methods for the Calculation of Physical Effects due to Releases of Hazardous Materials (Liquids and Gases) (Yellow Book), Committee for the Prevention of Disasters, The Hague, Netherlands.