

Biomethane Production from Agricultural Resources in the Italian Scenario: Techno-Economic Analysis of Water Wash

Giulio Bortoluzzi^{*a,b}, Manuele Gatti^{a,b}, Alberto Sogni^a, Stefano Consonni^{a,b}

^aLaboratorio Energia e Ambiente Piacenza (LEAP), via Nino Bixio 27/c, Piacenza, Italy

^bPolitecnico di Milano, Dipartimento di Energia, Via Lambruschini 4, Milano, Italy
 giulio.bortoluzzi@polimi.it

This paper evaluates the thermodynamic performance and costs of biomethane production plants tailored to the Italian scenario, by comparing the competitiveness of a water wash based biogas upgrading plant against a conventional biogas-to-electricity facility.

The main goals of the article are the following:

1. Report an updated picture of the state-of-the-art of the Italian biogas plants fleet, taking advantage from a database of existing plants collected by LEAP (Laboratorio Energia e Ambiente Piacenza) in the framework of its techno-economic assessment activity performed over the last years;
2. Review and compare the strengths and drawbacks of the commercially available upgrading processes, both from a technical and economic point of view;
3. Identify and model a case study, based on water wash upgrading, which is suitable for the Italian context, simulating heat and mass balances;
4. Carry out a preliminary economic assessment of the biomethane production chain, i.e. from cradle to pipeline, in order to determine biogas upgrading competitiveness.

A typical agricultural feedstock, made of a mixture of corn silage and cattle manure is considered as reference. Moreover, concerning the plant size, two scenarios are analysed, respectively, (i) featuring the most common biogas production rate of the Italian plants ($500 \text{ Sm}^3_{\text{biogas}}/\text{h}$, which corresponds to roughly $250 \text{ Sm}^3_{\text{biomethane}}/\text{h}$) and (ii) entailing a biogas production rate more suitable for a biomethane plant ($1,000 \text{ Sm}^3_{\text{biogas}}/\text{h}$, roughly $500 \text{ Sm}^3_{\text{biomethane}}/\text{h}$).

1. Introduction

The Italian contribution of primary energy production from anaerobic digestion (1,104 Mtoe out of 10,154 Mtoe of the entire European Union in 2011) allowed Italy to be in the third place after Germany and the United Kingdom (EurObserver'ER, 2012). Thanks to the favourable incentives granted by the Government for electricity production, the number of operating plants rose by about 80 % from 2011 to 2012, reaching the overall value of 1,471, corresponding to a total installed capacity of 1,342 MW_e (Terna, 2013) and allowing biogas to account for about 35 % of the entire bioenergy sector. Anaerobic digestion of organic fraction of waste and wastewater sludge accounts for about 33 % of this power, while the remaining 67 % comes from livestock effluents and agricultural and forestry activities (Terna, 2013). A recent survey, updated to the end of 2012, has detected 994 biogas plants operating in the agricultural sector in Italy, for a total installed power equal to 756 MW_e and an average power of 760 kW_e (Fabbri et al., 2013).

LEAP Laboratory (Laboratorio Energia e Ambiente Piacenza), in the framework of its techno-economic evaluation activity on renewable energy, has analysed about 65 biogas plants, for a total installed capacity of about 33 MW_e, and representing an interesting sample of the Italian fleet. According to LEAP studies, the most common sizes of biogas to electricity plants fall in the 800÷1,000 kW_e range (43 plants), the most prevalent one being 999 kW_e. Concerning the plant feedstock, the mixture of cattle manure and corn or triticum silages (sometimes integrated with sugar beet by-products) is the most widely adopted. The collected data show that the biogas plant CAPEX follows the economies of scale, with average values

decreasing from about 9,500 €/kW_e for 0÷200 kW_e plants to about 4,500 €/kW_e for 800÷1,000 kW_e plants OPEX (O&M + Overheads) follow the same trend, going from 6 c€/kWh_e for 0÷200 kW_e plants to about 4.8 c€/kWh_e for 800÷1,000 kW_e plants. The spread of the 999 kW_e size is mainly due to the economic incentives granted before the 31st December 2012, while the necessity to integrate manure with silage biomass, for larger facilities (e.g. 999 kW_e), is a consequence of the investigated farms size, which turn out to be a limit even in the Italian northern regions with high zoo-technical consistency.

Differently from classical biogas-to-electricity plants, biomethane production facilities rely on the purification/upgrading of such biogas, namely the removal of CO₂ and other contaminants like H₂S, to make available a natural gas-like energy carrier. Such a product, provided that it copes with quality specifications applied to conventional natural gas streams, can then be injected into the grid or sent to a stand-alone compressed distribution system. A recent decree (MSE-Italy, 2013) was released by the Italian Government to promote this biogas exploitation route, making Italy the ninth European country allowing biomethane injection in the public gas grid (DENA, 2013).

Since biomethane production represents a brand-new scenario in the Italian context, it is interesting to evaluate and compare the viability of this biogas-to-biomethane option against the well-established biogas-to-electricity route - all fed with a mixture of cattle slurry, cattle manure and corn silage - while taking into account the recently defined subsidies.

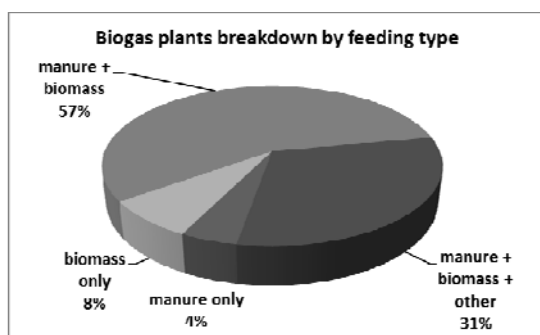

Figure 1: Biogas plants breakdown by feeding type (data collected by LEAP)

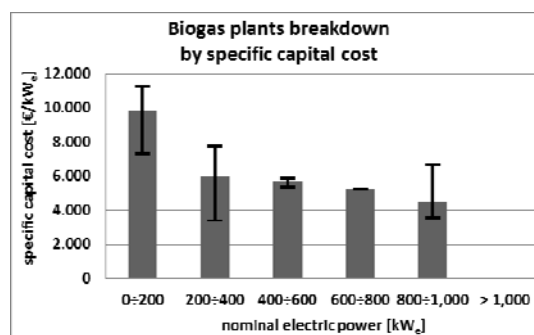

Figure 2: Biogas plants breakdown by specific capital cost (data collected by LEAP)

2. Review of biogas upgrading techniques

Raw biogas from co-digestion of manure and agricultural residues usually contains, on a molar basis, 50÷60 % of CH₄, 40÷50 % of CO₂, water saturated, ≤ 2 % of N₂, ≤ 1 % of O₂, 30÷6,000 ppm of H₂S, less than 100 mg/Nm³ of NH₃, less than 2 mg/Nm³ of aromatic HCs and traces of other contaminants. Since common natural gas quality standards for a high calorific value type grid (H) require a methane (including also other light HC) content larger than 95 %_{MOL}, the major challenge of the purification process lies in the abatement of the CO₂ content. Such a target can be met by properly adopting one of the following commercially proven upgrading technologies, listed in order of maturity: Water Wash (WW), Pressure Swing Adsorption (PSA), amine-based chemical absorption (CHEM), organic solvent-based physical absorption (PHYS), membrane separation (MEM) and cryogenic separation (CRYO): their major characteristics are listed in Table 1.

WW, CHEM and PHYS are all based on the dissolution of CO₂, and possibly other acidic species to be removed from the biogas stream (like H₂S), within a liquid solvent by means of mass transfer favoured by liquid and gas contact into a packed column. In WW and PHYS processes, the absorption is physical, since the selective CO₂ transfer from the gas to the liquid phase and the equilibrium is driven by its solubility and by the partial pressure. Concerning WW, the solubility of CO₂ in water at 25 °C and 1 bar is 0.76 Nm³_{gas}/m³_{liquid}, approximately 26 times the one of CH₄.

On the other hand, in a CHEM process an aqueous solution of alkanolamine chemically reacts with CO₂. Compared to WW and PHYS where the solvent-solute interactions are weaker and solvent regeneration can be easily performed either via flashing/stripping (WW) or by using a limited amount of very low grade heat (PHYS), CO₂ is desorbed from amines by supplying the binding energy required to break the chemical bonds formed during absorption (e.g. 1.6÷1.9 MJ/kg_{CO2} at 140÷160 °C for MonoEthanolAmine). A much more detailed comparison of biogas upgrading techniques is carried out by (Gamba and Pellegrini, 2013) and (Niesner et al., 2013).

According to the most recent statistics (DENA and IEA, 2013) there are 284 biogas upgrading facilities operating worldwide, of which 90 % are located in Europe, with Germany leading the way with around 42

% of the installations. The technologies distribution is the following: WW is the most widespread with 109 sites, followed by PSA, CHEM and MEM.

In terms of size, referring to the German fleet only, WW is generally preferred for large capacities (753 $\text{Nm}^3_{\text{biomethane}}/\text{h}$) and MEM are thought to be more suitable for smaller plants (342 $\text{Nm}^3_{\text{biomethane}}/\text{h}$ on average) where the economies of scale affect negatively the solvent-based technologies.

As a result, in the following techno-economic analysis WW is assessed, as it is the benchmark process better representing the state-of-the-art, even though new technologies like CHEM, PHYS and MEM represent the most attractive alternatives in the near future.

Table 1: Summary of the main characteristics of the most popular biogas upgrading technologies. Partly adapted from (Bauer et al., 2013), and (DENA, 2013)

Criteria	Units	Water Wash	Chemical Absorption	Physical Absorption	PSA	Membrane
Availability	%	95÷96 %	96 %	96÷98 %	95 %	95÷98 %
Methane slip	%	1 % (max)	0.10 %	1.50%	2 % (min)	0.5 %-15 %
Operating pressure	bar	6÷12	1÷1.5	4÷8	3÷10	5÷8 more likely (up to 15 bar)
Electricity consumption	$\text{kWh}/\text{Nm}^3_{\text{raw biogas}}$	0.2÷0.3	0.12	0.2	0.25÷0.3	0.2÷0.3
Heat consumption	$\text{kWh}/\text{Nm}^3_{\text{raw biogas}}$	-	0.55 @ 120÷150 °C	<0.2 @ 55÷80 °C	-	-
CAPEX	$\text{€}/\text{Nm}^3_{\text{raw biogas}}/\text{h}$	1,500@1,000 $\text{Nm}^3_{\text{raw biogas}}/\text{h}$	2,500@1,000 $\text{Nm}^3_{\text{raw biogas}}/\text{h}$	2,000@1,000 $\text{Nm}^3_{\text{raw biogas}}/\text{h}$	2,000@1000 $\text{Nm}^3_{\text{raw biogas}}/\text{h}$	2,000@1,000 $\text{Nm}^3_{\text{raw biogas}}/\text{h}$
		1,000@2,000 $\text{Nm}^3_{\text{raw biogas}}/\text{h}$	2,000@2,000 $\text{Nm}^3_{\text{raw biogas}}/\text{h}$	1,500@2,000 $\text{Nm}^3_{\text{raw biogas}}/\text{h}$	1,500@2,000 $\text{Nm}^3_{\text{raw biogas}}/\text{h}$	2,000@2,000 $\text{Nm}^3_{\text{raw biogas}}/\text{h}$
		$\text{Nm}^3_{\text{raw biogas}}/\text{h}$	$\text{Nm}^3_{\text{raw biogas}}/\text{h}$	$\text{Nm}^3_{\text{raw biogas}}/\text{h}$	$\text{Nm}^3_{\text{raw biogas}}/\text{h}$	$\text{Nm}^3_{\text{raw biogas}}/\text{h}$
Plant diffusion (Worldwide)	#	109	55	18	62	27
Average plant size (Germany)	$\text{Nm}^3_{\text{biomethane}}/\text{h}$	753	531	494	511	342

3. Case study definition

According to the recent decree (MSE-Italy, 2013), and focusing on grid injection configuration, the Italian incentives framework for new agricultural-based biomethane plants is the following: (i) up to 500 Sm^3/h biomethane can be sold directly to GSE (Gestore Servizi Energetici), at an all-inclusive price equal to $2 \cdot \text{PB-GAS}_{\text{AVG } 2012}$, where $\text{PB-GAS}_{\text{AVG } 2012}$ is the average 2012 price of natural gas traded on the balancing market, equal to 28.5 $\text{€}/\text{MWh}_{\text{HHV}}$; (ii) biomethane may be traded directly on the natural gas market, additionally receiving a subsidy equal to $2 \cdot \text{PB-GAS}_{\text{AVG } 2012} - \text{PB-GAS}_{\text{MONTH}}$, where $\text{PB-GAS}_{\text{MONTH}}$ is the average monthly price on the balancing market (e.g. in 2013 $\text{PB-GAS}_{\text{MONTH}} = 25.7 \div 29.4 \text{ €}/\text{MWh}_{\text{HHV}}$). Subsidy (ii) is assigned only to plants either producing less than 250 Sm^3/h biomethane or using at least 50 % by weight of residues or waste as a substrate. All of the incentives are valid for 20 y since the plant start-up, are increased by 50% if the feedstock is 100% made from residues or waste and are submitted to the following variations according to the size: +10% if biomethane capacity $\leq 500 \text{ Sm}^3/\text{h}$; -10 % if biomethane capacity $\geq 1,000 \text{ Sm}^3/\text{h}$.

As from LEAP analysis the reference agricultural biogas plant exports 999 kW_e , roughly corresponding to 500 $\text{Sm}^3_{\text{biogas}}/\text{h}$ or 250 $\text{Sm}^3_{\text{biomethane}}/\text{h}$, and that the incentive scheme adopts 500 $\text{Sm}^3_{\text{biomethane}}/\text{h}$ as size bound of the 10% bonus, in order to catch the scale effects on costing, as a basis of the study these two noteworthy sizes are assumed: 250 $\text{Sm}^3_{\text{biomethane}}/\text{h}$ and 500 $\text{Sm}^3_{\text{biomethane}}/\text{h}$.

4. Process simulation and heat and mass balances

The layout of the water scrubbing process, simulated with Aspen Plus® (AspenTech, v7.3) in order to evaluate its mass and energy balances (based on the assumptions reported in Table 2), closely resembles the one of the most common commercial plants (Malmberg, 2012) and is reported in Figure 3.

In WW the biogas (partly biologically desulphurised in the digesters) is compressed to the absorption pressure of 10 bar in an intercooled two stage reciprocating compressor, the water being removed via condensation, then enters a packed column where CO_2 , H_2S and small amounts of CH_4 are captured in the liquid phase solution. The rich liquid exiting the column (9) is flashed to 3 bar to reduce the CH_4 losses,

generating a vapor CO₂/CH₄ stream (11) recycled to the second compression stage, and a liquid (13) which is sent to a stripper where a counterflowing rising air stream (AIR-2) desorbs CO₂ (and H₂S) from the liquid, at the same time regenerating the solvent (15). The lean water (15), after proper conditioning to reintegrate the evaporated fraction and to avoid contaminant accumulation (blowdown and make-up), is recirculated to the absorber (19). The biomethane stream produced undergoes drying, filtering and odorization and is then throttled to the injection pressure of 5 bar.

The result summary of Table 3 confirms that biomethane quality satisfies the requirements of the current Italian standard for natural gas (MSE-Italy, 2007), CH₄ recovery is 99.6 % and the specific consumption is 0.604 kWh/Nm³_{biomethane}, in line with the values claimed by process suppliers.

Table 2: List of the assumptions adopted for the process simulation

Category	Assumption	Value
Modeling assumptions	Equation Of State	Predictive Soave Redlich Kwong
	Compressors isentropic/driver efficiency	75 % / 95 %
Equipment assumptions	Pump net efficiency	63 %
	Air chiller el. cons. (for biogas cooling)	5 % of heat transferred
	Air flow/Biogas flow rate	6.7 Nm ³ /Nm ³ (real plant Ahrens)
Process design assumptions	Water flow/Biogas flow rate	0.28 m ³ /Nm ³
	Absorption pressure	10 bar
	Flash pressure/Stripper pressure	3 bar / 1.1 bar
	Water temp. at scrubber inlet	20 °C

Table 3: Stream summary and performances related to the 250 Sm³_{biomethane/h} case

Property	ID	BIOGAS	BIOMETH	19-WAT	EXHAUST			
Composition	% _{MOL}	-	-	-	-	W compr	kW	
CO ₂	42.89 %	0.12 %	0.00 %	5.77 %	W pump	kW	62.3	
H ₂ O	5.12 %	0.28 %	100.00 %	2.22 %	W air fan	kW	54.6	
N ₂	0.00 %	0.38 %	0.00 %	72.67 %	W chiller	kW	23.5	
O ₂	0.00 %	0.25 %	0.00 %	19.31 %	W tot	kW	3.7	
CH ₄	52.00 %	98.97 %	0.00 %	0.03 %	Specific cons.	kWh/Nm ³ _{BIOMETHANE}	0.604	
Mass flow rate	kg/s	1.601 · 10 ⁻¹	4.814 · 10 ⁻²	2.736 · 10 ¹	1.245	cons.	kWh/Nm ³ _{BIOGAS}	0.331
Std flow rate	Sm ³ /h	484.3	253.5	-	3,594.0			
Temperature	°C	35	20.24	20.19	20.42			
Pressure	bar	1.1	10	10.5	1.1			
Q _{LHV}	kW	2,373.62	2,364.26	-	9.33			

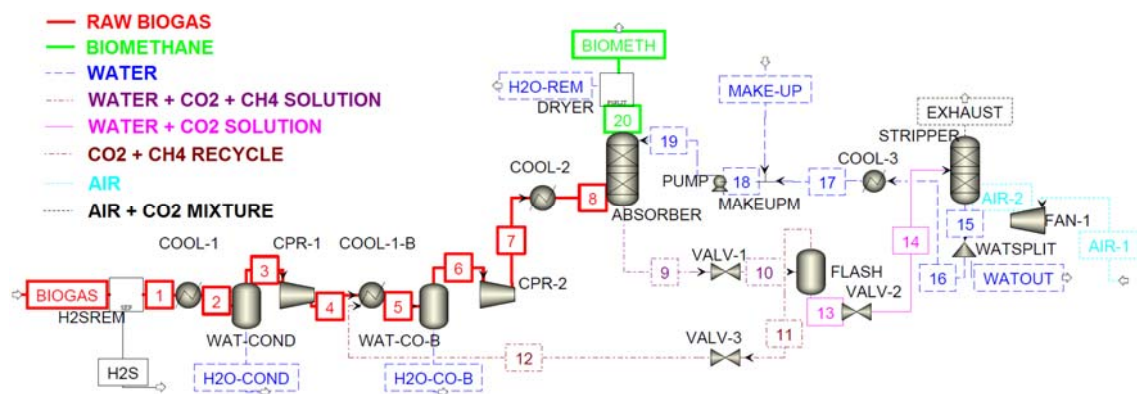

Figure 3: Process Flow Diagram of the biogas upgrading option as implemented in Aspen Plus®

5. Economic assessment

An economic evaluation of the biogas-to-electricity plant (999 kW_e) in comparison with the biogas-to-biomethane ones (250 Sm³_{biomethane}/h and 500 Sm³_{biomethane}/h) is finally set up, in order to compare the profitability of the different solutions. Concerning the 999 kW_e plant, the assumptions on capital (CAPEX) and operative costs (OPEX) and plant availability are taken from LEAP experience (CAPEX 4,500 €/kW_e, OPEX 4.8 c€/kW_e, availability 8,000 h/y), while for the electricity incentive is chosen the value 178 €/MWh_e, which imposes the manure/biomass mixture feeding ratio (70 % manure on mass basis) - namely 29,622 t/y of cattle manure at 2 €/t (transport costs) and 12,000 t/y of corn silage at 35 €/t (cost of own production). A preliminary sizing of the most relevant components of the upgrading plants is performed according to common process engineering practice. The total grass-root cost of each equipment unit (referred to 2013) is evaluated according to the factorial methodology (Ulrich and Vasudevan, 2004), where the purchased equipment cost is multiplied by factors accounting for direct and indirect installation costs, contingencies, escalation and balance of plant. As a result, the upgrading section CAPEX for the 250 Sm³_{biomethane}/h case is 1,184 k€, whereas the one for 500 Sm³_{biomethane}/h is 1,732 k€, both slightly higher than literature (Bauer et al., 2013). For both biomethane options the overall plant CAPEX include also the cost of digesters (3,195 k€ vs. 4,967 k€, taken from LEAP experience), of the heating system satisfying the thermal requirements of digesters by burning a fraction of raw biogas and the upgrading off-gas (37,5 k€ vs. 75 k€, both from LEAP experience), the costs of biomethane conditioning and grid connection (212.5 k€).

Table 5 summarizes the Internal Rate of Return (IRR), the Net Present Value (NPV) and the PayBack Time (PBT) of the three analyzed solutions, while Figure 4 and Figure 5 show the cumulative discounted cash flows of the two biogas-to-biomethane solutions. The economic assessment show that the 999 kW_e biogas-to-electricity options is not profitable, whereas the IRR of both of the biogas-to-biomethane cases is positive. Focusing on the biogas upgrading cases, the 500 Sm³_{biomethane}/h reports a higher profitability (IRR 9.5 %, PBT from 8 to 14 y varying the discount rate), as the economies of scale favorably affect both the investments and the operating costs.

Table 4: Other assumptions adopted for the economic evaluation

Category	Assumption	Biogas-to-Biomethane	
		250 Sm ³ _{biomethane} /h	500 Sm ³ _{biomethane} /h
Operative costs	Feedstocks	manure/silage ratio: 70 % Corn silage: 12,900 t/y @ 35 €/t Cattle manure: 31,700 t/y @ 2 €/t	manure/silage ratio: 70 % Corn silage: 25,790 t/y @ 35 €/t Cattle manure: 63,560 t/y @ 2 €/t
	O&M digesters	4 % of digesters CAPEX	
	O&M upgrading plant	2 % of upgrading CAPEX	
	Digesters electricity consumptions	0.13 kWh _e /Nm ³ _{biogas} @ 0.12 €/kWh _e (industrial users)	
	Upgrading plant electricity consumptions	144.1 kW _e : plant availability @ 0.12 €/kWh _e (industrial users)	246 kW _e : plant availability @ 0.12 €/kWh _e (industrial users)
	Overheads	1% of total plant CAPEX	
Revenues	Biomethane incentive	1.10·2·28.52 €/MWh _{HHV} (average 2012)	1.10·2·28.52 €/MWh _{HHV} (average 2012) - 27.73 (average 2013)
	Biomethane sell price	-	27.75 €/MWh _{HHV} (average 2014)
Other parameters	Plant availability	8,400 h/y	
	Inflation rate	1.9 % (average value of last 5 years)	
	Taxes	1.9 % of Earnings Before Taxes (EBT)	

Table 5: Main results of the economic evaluation on the three plant cases

Parameter	Biogas-to-Electricity	Biogas-to-Biomethane	
	999 kW _e	250 Sm ³ _{biomethane} /h	500 Sm ³ _{biomethane} /h
IRR	-	1.54 %	9.5 %
NPV	about -0.15 M€	about 0.6 M€	about 8.2 M€
PBT	-	14 y (discount rate 0 %)	8 to 14 y (discount rate from 0 % to 7.5 %)

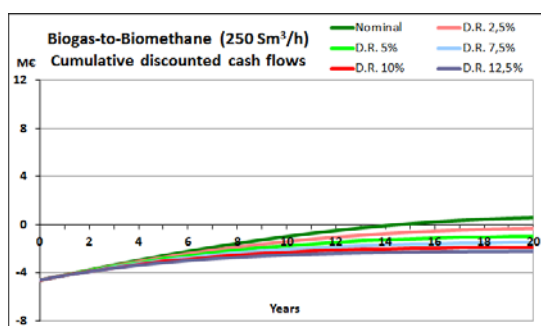

Figure 4: Cumulative discounted cash flows - 1.

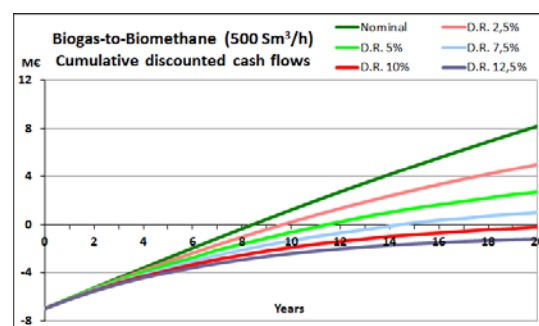

Figure 5: Cumulative discounted cash flows - 2.

6. Conclusions

After a review of the most widespread and promising biogas upgrading technologies, the paper assesses the performances and costs for a water wash plant via process simulation, sizing and costing. The technical evaluation proves that WW technology ensures the standards for biomethane grid injection. The economic analysis shows how the biogas-to-biomethane solution becomes much more attractive for middle size plants (500 Sm³ biomethane/h, IRR 9.5 %) rather than for smaller ones (i.e. 250 Sm³ biomethane/h, IRR 1.54 %). However the subsidies guarantee a positive profitability, though very limited, even for the 250 Sm³ biomethane/h plant size, which could reach the same profitability of the middle size plant (IRR 9.5 %) if the overall plant CAPEX decreases by 40 %. They could become an alternative to the corresponding 999 kW_e biogas plant whose investment, due to the recently decreased economic incentives on electricity from biogas, today is no more profitable.

References

- Bauer F., Hultberg C., Persson T., Tamm D., 2013. Biogas upgrading – Review of commercial technologies. Swedish Gas Technology Centre, Malmö (Sweden).
- EurObserver'ER, 2012. Barometers, Interactive EurObserver'ER Database <www.eurobserv-er.org>, Accessed on 20/12/2013.
- Fabrizi C., Labartino N., Manfredi S., Piccinini S., 2013. Biogas, the sector is structured and continues to grow (ITA), L'Informatore Agrario, Supplemento Energia Rinnovabile, 11, 11-16.
- Gamba S., Pellegrini L., 2013. Biogas Upgrading: Analysis and Comparison Between Water and Chemical Scrubbings. Chemical Engineering Transactions - Vol.32 DOI:10.3303/CET1332213
- German Energy Agency (DENA), 2013. GreenGasGrids project. <www.greengasgrids.eu/market-platform.html>, Accessed 19/01/2014.
- IEA, 2013. IEA Bioenergy Task 37 Plant lists. <www.iea-biogas.net/plant-list.html>, Accessed on 08/12/2013.
- Malmberg E., 2012. Upgrade biogas to biomethane with reliable technology. <www.malmberg.se>, Accessed on 15/12/2013
- Ministry of Economic Development (MSE-Italy), 2007. Approval of the technical regulation on the physical and chemical characteristics and the presence of other components in the fuel gas to be pumped (ITA). 19th February 2007
- Ministry of Economic Development (MSE-Italy), 2012. Incentives for electricity production from renewable energy non-photovoltaic (ITA). 6th July 2012.
- Ministry of Economic Development (MSE-Italy), 2013. Incentives for biomethane injection into the natural gas grid (ITA). 17th December 2013.
- Terna, 2013. Statistical data on electricity in Italy - Year 2012 (ITA), <www.terna.it> Accessed on 05/12/2013
- Niesner J., Jecha D., Stehlik P., 2013. Biogas Upgrading Techniques: State of Art Review in European Region, Chemical Engineering Transactions - Vol.35 DOI: 10.3303/CET1335086
- Ulrich G.D., Vasudevan P.T., 2004. Chemical engineering process design and economics: a practical guide (2nd edition). Process Publishing, Durham, New Hampshire.