

Reformer and membrane modules plant for natural gas conversion to hydrogen: performance assessment

De Falco M.^a, Iaquaniello G.^b, Marrelli L.^a

^a Dept. of Chemical Engineering, Materials and Environment, University of Rome "La Sapienza", via Eudossiana 18, 00184 – Rome – Italy

^b Technip-KTI S.p.a., Rome

It is known that membrane technology may play a crucial role in the innovation and improvement of hydrogen production processes from natural gas and heavy hydrocarbons. Aim of this work is the performance assessment of a Reformer and Membrane Modules (RMM) hydrogen production plant. The plant is a series of modules each composed by a natural gas steam reforming reactor and a Pd-based membrane able to separate at high temperature the hydrogen produced. The major advantage of RMM architecture is the shift of chemical equilibrium favouring hydrogen production due to the removal of hydrogen through membranes at each reaction step, thus improving hydrogen yield while simultaneously allowing methane conversion at temperatures below 650°C. Lower operating temperatures allow location of the modules downstream of a gas turbine, achieving an efficient hybrid system producing electric power and hydrogen with a significant reduction in energy consumption of approximately 10% relative to conventional systems.

Fundamental concepts are analyzed and integrated into a process scheme and effects of operating variables are described.

1. Introduction

Steam reforming of natural gas is a well-established technology for hydrogen production in refining and fertilizer industries. In a typical tubular fixed-bed steam reformer, the process requires high temperatures (850-1000°C) and high pressure (15-40 bar), in order to convert the feed into hydrogen according to the strongly endothermic steam reforming reaction (1) and the moderately exothermic water-gas shift reaction (2):

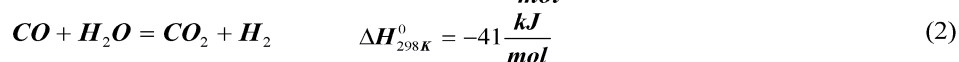
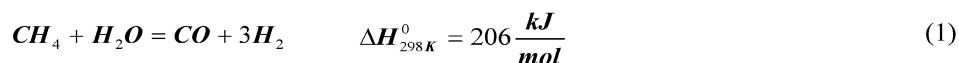

Fixed-bed reformers are placed inside a furnace, where a fraction of natural gas feedstock is burned to supply the reactions heat duty. The hydrogen produced is separated from the outlet gas mixture by means of a Pressure Swing Adsorption (PSA) unit.

In this paper, a novel technology is described. The core of the process scheme is a two steps Reformer and Membrane Module (RMM) coupled to a commercial gas turbine,

with the aim of producing both hydrogen and electric power. Figure 1 shows the RMM concept. The reformer feed is sent to a convective steam reformer where it is partially converted into hydrogen. Hydrogen is recovered through a Pd-alloy membrane separation module, while the retentate is sent to the next step or recycled to the first module.

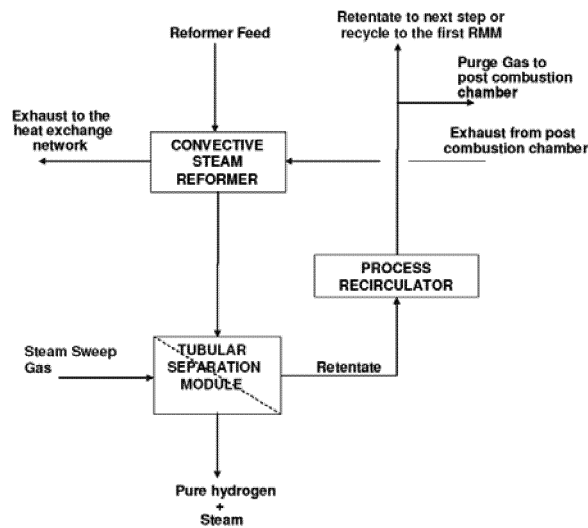

Figure 1 – Single reformer and membrane module layout

The proposed RMM technology is distinct from both the conventional steam reforming process described by Elnashaie and Elshishini (1993) and Dybkjaer (1995) and membrane reactor (MR) technology assessed by Shu (1994) and Gallucci (2004). The latter typically combines the steam reforming reaction with hydrogen separation through selective membrane in one unit and separates hydrogen immediately as it is formed. RMM technology provides the following benefits in respect to integrated membrane reactors:

- it makes it possible to perform hydrogen separation at a temperature near 450°C, slightly lower than the reforming temperature, increasing the stability and life of the membranes;
- the reforming temperature can be optimized independent of the membrane constraints due to the presence of a heat exchanger between the reactor and the separation module;
- it simplifies the mechanical design of membrane tubes relative to those embedded in catalyst tubes;
- it simplifies maintenance of the Pd-Ag membrane modules and catalyst replacement.

Furthermore in this membrane configuration, it is possible to replicate the RMM until the desired natural gas conversion is achieved.

1.1 Process description

Figure 2 shows a two steps RMM hydrogen production plant. Natural gas is the plant feed, which is compressed, heated and mixed with hydrogen recycle before entering the HDS reactor, where sulfur compounds are hydro-desulfurized to form H₂S which is removed by reaction with ZnO. The desulfurized feed is then mixed with steam in a ratio of 2.5 mol H₂O/mol C. The feed gas enters the first reforming step at a temperature near 530°C and exits at 650°C. These operating temperatures have been set in order to simplify the design and metallurgy of the reforming tubes. The reformed gas, before entering the first separation module, is cooled to 450°C, to allow a more stable operation of Pd-based composite membranes. Dense, pin-hole-free Pd-alloy membranes have a very high selectivity towards hydrogen, yielding permeate side stream containing H₂ essentially free of impurities but diluted with the sweep gas (water steam). The permeated mixture is cooled, condensing steam and removing water. The retentate from the first membrane unit then moves to the second reforming step. After the second reaction step and before entering the second hydrogen separation module, CO₂ is removed from the partially reformed stream. This allows a higher hydrogen flux through the second membrane module because of the increased hydrogen partial pressure in the retentate side according to Sieverts' law:

$$J_{H_2} = \frac{B_H}{\delta} \cdot (p_{H_2,r}^{0.5} - p_{H_2,p}^{0.5}) \quad (3)$$

where B_H is the hydrogen permeability, δ is the membrane thickness, $p_{H_2,r}$ and $p_{H_2,p}$ are the hydrogen partial pressures in the retentate (feed) and in the permeate sides, respectively. A fraction of this retentate could be recycled to the feed entering the first reforming step, the other fraction is fed to the gas turbine for electricity production. The permeated hydrogen is partially separated from steam by condensation and routed to a compression section and to a PSA unit where the final purification is carried out. A portion of H₂ produced is recycled to the natural gas feed where it is needed to keep reforming catalyst in a reduced (active) state.

2. Design variables

Simulations have been made by a standard process simulator (PRO II), assuming that chemical equilibrium is established at reforming outlet conditions. The reforming reactors have been simulated as a number of isothermal fixed bed catalyst tubes, with heat supplied to the external surface of the tubes. An overall pressure drop of 0.5 bar has been imposed for each reformer.

The "feedstock+fuel" (FF) efficiency is a key parameter used to evaluate steam reforming plant performance. It represents the amount of heat used (as feed to the process and fuel to the gas turbine) to obtain 1 Nm³/h of hydrogen. In this analysis such a parameter has been modified to account for the cogenerative production of electric energy (considered to be 40% efficient in the conversion of fuel into electric energy):

$$\text{Feedstock + Fuel efficiency} = \frac{\{Feed + Fuel\} - \left\{ \frac{\text{Electrical Power Export}}{0.4} \right\} - \{Export Steam\} \cdot \frac{kcal/h}{Nm^3/h}}{H_2 \text{ production}} \quad (4)$$

The lower the feedstock+fuel efficiency the higher the plant efficiency.

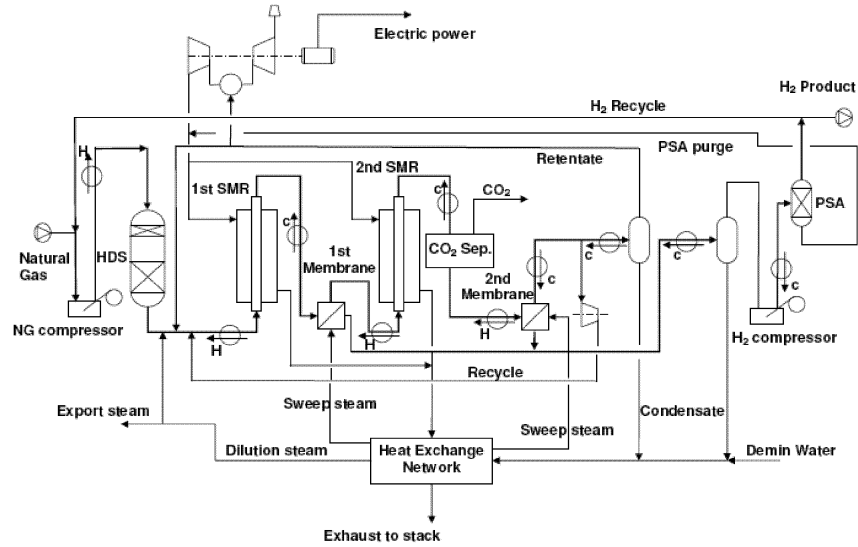

Figure 2 - Two step RMM plant layout

2.1 Plant capacity and Export Steam

Integration of a hydrogen plant with a gas turbine (GT) can improve the overall thermal efficiency of the hybrid configuration. One method of using gas turbine exhausts in a hydrogen production unit is to use it as the preheated combustion gas of the reformer. Both hydrogen plant capacity and gas turbine size influence the overall thermal efficiency. Because the adjustment of hydrogen production capacity is easier than modification of a gas turbine, it is better to select a gas turbine first (24.8 MW Siemens GT10B in this study), and then match the plant capacity analyzing the overall plant efficiency. Optimization of steam management can also impact the efficiency: the more export steam produced, the higher efficiency achieved. It is a common practice in hydrogen plant efficiency evaluation to include the export steam contribution in the FF value. Nonetheless, it should be verified that a real need of export steam exists.

In figure 3, the feedstock + fuel efficiency (FF) versus the plant capacity is shown for three different reforming temperatures. The solid lines represent the FF without considering the export steam contribution, while the dash-dot lines take export steam contribution into consideration. While the FF efficiency without export steam contribution decreases with the increase of the plant capacity, the curve calculated considering the export steam as well exhibits an opposite trend. The two FF curves converge at a point where no export steam is available, as all steam produced is consumed in the process. The methane conversion increases linearly with plant capacity. Highest plant efficiency is achieved when FF value is the lowest. This occurs when the amount of export steam available increases corresponding to the decrease of methane conversion.

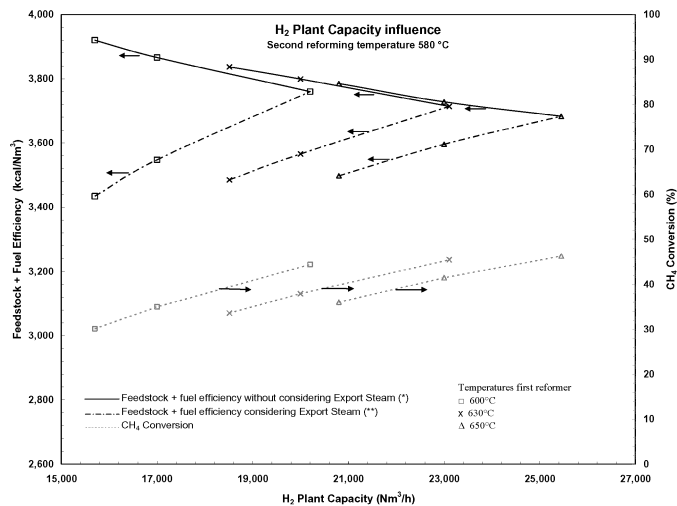

Figure 3 - Feedstock + fuel efficiency versus hydrogen production (2nd reformer temperature = 580°C)

2.2 Reforming temperature

Figure 3 illustrates that, for a specific GT, higher reformer temperature tends to increase the associated H₂ production.

For a fixed GT and a fixed capacity, the operability range of the reforming temperature presents an upper and a lower limit. The upper limits correspond to a too high methane conversion which makes the retentate LHV too low to feed the GT and requires an extra amount of natural gas to the GT. Conversely with the lower limit no natural gas is fed to the GT which runs only on retentate.

In figure 3, the second stage reforming temperature has been fixed at 580°C, while the first was changed from 600°C to 650°C. Figure 4 shows the influence of the second stage reforming temperature on three plant capacities: 17,000, 20,000 and 23,000 Nm³/h of hydrogen production, fixing the first reforming temperature at 630°C.

The FF value, without considering the export steam contribution (solid lines), increases with increasing temperature, whereas an opposite trend is shown when considering the export steam (dash-dot lines). In fact, the higher the temperature the more heat is available for the export steam production.

3. Conclusions

The present work assesses the performance of a hydrogen production plant utilizing Reformer and Membrane Modules (RMM), by which the hydrogen produced in reaction units is separated by Pd-based membranes. A major advantage for RMM architecture is the possibility to shift the chemical equilibrium toward the right-hand side of the reaction thanks to the removal of a reaction product (hydrogen) before each reaction step, improving hydrogen production while at the same time allowing methane conversion at temperatures lower than 650°C. Such a low operating temperature makes it possible to locate the RMM downstream of a gas turbine, achieving an efficient hybrid system (electric power + hydrogen) with a significant reduction in energy

consumption of approximately 10%. The simulations performed allow to conclude that export steam production and higher second reformer temperature lead to an improvement of process efficiency. For a more detailed analysis of the process described, the authors suggest the papers of De Falco (2008) and De Falco (2009).

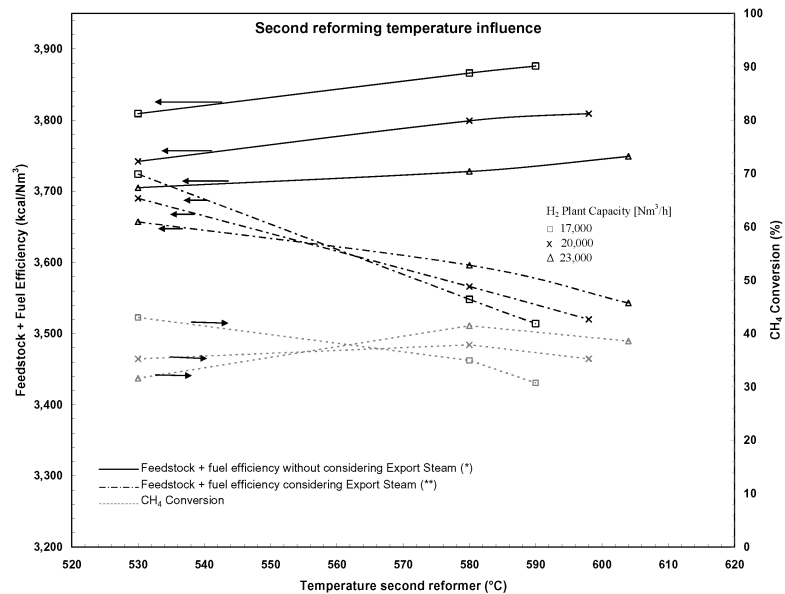

Figure 4 - Feedstock + fuel efficiency versus second stage reforming

References

- De Falco M., Barba D., Cosenza S., Iaquaniello G., Farace A., Giacobbe F.G., 2009, Reformer and membrane modules plant to optimize natural gas conversion to hydrogen, Special Issue of Asia-Pacific Journal of Chemical Engineering on Membrane Reactors, in press.
- De Falco M., Barba D., Cosenza S., Iaquaniello G., Marrelli L., 2008, Reformer and membrane modules plant powered by a nuclear reactor or by a solar heated molten salts: assessment of the design variables and production cost evaluation, In. J. Hy. En. 33, 5326-5334.
- Dybkjaer I., 1993, Tubular reforming and autothermal reforming of natural gas – an overview of available processes, Fuel Processing Technology 42, 85-107.
- Elnashaie S. and Elshishini S., 1993, Modelling, simulation and optimization of industrial fixed bed catalytic reactors, Vol. 7 of Topics in Chemical Engineering, Gordon and Breach Science Publisher.
- Gallucci F., Paturzo L., Basile A., 2004, A simulation study of steam reforming of methane in a dense tubular membrane reactor, Int. J. Hy. En. 29, 611-617.
- Shu J., Grandjean B., Kaliaguine S., 1994, Methane steam reforming in asymmetric Pd and Pd-Ag porous SS membrane reactors, Appl. Catal. A: General 119, 305-325.