

## Interfacial Instability on Bubble Surface

Karlov S.P., Kazenin D.A., Vyazmin A.V.

Moscow State University of Environmental Engineering, Department of Chemical Engineering

Ul. Staraya Basmsnaya, 21/4, 105066, Moscow, Russia; e-mail: av1958@list.ru

Interference laser spectroscopy was used to study the macrokinetics of absorption of carbon dioxide by aqueous solutions of chemisorbents. Chemisorption was shown to be a complex and multistage process. Its evolution included the occurrence of a diffusion-controlled chemical reaction close to the interphase boundary, the appearance of instability, and the development of convection in the liquid phase. The main rules governing stability loss during chemisorption were considered.

### 1. Introduction

Knowledge of the main macrokinetic rules that govern chemisorption is of considerable importance for chemistry, chemical technology, biology, and medicine. Because of its importance for practical applications, chemisorption has been studied in much detail. These studies were therefore based on the classic concept of the diffusion-kinetic mechanism of chemical reactions with mass transfer (Frank-Kamenetskii, 1987).

The macrokinetics of chemisorption is much more complex in reality, in the first place because of the presence and mutual influence of numerous physicochemical factors that determine the sequence of elementary events. These are chemical, diffusion, and hydrodynamic interactions that reflect the main laws of conservation that are in force in nature. It follows that, no matter what the nature substances, all chemisorption processes should be governed by certain general fundamental rules.

In the first time the main goal of experimental chemisorption studies has been the solution of applied problems, they were based on directly measuring the rate of the absorption of gases by chemical absorbents. It was found in these studies that the mechanism of substance transfer close to the interphase boundary changed with time. The tracer method has been extensively used to study the rate of mass transfer in systems with chemical reactions. It allows us to indirectly determine whether or not the regime of mass transfer changes by recording changes in the mass transfer coefficient. The experimental data (Aksel'rod, 1987; Dilman et al., 1998) lead to conclude that an increase in the rate of mass transfer is caused by a change in the mechanism of transfer in the liquid phase. The mechanism then changes from diffusion to convective.

Much work has been done to study surface phenomena in chemisorption by optical methods. Optical methods allow processes that develop near the interphase boundary to be visualized. For instance, photographs of convective flows during the chemisorption of carbon dioxide by an aqueous solution of monoethanolamine (MEA) were obtained

by schlieren photography (Imaishi and Fujinawa, 1980). It was found that a "finger" structure of reaction product propagation in the liquid chemisorbent formed. In addition, it was noted that there was a delay between the moment when the reacting gas was brought in contact with the chemisorbent and the formation of such a flow structure.

Currently, we have a diversity of optical methods that can be applied to study interfacial phenomena. The corresponding equipment must, however, have high time and spatial resolution and strong magnification for these methods to be used successfully. For instance, several different optical methods were employed to visualize the absorption of carbon dioxide by various chemisorbents (Kutepov et al., 2001). It was, in particular, shown that so-called fingers observed were diffusion traces behind drops of a heavy reaction product that settled down in a lighter chemisorbent (Karlov et al., 2007).

Important data on the process were obtained by the laser probing of the interphase surface (Kutepov et al., 1997). A beam of laser light was directed onto the interphase boundary from above at an angle smaller than the total reflection angle. A fine-grain structure was observed in the cross section of the reflected beam in images taken 6-12 s after the beginning of the reaction. On a screen, this image resembled a light source observed through a glass frozen or misted over. This was evidence of the formation of some speckle structure that appeared in the liquid because of coherent light scattering by inhomogeneities of size on the order of the light wavelength. It was suggested that this was a manifestation of microscopic inhomogeneities at the interphase boundary related to the beginning of the development of interfacial instability.

Another important result of optical studies of chemisorption was obtained by polarization-interference microscopy. This was the work where unusual reaction product behavior on a brim meniscus of wetting was observed (Karlov et al., 2002). It was suggested that the meniscus was responsible for the large-scale convective motion of a liquid in chemisorption.

Very much attempts have been made to describe convection at the nonlinear stage of the development of perturbations and hence derive correlations for the rate of mass transfer under instability conditions. The equations obtained are overloaded by assumptions concerning the physical conditions of the process and contain a large number of parameters that are necessary to measure. These limitations prevent their use for a detailed description of the kinetics of chemisorption. It follows that the most promising approach to studying the fundamental laws of chemisorption is experimental methods that can be based on optical visualization.

## 2. Experimental

With the use of interference microscope we could visualized at a real time the evolution of interfacial phenomena on a spherical bubble of carbon dioxide formed on the end of microsyringe needle and mounted in the water solution of a base. This gave the possibility to describe in detail the principle stages of instability, to estimate its duration and to suggest a physical interpretation of the experimental pattern. Polarizing interference microscope is schematically represented in Fig. 1.

The illuminating part contained light source case 1 with incandescent lamp 2 inside. Thermal light filter 3 was used to absorb lamp infrared radiation and protect the other optical scheme elements from heating. Lens-collimator 4 generated a parallel light

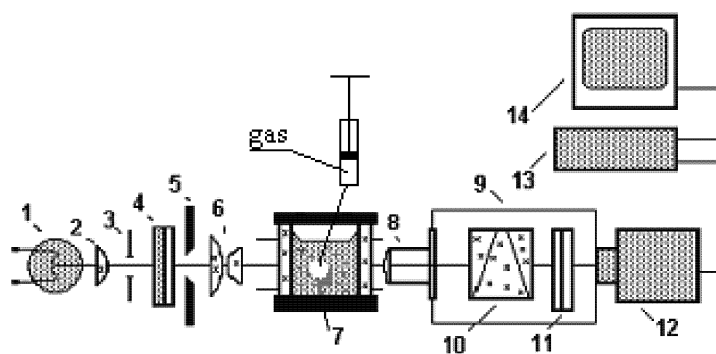

Fig. 1. Polarizing interference microscope: (1) filament lamp; (2) lens; (3) aperture; (4) polarizer; (5) slit-shaped aperture; (6) condenser; (7) cell; (8) microlens; (9) polarizing interference unit; (10) prism; (11) analyzer; (12) TV camera; (13) video type recorder, and (14) TV monitor

beam, which passed through polarizer 5 and illuminated the liquid volume under study in cell 6 equipped with pipe lines 7 and 8 for the introduction of gases and liquids. After passing the polarizer, the beam turned linearly polarized. Chemisorption-induced phase changes in the experimental cell were recorded by charge-coupled device (CCD) camera 12. Objective 9 formed an image of the experimental cell volume under study on the sensitive surface of the camera. Polarization prism 10 and analyzer 11 together with polarizer 5 were the elements of the polarization interferometer that formed the interference picture of changes in the refractive index field in the liquid volume studied. The optical scheme of the polarization-interference microscope gave a 10 to 40 magnification of inhomogeneities close to the interphase surface. A digitized image from the CCD camera was simultaneously recorded in real time in the form of fragments in computer memory 13 and in the form of a TV signal, by a videorecorder. This allowed us to perform computer processing of the most interesting and important image fragments on the one hand and repeatedly look through a video record of the process as a whole in real time using monitor 14, on the other.

When chemisorption process records are examined frame by frame, we observe changes with time in the interference picture near the interphase boundary. We can therefore determine the instants of the appearance of inhomogeneities of various types after the introduction of a carbon dioxide bubble into the cell. This allows us to measure all characteristic chemisorption times.

Chemisorption (the absorption of a gas by a liquid accompanied by a chemical reaction) was studied for very simple chemical systems. We selected carbon dioxide as an absorbate and aqueous solution of monoethanolamine (MEA) as chemisorbent. Such physicochemical systems are easy to handle, they are not toxic and at the same time are extensively used in chemical technology.

A cell for chemisorption 7 was a rectangular parallelepiped of height 40 mm, width 18 mm, and thickness 20 mm along the direction of light beams. Its design allowed the cell to be washed and chemisorbents changed without dismantling the experimental unit.

### 3. Visualization Of The Time Evolution Of Chemosorption

The observation of changes in the interference picture close to the interphase boundary between carbon dioxide and an aqueous solution of monoethanolamine in real time with magnification allows us to track the dynamics of formation and development of the diffusion and hydrodynamic surface layers during chemisorption and the appearance of convection. The images given below are evidence of a complex space-time character of the development of the interfacial process that cannot be observed by usual visual methods because of its small-scale character.

The appearance of the reaction product at the bubble surface is observed after some period which may last several seconds after the inert gas in bubble is substituted by carbon dioxide (Fig. 2a). Inhomogeneity takes the form of small drops formed at the interphase boundary. One can see the flows of the liquid heated due to of reaction. At this stage the reaction seems to proceed via the diffusion-kinetic mechanism. At the same time the movement of the liquid along the interface is detected. Such behavior is inherent in chemo-capillary instability which intensifies mass transfer at the interface.

Later on, the film of reaction product becomes more and more thick and starts to precipitate along the bubble surface to its bottom as if it is a separate quasi phase, possessing its own surface tension (Fig. 2b). This corresponds to the chemo-gravitational mechanism of instability.

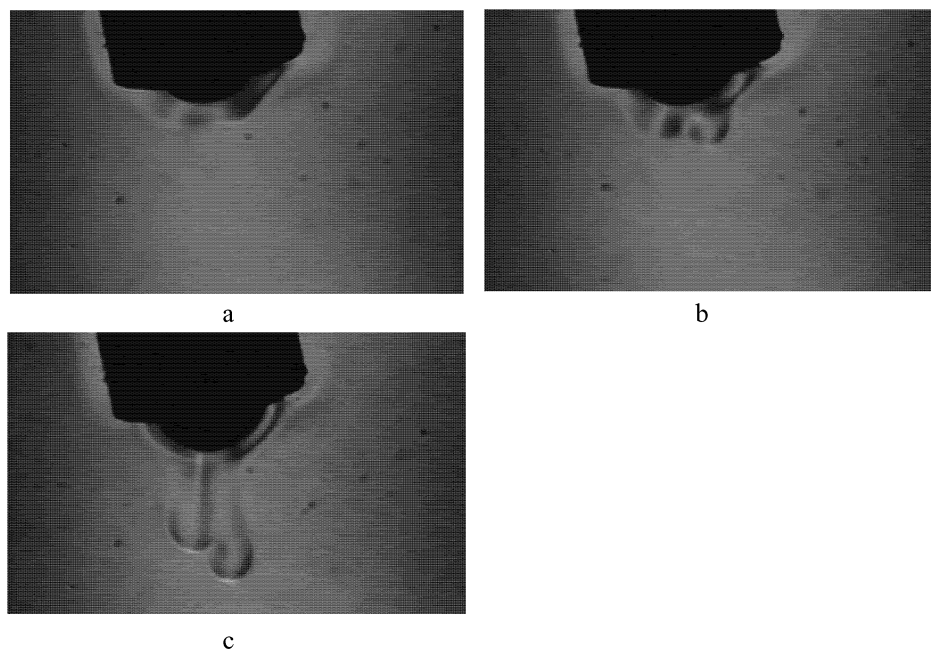

*Figure 2. Interference patterns corresponding: (a) to the moment of instability generation at the interface; (b) to the appearance of droplets; (c) to the movement of product droplets from the interface*

For monoethanolamine, surface perturbations that develop with time take the form of separate local drops. Some drops separate from the interphase surface and settle down onto the cell bottom, remaining unmixed with the surrounding liquid, as if reaction products are a separate phase with a surface tension. It was found experimentally that the time interval preceding the chemisorption stage under consideration primarily depends on the concentration of monoethanolamine in solution.

Subsequent stages of the chemisorption of carbon dioxide by aqueous solutions of monoethanolamine are shown in Fig. 2c. We observe the formation of a jet reaction product flow toward the bottom of the cell. The size of drops does not change.

The interferograms shown in the figures are evidence that the time-space evolution of chemisorption has several features common to all such processes. This leads us to suggest a time scenario of the development of chemisorption and characterize its main stages. The experimental data obtained for each stage can then be used to suggest a physicochemical explanation of the principal phenomena characteristic of the absorption of gases accompanied by chemical reactions.

#### 4. Time Scenario Of The Development Of Chemosorption

Let us consider successive chemisorption stages on the basis of the experimental data.

(1) After carbon dioxide is brought in contact with an aqueous solution of a chemisorbent, a diffusion boundary layer begins to form at the interphase boundary. Its formation is related to the accumulation of the reaction product, which is heavier than the surrounding liquid, in this layer. We almost do not observe carbon dioxide penetration into solutions of monoethanolamine because the chemical reaction is faster than the diffusion of the gas in the liquid. The rate of the process is limited by the rate of the mass transfer in the liquid phase close to the interphase surface. For this reason, the whole reaction-diffusion zone is localized inside a very thin undersurface layer.

(2) The thickness of the diffusion boundary layer increases as the heavier reaction product is accumulated near interphase surface. In some time, it attains its critical thickness and can lose stability by one of two mechanisms. The first mechanism is related to local surface tension gradients at the gas-liquid interface formed because of the nonuniform composition of the liquid phase (chemicapillary instability). This instability causes the appearance of small-scale convective motion close to the interphase boundary which decreases diffusion resistance to chemisorbent mass transfer from the bulk of the liquid phase to the boundary. Convection intensifies chemisorption and accelerates an increase in the thickness of the diffusion boundary layer. Monoethanolamine itself and the products of its reaction with carbon dioxide (including intermediate products) exhibit surface active properties.

Secondly, stability loss by the diffusion boundary layer can follow the Rayleigh-Taylor mechanism (chemogravitational instability). According to this mechanism, density stratification of liquids is unstable when a heavier liquid is situated above and a lighter liquid, below. Surface perturbations that develop with time acquire the form of separate drops, which grow gradually. As a result, the regime of convective chemisorbent transfer to the surface develops close to the interphase boundary, which intensifies the whole chemisorption process. It replaces the chemicapillary mechanism when the thickness of the boundary layer of the reaction product reaches some certain value.

The delay of the appearance of drop chemogravitational convection after carbon dioxide is brought in contact with a chemisorbent is explained by the accumulation of the heavy reaction product close to the interphase boundary. This accumulation must precede convection. The appearance of macroscopic changes in the liquid phase because of instability, however, also takes time even after a sufficient amount of the heavy product is accumulated and critical first- or second-type instability conditions are established.

(3) Next, the boundary layer formed by the heavy reaction product near the interphase boundary collapses into drops, which results in the formation of a finger structure of convective flows with time. In essence, fingers are diffusion traces left by reaction product drops, which settle down to the bottom of the cell under the action of gravity force and virtually do not mix with the surrounding liquid. As distinct from photographing with a large exposure, an interference microscope with a high spatial and time resolution allows the structure of such flows to be visualized.

The gravitational precipitation of drops causes the appearance of intense convective liquid mixing. As a result, diffusion deceleration of mass transfer disappears, and chemisorption is fully controlled by the rate of convective mass transfer. This is the working chemisorption regime that must be realized under industrial conditions.

### Acknowledgments

This work was supported by the Russian Foundation for Basic Research (projects 08-08-00530).

### References

- Aksel'rod Yu.V., 1987, Surface convection under mass transfer with chemical reaction. Abst. Intern. Seminar "Contemporary Problems of Heat and Mass Exchange in Chemical Engineering", ITMO im. A. V. Lykova, Minsk, 3, 148-155 (in Russian).
- Dil'man V.V., Kulov N.N., Lotkhov V.A., Kaminsky V.A. and Naidenov V.I., 1998, About difference absorption and desorption rate. *Theor. Found. Chem. Eng.* 32, 337-348.
- Frank-Kamenetskii D.A., 1987, Diffusion and Heat Transfer in Chemical Kinetics. Nauka, Moscow (in Russian).
- Imaishi N. and Fujinawa K., 1980, An optical study of interfacial turbulence accompanying chemical absorption. *Intern. Chem. Eng. J.* 20, 226-242.
- Karlov S.P., Kazenin D.A. and Vyazmin A.V., 2002, The time evolution of chemogravitational convection on a brim meniscus of wetting. *Phys. A.* 315, 236-240.
- Karlov S.P., Kazenin D.A., Baranov D.A., Volkov A.V., Polyanin D.A. and Vyazmin A.V., 2007, Interphase effects and macrokinetics of chemisorption in the absorption of CO<sub>2</sub> by aqueous solutions. *Rus. J. Phys. Chem. A.* 81, 665-679.
- Kutepov A.M., Kazenin D.A., Karlov S.P. and Vyazmin A.V., 1997, Same results laser spectroscopy interphase surface under chemisorption. *Proc. MSACE "Processes and Apparatus of Chemical Engineering"*. Moscow, 2, 3-12 (in Russian).
- Kutepov A.M., Pokusaev A.M., Kazenin D.A., Karlov S.P. and Vyazmin A.V., 2001, Experimental investigation interfacial mass transfer in gas-liquid system by optical methods. *Theor. Found. Chem. Eng.* 35, 213-218.